

TDBU

Electrical Service Requirements (ESR)

JULY 2004 ISSUE

(Published Quarterly)

**This manual and the information contained in it is for
Southern California Edison ("EDISON"), and Public use.**

► SCE Public ◀

"Copyright© 2004 by Southern California Edison Company.

All rights reserved. No part of this work covered by the copyrights hereon may be reproduced, copied, re-compiled or transmitted in any form or by any means - graphic, electronic or mechanical, including photocopying, recording, information storage and retrieval systems or otherwise - without the prior written permission of Southern California Edison Company."

This manual was published by TDBU Standards & Publications,
14005 South Benson Avenue, Chino, CA 91710-7026 using Adobe® FrameMaker.

Effective Date
7-30-2004

Electrical Service Requirements

Manual Summary July 2004 Issue

EFFECTIVE DATE: JULY 30, 2004

The following chapters/pages have been approved for publication and implementation on the effective date noted above. Some or all of the information may have been communicated previously to field personnel by other publications.

Overview

Various chapters/pages in the ESR Manual are revised to include minimum meter height requirements located in franchise areas, seal fitting requirements for hazardous locations, and administrative changes. The revised ESR Manual chapters/pages are listed below.

Chapter/Page Title	Page Number	Change	Type of Change
Title Page	—	Revised	Administrative
Table of Contents	—	Revised	Administrative
List of Figures	—	Revised	Administrative
ESR-1	1-28	Revised title and content of Section 15.3, "EYS Vertical Conduit Seal Fitting and Material Application." The previous standard ("End Seal Application") did not meet the listed materials required by the NEC for hazardous locations to mitigate vapors and gases, and was not acceptable by the County of Los Angeles, Chief Electrical Inspector. This revised standard meets the listed materials required by and complies with the NEC.	Technical
	1-28	Added New Section 15.4, "Service Cable Replacement." This new section clarifies the customer's responsibility should the service cable require replacement. The existing vertical seal fitting will be cut out (due to the sealing compound inside the vertical fitting) and the replacement seal fitting will be installed, both at the customer's expense.	
	1-29	Revised the title and illustration shown in Figure 1-4: EYS Vertical Conduit Seal. This revised figure shows the new EYS vertical seal installation corresponding to revised Section 15.3 requirements.	
ESR-3	3-8	Deleted last bullet item in Section 6.1, "Pole Riser (Conduit)". The option where the customer furnishes riser material at their expense no longer applies.	Technical
	3-12	Revised the maximum length of conduit in Section 13.4, "Maximum Length of Conduit", to be consistent with the requirements of DDS-3.	
	3-16	Added to Section 16.2, "Doors", the requirement for a doorstop mechanism to keep the door open.	
	3-19	Added to Section 16.10, "Meter Heights", an exception where the minimum meter height may be reduced to 3 feet provided the local ordinance dictates a maximum height for equipment located in franchise areas and the minimum meter height of 4 feet cannot be attained.	

Chapter/Page Title	Page Number	Change	Type of Change
ESR-5	5-6	Added to Section 5.0, "Metering Equipment Installation" , that the minimum meter height may be reduced to 3 feet for an exposed meter when a safety socket box with factory-installed test-bypass facilities is mounted and secured to the outside of the an enclosure or cabinet, all this provided the local ordinance dictates a maximum height for equipment located in franchise areas and the minimum meter height of 4 feet cannot be attained.	Administrative/ Technical
	5-20	Added Section 9.3, "Underground Service to Equipment Cabinets or Enclosures" , to include same information as in Section 5.0 plus that the maximum and minimum meter height are measured from the level standing and working surface area to the centerline of the meter socket.	
	5-39	Revised Figure 5-21 to more clearly identify the bare or green grounding conductor.	
Index	—	Revised	Administrative



Peter L. Hlapcich
 Manager of TDBU Operations & Engineering

For mailing list corrections, please send the correct information to:

TDBU Standards & Publications
 Chino Office Building
 14005 S. Benson Ave.
 Chino, CA 91710

or call (909) 548-7047 — PAX 15047.

**SOUTHERN CALIFORNIA EDISON
TDBU**

ELECTRICAL SERVICE REQUIREMENTS

TABLE OF CONTENTS

ESR-1	General Information	1-1
1.0	Scope and Purpose	1-3
2.0	Edison Office Locations, Phone Numbers & Community Index	1-3
3.0	Energy Management Programs	1-16
3.1	Residential	1-16
3.2	Commercial/Industrial/Agricultural	1-16
4.0	Dig Alert	1-16
5.0	Electric Vehicles	1-16
6.0	Voltage Standards	1-16
6.1	Standard Distribution Voltages	1-16
6.2	Customer Service Voltages	1-17
6.3	Customer Utilization Voltages	1-17
7.0	Customer Transformation and Harmonic Interference	1-18
7.1	High Voltage Service:	1-18
7.2	Low Voltage Service:	1-18
8.0	Agricultural Power Service Three-Phase 240 and 277/480 Volts	1-18
8.1	100 Amp Service	1-19
8.2	200 Amp Service	1-19
8.3	Above 200 Amp Service	1-19
9.0	Overhead Service	1-19
9.1	To Customer's Service and Meter Pole	1-19
9.2	To Customer's Building or Structure	1-20
10.0	Underground Service	1-20
10.1	To Customer's Service and Meter Post	1-20
10.2	To Customer's Building or Structure	1-20
11.0	Service or Meter Switch—General Requirements	1-20
12.0	Customer Generators	1-20
12.1	Rule 21 Net Generation Output (NGO) Metering	1-20

APPROVED <i>PhH</i>	Table of Contents	ESR
EFFECTIVE DATE 7-30-04	Electrical Service Requirements ▶ SCE Public ◀	PAGE TOC-i

13.0	Short-Circuit Current	1-23
13.1	10,000 Amps and Below	1-23
13.2	Greater than 10,000 Amps	1-23
13.3	Exceptional Cases	1-23
14.0	Electric-Magnetic Fields	1-23
14.1	Electric Fields.	1-23
14.2	Magnetic Fields.	1-24
14.3	Edison’s Corporate EMF Policy	1-24
14.4	Sources of Magnetic Fields	1-24
14.5	Magnetic Field Management Techniques	1-26
14.6	Summary	1-27
15.0	Residential Area Installations	1-27
15.1	Hazardous Areas by Class and Division	1-28
15.2	Location of Service Facilities	1-28
15.3	EYS Vertical Conduit Seal Fitting and Material Application	1-28
15.4	Service Cable Replacement	1-28
ESR-2	Overhead Service Connections 0-600 Volts	2-1
1.0	Overhead Service General Information.	2-4
2.0	Combination Loads	2-4
2.1	Single-Phase Service – 120/208, 120/240, 240, and 240/480 Volts.	2-4
2.2	Three-Phase Four-Wire Service	2-4
2.3	Three-Phase Four-Wire 120/208 Volt Wye Service	2-4
2.4	Three-Phase Four-Wire 277/480 Volt Wye Service	2-4
2.5	Three-Phase Four-Wire 120/240 Volt Delta Service.	2-4
2.6	Three-Phase Service—120/208, 240, and 277/480 Volts.	2-5
3.0	Service Drops	2-5
3.1	General.	2-5
3.2	Single Point of Service Delivery Per Building	2-5
3.3	Point of Service Delivery - Two or More Buildings on the Same Lot or Premises.	2-6
3.4	Number of Service Drops at One Point of Service Delivery	2-6
3.5	Maximum Length	2-6
3.6	Service Drop Termination on the Customer’s Structure	2-7
3.7	Height of Point of Service Drop Attachment on the Customer’s Structure.	2-7
4.0	Service Drop Supports.	2-7
4.1	General.	2-7
4.2	Wood Buildings.	2-8
4.3	Residential Buildings	2-8
4.4	Other Than Wood Buildings	2-8
4.5	Horizontal Timbers	2-8
4.6	Vertical Risers	2-8

ESR	Table of Contents	APPROVED 
PAGE TOC-ii	Electrical Service Requirements ▶ SCE Public ◀	EFFECTIVE DATE 7-30-04

5.0	Location of Service Drop Supports or Point of Building Attachment	2-9
5.1	General Requirements	2-9
5.2	Specific Requirements	2-10
5.3	Exceptions	2-10
6.0	Service Heads	2-11
6.1	General	2-11
6.2	Maximum Number of Service Heads - Parallel Service Entrances	2-11
6.3	Location of Service Head	2-11
6.4	Height of Service Heads	2-11
7.0	Service Entrance Conductors and Raceways	2-12
7.1	General	2-12
7.2	Service Entrance Conductors	2-12
7.3	Service Entrance Raceways	2-12
7.4	Service Entrance Cable	2-13
7.5	Swimming Pool Clearances	2-24
7.6	Minimum Allowable Clearances for Services Drops	2-25
8.0	Customer Owned Service and Meter Poles	2-26
8.1	General Requirements for Permanent and Temporary Service 0-600 Volts	2-26
8.2	Wood Brace for Temporary Service Requirements One Year or Less: Requirements in Figure 2-14 (page 2-30)	2-28
9.0	High Voltage Connections 2,400, 4,160, 4,800, 7,200, 12,000, 16,500 & 33,000 Volts .	2-33
9.1	General	2-33
9.2	Service	2-33
9.3	Single Phase Service Capacity	2-33
9.4	Three Phase Service Capacity	2-33
9.5	Single point of Service Delivery	2-34
9.6	Service Support – Customer’s Service Pole	2-34
ESR-3	Underground Service Connections 0-600 Volts	3-1
1.0	Underground Service Connections	3-5
2.0	Service Capacity 0-600 Volts	3-5
2.1	Single-Phase Service - 120/208, 120/240, 240, and 240/480 Volts	3-5
2.2	Three-Phase Service - 120/208, 240 and 277/480 Volts	3-5
3.0	Service Capacity 600 Volts and Above	3-6
3.1	Single-Phase Services	3-6
3.2	Three-Phase Services	3-6
4.0	Service Specifications	3-6
4.1	Easement	3-7
4.2	Bill of Sale	3-7
4.3	Permits	3-7

APPROVED 	Table of Contents	ESR
EFFECTIVE DATE 7-30-04	Electrical Service Requirements ▶ SCE Public ◀	PAGE TOC-iii

5.0	Temporary Service Connections	3-7
6.0	Underground Service From An Overhead Source	3-8
6.1	Pole Riser (Conduit)	3-8
6.2	Service Termination Facilities	3-8
6.3	Service Conductors	3-8
7.0	Company Owned Transformers Installed on Customer's Premises	3-9
8.0	Underground Service From an Underground Source	3-9
9.0	Single Point of Service Delivery Per Building	3-10
10.0	Single Point of Service Delivery for Each Premises.	3-10
11.0	Factory Built/Modular Homes	3-10
12.0	Location of Point of Service	3-10
12.1	Low voltage service (0-600 volts)	3-10
12.2	Service (above 600 volts).	3-11
13.0	Service Conduit Installations	3-11
13.1	Size and number of conduits.	3-11
13.2	Depth of Conduit	3-11
13.3	Route of Conduit	3-12
13.4	Maximum Length of Conduit.	3-12
13.5	Pull Rope or Muletape in Conduit	3-12
13.6	Bends in Conduit.	3-12
13.7	Inspection of Conduit	3-12
14.0	Service Conduit Entry Into Building Served.	3-13
14.1	Residential Buildings 0-600 Volts	3-13
14.2	Commercial Buildings 0-600 Volts.	3-13
14.3	Services 2,400-16,500 Volts	3-13
15.0	Terminating Enclosures	3-13
15.1	Type Required For Service 0-600 Volts	3-13
15.2	Type Required For Service Above 600 Volts	3-14
15.3	Subway Type Terminating Enclosures	3-14
15.4	Subway Type Terminating Pull Boxes	3-14
15.5	Wall Mounted Type Terminating Pull Boxes and Switchboard Pull Sections.	3-14
15.6	Access to and Working Space in Front of Termination Enclosures.	3-15

ESR	Table of Contents	APPROVED <i>PhH</i>
PAGE TOC-iv	Electrical Service Requirements ▶ SCE Public ◀	EFFECTIVE DATE 7-30-04

16.0	Electric Meter Rooms	3-15
16.1	Access	3-15
16.2	Doors	3-16
16.3	Foreign Equipment	3-16
16.4	Headroom	3-17
16.5	Illumination.	3-17
16.6	Meter Clearances	3-17
16.7	Meter Marking	3-19
16.8	Room Identification.	3-19
16.9	Vehicle Access.	3-19
16.10	Meter Heights.	3-19
16.11	Working Space - Metering and Service Equipment	3-19
16.12	Protective Barriers for Service Equipment.	3-22
ESR-4	Company Owned Transformers on Customer's Premises	4-1
1.0	General Information	4-2
2.0	Transformers on Pole Type Structures	4-2
3.0	Customer Provided Transformer Room or Vault	4-3
4.0	Outdoor Transformer Enclosures	4-4
4.1	Walled Transformer Enclosures	4-4
4.2	Fenced Transformer Enclosures	4-5
4.3	Padmounted Transformers	4-5
4.4	Subsurface Transformers.	4-6
4.5	Service Equipment.	4-6
4.6	Service Connections	4-6
4.7	Grounding	4-6
ESR-5	Meters – EXO Installations	5-1
1.0	Single and Three Phase Meters and Metering Equipment.	5-4
2.0	Meter Sockets.	5-4
3.0	Meter Switch	5-5
3.1	Number of Switches	5-6
3.2	Sequence	5-6
4.0	Main Service Disconnect - Multiple Metering	5-6
5.0	Metering Equipment Installations	5-6
6.0	Meter Locations	5-7
6.1	Meter Access	5-8
7.0	Residential Occupancies	5-11
7.1	Individually Metered 120/240 volt services	5-11
7.2	Individually Metered 120/208 volt three-wire services	5-12

APPROVED 	Table of Contents	ESR
EFFECTIVE DATE 7-30-04	Electrical Service Requirements ▶ SCE Public ◀	PAGE TOC-v

8.0	Commercial and Industrial Occupancies	5-12
8.1	Single Phase Service 120/240 Volt.	5-12
8.2	Three Phase Services 120/208 Volt, 240 Volt, 120/240 Volt and 277/480 Volt	5-12
8.3	Meter switch larger than 125 amperes on a 100 ampere safety socket box.	5-13
8.4	Meter Sockets – Self-Contained, Non-Residential	5-13
8.5	Agricultural Power Service.	5-14
9.0	Factory Wired Safety Socket Boxes	5-19
9.1	Overhead Service	5-19
9.2	Underground Service.	5-19
9.3	Underground Service to Equipment Cabinets or Enclosures	5-20
10.0	Current Transformer Cabinet & Meter Socket Panel	5-27
11.0	Grounding and Bonding	5-33
11.1	Electrical Service Grounding and Bonding Diagrams.	5-34
ESR-6	Switchboards 600 Volts and Below	6-1
1.0	Switchboards 600 Volts and Below	6-3
2.0	Grounding and Bonding	6-4
3.0	Instrument Transformer Compartments.	6-4
4.0	Meters and Meter Panels.	6-4
5.0	Totalized Services	6-5
6.0	Overhead Service Connections.	6-5
7.0	Underground Service Connections.	6-5
8.0	Moisture	6-5
9.0	Service Entrance Conductors	6-5
10.0	Termination Points	6-5
11.0	Switchboard Locations	6-6
ESR-7	Switchboards Above 600 Volts	7-1
1.0	General Information	7-4
2.0	Engineering Specifications.	7-4
3.0	Manufacturer’s Drawings for Approval	7-4
4.0	Service Cable Termination Section	7-5
5.0	Available Neutral Grounding Schemes	7-5
6.0	Working Space for High Voltage Switchboards	7-5
7.0	Utility Compartment Labeling	7-6
8.0	Safety Grounding Provisions	7-6
9.0	Meter Panel and Doors	7-6

ESR	Table of Contents	APPROVED <i>PhH</i>
PAGE TOC-vi	Electrical Service Requirements ▶ SCE Public ◀	EFFECTIVE DATE 7-30-04

10.0	BIL Rating	7-6
11.0	Ventilation Openings.	7-6
12.0	Door Access To Metering Cubicle(s).	7-7
13.0	Weatherproofing and Locking	7-7
14.0	C.T. and V.T. Installations	7-7
15.0	Bus Bars and Conductors.	7-7
15.1	Approved Bus Material	7-7
15.2	Bus Dimensions and Spacing	7-7
15.3	Bus Installation, for Current Transformers	7-7
15.4	Conductors Passing Through Compartment Walls	7-7
16.0	Metering Compartments, General	7-7
16.1	Insulated Neutral Termination	7-7
16.2	Instrument Transformer Mounting.	7-8
16.3	Voltage Transformers Mounting (Unistrut).	7-8
16.4	Current Transformers and Bus Link	7-8
16.5	Test Transformer Supports	7-8
16.6	Phase and Neutral Taps for Fuses and V.T.'s	7-8
16.7	Fuse Specifications	7-8
16.8	Voltage Transformer Disconnect Requirements	7-8
17.0	Sealing of Metering and Pull Sections	7-9
18.0	Service Connections of Switchboards.	7-9
18.1	Underground Service.	7-9
18.2	Underground Service Termination Pull Section	7-9
19.0	Service and Meter Switch	7-9
19.1	Location with Respect to Metering Equipment, Wiring and Devices	7-10
20.0	Switchboard Metering Section.	7-10
20.1	Neutral Conductor - 4,160 Volt Service	7-11
20.2	Handles on Hinged Panels.	7-11
20.3	Meter Panel Details.	7-11
20.4	Meter Clearances - Enclosed Meter Panels	7-11
20.5	Meter Sockets & Test Blocks	7-11
20.6	Meters	7-11
20.7	Test switches and Phasing Transformers	7-12
20.8	Meter locations Prohibited.	7-12
20.9	Barriers	7-12
ESR-8	Glossary	8-1
1.0	Glossary and Abbreviations	8-1
ESR-9	Alphabetical Index.	9-1

APPROVED 	Table of Contents	ESR
EFFECTIVE DATE 7-30-04	Electrical Service Requirements ▶ SCE Public ◀	PAGE TOC-vii

**SOUTHERN CALIFORNIA EDISON
TDBU**

ELECTRICAL SERVICE REQUIREMENTS

LIST OF TABLES

Table TOC-1	List of Edison Approved EUSERC Drawings	TOC-xiv
Table 1-1	Service Planning Office – Phone Numbers & Locations	1-4
Table 1-2	City/Service Planning Directory	1-6
Table 1-3	Customer Service Voltages	1-17
Table 1-4	Customer Utilization Voltages	1-17
Table 1-5	Short-Circuit Current	1-23
Table 1-6	Magnetic Fields From Electrical Appliances.	1-25
Table 2-1	Timber Risers	2-9
Table 2-2	Minimum Allowable Vertical Clearance Over Buildings and Structures 0-600 Volt Service Drops, Residential	2-25
Table 2-3	Minimum Service Cable Clearance Above Ground	2-25
Table 2-4	Vertical Clearances Above Railroads, Thoroughfares and Ground (G.O. 95 Table – 1)	2-26
Table 3-1	Conduit or Cable System Minimum Cover	3-12
Table 3-2	Meter Room–Meter Clearances	3-18
Table 3-3	Approved Riser Bend Materials and Sizes.	3-23
Table 3-4	Concrete Encasement Schedule.	3-24
Table 3-5	Edison Approved Service Conduit Material.	3-25
Table 3-6	Handhole, Pull Box and Manhole Application and Size	3-41
Table 3-7	Terminating Pull Section Minimum Dimensions	3-45
Table 4-1	Approved Methods of Transformer Installation	4-2
Table 4-2	Customer Provided Transformer Room Regulations	4-3
Table 4-3	Fenced Transformer Enclosures	4-5
Table 4-4	Padmounted Transformers—General Locations.	4-6
Table 5-1	Meter Location per Type of Occupancy	5-8
Table 5-2	Prohibited Meter Locations	5-10
Table 5-3	Self-Contained & Current Transformer Meter Socket Terminal Arrangements	5-15
Table 6-1	Minimum Pull Section Dimensions.	6-14
Table 6-2	Number of Service Conduits for Commercial/Industrial Underground Pull Sections	6-15

ESR	List of Tables	APPROVED <i>PhH</i>
PAGE TOC-viii	Electrical Service Requirements ▶ SCE Public ◀	EFFECTIVE DATE 7-30-2004

Table 6-3 Maximum Allowable Bus Size 6-25

Table 7-1 High Voltage Utility Metering Section Dimensions 7-14

Table 7-2 High Voltage Busway Service Head Dimensions 7-20

APPROVED 	List of Tables	ESR
EFFECTIVE DATE 7-30-2004	Electrical Service Requirements ▶ SCE Public ◀	PAGE TOC-ix

**SOUTHERN CALIFORNIA EDISON
TDBU**

ELECTRICAL SERVICE REQUIREMENTS

LIST OF FIGURES

Figure 1-1	Sources of Magnetic Fields	1-25
Figure 1-2	Meter Panel Locations	1-26
Figure 1-3	Magnetic Field Strength Measurements 1Ø PM Transformer	1-27
Figure 1-4	EYS Vertical Conduit Seal.	1-29
Figure 2-1	Overhead Service Connections on Commercial & Industrial Buildings	2-14
Figure 2-2	Overhead Service Connections on Residential Building	2-15
Figure 2-3	Methods of Attaching Service Drops to Buildings	2-16
Figure 2-4	Solid Wood Service Drop Attachment Risers.	2-17
Figure 2-5	Conduit Service Drop Attachment Risers (Periscope Type).	2-18
Figure 2-6	Service Drop Clearance – Residential Premises	2-19
Figure 2-7	Clearance of 0-600 Volt Services from Doors, Exits, Windows, Fire Escapes	2-20
Figure 2-8	Minimum Vertical Clearance of Service Drops—Industrial or Commercial.	2-21
Figure 2-9	Service Drop Clearance – Commercial or Industrial Premises	2-22
Figure 2-10	Clearance of Timber Risers on Buildings	2-23
Figure 2-11	Swimming Pool Clearances	2-24
Figure 2-12	Pitch of Roof	2-25
Figure 2-13	Temporary Service Requirements (Service for One Year or Less).	2-29
Figure 2-14	Wood Brace for Temporary Service Requirements (Service for One year or Less).	2-30
Figure 2-15	Customer Owned Permanent or Temporary Service Pole	2-31
Figure 2-16	Optional Customer Owned Service and Meter Pole	2-32
Figure 2-17	Busway Service Head Requirements 3Ø 4-Wire Wye or Delta, 600V Maximum	2-35
Figure 3-1	Meter Room Clearances.	3-18
Figure 3-2	Working Space and Clearance Requirements 0-600 Volts	3-21
Figure 3-3	Protective Barrier for Service Equipment Installation Requirements	3-22
Figure 3-4	Typical Riser At Pole – Various Voltages.	3-23
Figure 3-5	Customer Conduit Installation and Typical Concrete Conduit Encasement	3-24
Figure 3-6	Underground Combination Meter Panel 0-600 Volts	3-25
Figure 3-7	Meter Panel for Single-Family Residential Underground Service, 300/400 Ampere (Class 320), 120/240 Volt Single Phase 3-Wire	3-26

ESR	List of Figures	APPROVED <i>PhH</i>
PAGE TOC-x	Electrical Service Requirements ▶ SCE Public ◀	EFFECTIVE DATE 7-30-2004

Figure 3-8 Underground Service Terminating Facilities for Residential Multiple Occupancy Service — 6 Meters Single Phase 3-Wire, 0-600 Amps, 0-600 Volts. 3-27

Figure 3-9 Underground Pull Box Equipped with Cable Terminations for Commercial or Residential use 0-600 Volts, 0-1,200 Amps 3-29

Figure 3-10 Combination Disconnecting Device and Terminating Enclosure 0-600 Volts, 1,200 Amperes Maximum 3-30

Figure 3-11 Underground Pull Boxes 3-31

Figure 3-12 Typical Service Lateral Installation for Single Family Residence 3-32

Figure 3-13 Typical Service Conversion From Overhead to Underground 3-33

Figure 3-14 Myers Plug-In-Type Meter Adapter 3-34

Figure 3-15 Plug-In Temporary (Piggy Back) Service Adapter 3-34

Figure 3-16 Temporary Service From A Padmount Transformer. 3-35

Figure 3-17 Temporary Service From Secondary Hand Hole, Pull Box or Pedestal. 3-36

Figure 3-18 Riser Bend for Multi-Family Residential Service Entrance, and (Recessed Service Applications) 3-37

Figure 3-19 Service Entrance for Single Family Dwelling Service 3-38

Figure 3-20 Exposed Service Conduit Installation 3-39

Figure 3-21 Riser Bend Installation at Wall or Pad. 3-40

Figure 3-22 Handholes, Pull Boxes and Manholes 3-41

Figure 3-23 Typical Mobile Home or Residential Service and Meter Post Maximum 200 Amps 120/240 Volts 3-42

Figure 3-24 Typical Underground Layout for Mobile Homes 3-44

Figure 3-25 Non-Residential Service Pedestals 0-200 Amperes, 0-600 Volts 3-45

Figure 3-26 Non-Residential Un-Metered Service Pedestal 0-200 Amperes, 0-240 Volts, Single Phase, LS-2, Street Lighting Systems Only 3-47

Figure 5-1 Typical Plaque/Directory Specifications. 5-5

Figure 5-2 Meter Socket – Terminal Arrangements. 5-15

Figure 5-3 Separation of Meter Assemblies For Electric and Gas Services. 5-16

Figure 5-4 Workspace 5-17

Figure 5-5 Meter Clearances 0-600 Volts. 5-17

Figure 5-6 Meter Switches and Main Disconnects. 5-18

Figure 5-7 Safety Socket Box with Factory-Installed Test-Bypass Facilities 100 Amp 5-20

Figure 5-8 Safety-Socket Box with Factory-Installed Test-Bypass Facilities 200 Amp 5-22

Figure 5-9 Test-Bypass/Disconnect Block for Safety Sockets 100 and 200 Amp 0-600 Volts . . 5-24

Figure 5-10 Test-Bypass/Disconnect Block for Safety Sockets 100 and 200 Amperes, 0-600 Volts (Bussed and/or Cable Terminations) 5-25

Figure 5-11 Safety Socket Box for Meters Used with Instrument Transformers 5-26

Figure 5-12 Combination Current-Transformer Cabinet and Meter Socket Panel for Overhead Service 400 Amperes Maximum 5-28

APPROVED 	List of Figures	ESR
EFFECTIVE DATE 7-30-2004	Electrical Service Requirements ▶ SCE Public ◀	PAGE TOC-xi

Figure 5-13	Combination Current-Transformer Cabinet and Meter Socket Panel for Underground Service 400 Amperes Maximum	5-29
Figure 5-14	Current-Transformer Mounting Base Three-Phase, Four-Wire Services 0-600 Volts, 400 Ampere Maximum	5-30
Figure 5-15	Current-Transformer Mounting Base Single or Three-Phase, Three-Wire Services 0-600 Volts, 400 Ampere Maximum	5-31
Figure 5-16	Single-Phase and Three-Phase Meters and Metering Equipment EXO Current Transformer Installation Meter Spacing and Clearances	5-32
Figure 5-17	Combination Meter and Service Section for Overhead Dwelling Service	5-35
Figure 5-18	Meter Remote From Service Section for Overhead Dwelling Service	5-36
Figure 5-19	Meter and Service with Current Transformer Enclosure Overhead Supply	5-37
Figure 5-20	Single-Meter Commercial Service with a Neutral (Where a Main Disconnecting Means is Required)	5-38
Figure 5-21	Three-Phase, Three-Wire Delta Service with Added Grounding Connector.	5-39
Figure 5-22	Commercial Service, Overhead Supply — Six Subdivisions or Less	5-40
Figure 5-23	Commercial Service, Overhead Supply More Than — Six Subdivisions of Service . . .	5-41
Figure 5-24	Combination Meter and Service For Underground Dwelling Service	5-42
Figure 5-25	Combination Meter and Service For Underground Multi-Family Dwelling Service — Six Subdivisions of Service or Less.	5-43
Figure 5-26	Combination Meter and Service for Underground Multi-Family Dwelling Service — More Than Six Subdivisions	5-44
Figure 5-27	Combination Meter and Service for Underground Commercial Service — Six Subdivisions or Less.	5-45
Figure 5-28	Combination Meter and Service for Underground Commercial Service — More Than Six Subdivisions of Service.	5-46
Figure 5-29	Switchboard Service Section	5-47
Figure 5-30	Underground Service Post	5-48
Figure 5-31	Concrete-Encased Electrode (UFER Ground)	5-49
Figure 5-32	Typical Single Phase Customer's Transformer Bonding and Grounding	5-50
Figure 5-33	Typical Three Phase Four Wire Wye, Customer's Transformer Bonding and Grounding.	5-51
Figure 5-34	Typical Three Phase Four Wire Delta, Customer's Transformer Bonding and Grounding.	5-52
Figure 5-35	High-Impedance Grounded Neutral System (NEC Section 250-36).	5-53
Figure 6-1	Standard Switchboard Service Section with Instrument-Transformer Compartment 0-600 Volts	6-7
Figure 6-2	Standard Switchboard Service Section with Instrument-Transformer Compartment and Filler Panel 0-600 Volts	6-8
Figure 6-3	Combination Switchboard Service Section and Pull Section 0-600 Volts, 2000 Amperes Maximum	6-9
Figure 6-4	Outdoor or Rain tight enclosures for Switchboards 0-600 Volts.	6-10

ESR	List of Figures	APPROVED <i>PhH</i>
PAGE TOC-xii	Electrical Service Requirements ▶ SCE Public ◀	EFFECTIVE DATE 7-30-2004

Figure 6-5 Overhead Service Termination Standard Switchboard Service Section 0-600 Volts . 6-11

Figure 6-6 Underground Service Terminating Facilities in Pull Boxes or Pull Sections,
0-600 Volts 6-12

Figure 6-7 Underground Service Termination Standard Switchboard Service Section
400 to 4000 Amp, 0-600 Volts. 6-14

Figure 6-8 Instrument-Transformer Compartment for Switchboards 0-1,000 Amps Maximum,
0-600 Volts Single- or Three- Phase Three-Wire 6-16

Figure 6-9 Instrument-Transformer Compartment for Switchboards 0-1000 Amperes,
0-600 Volts Three Phase Four-Wire 6-18

Figure 6-10 Instrument-Transformer Compartment for Switchboards 1001-3000 Amperes,
0-600 Volts Three Phase Four-Wire 6-20

Figure 6-11 Removable Link and Current-Transformer Support for Instrument-Transformer
Compartments with 4-inch Bus 0-600 Volts. 6-22

Figure 6-12 15-Inch Hinged Meter Panel 0-600 Volts 6-23

Figure 6-13 Instrument-Transformer Compartment for Switchboards 3001-4000 Amperes,
0-600 Volts Three Phase Four-Wire 6-25

Figure 6-14 Removable Link and Current-Transformer Support for Instrument-Transformer
Compartments with 5-inch Bus 0-600 Volts. 6-27

Figure 6-15 Self-Contained Meters Installed in Switchboards 0-200 Amps 0-600 Volts. 6-28

Figure 6-16 Clearances for Residential Multiple Metering Installations. 6-30

Figure 6-17 30-Inch Hinged Dual Socket Meter Panel 0-600 Volts. 6-32

Figure 7-1 High Voltage Metering Enclosure 2,400 to 16,500 Volt Service 7-13

Figure 7-2 High Voltage Switchboard 2,400 to 16,500 Volt Service 7-15

Figure 7-3 Mounting Pattern for Voltage & Current Transformers
2,400 - 16,500 Volt Service. 7-16

Figure 7-4 Indoor Current Transformer Dimensions for Metering Purposes 5 kV through 15 kV 7-17

Figure 7-5 Voltage Transformer (VT) Dimensions 5,000 through 15,000 Volt Outdoor 7-18

Figure 7-6 Underground Service Termination Pull Section 2,400 to 16,500 Volts 3 and 4 Wire 7-19

Figure 7-7 Busway Service Head - 601 to 34,500 Volts 3Ø 3 or 4W 7-20

Figure 7-8 High Voltage Meter Panel Detail - kWh Meter. 7-21

Figure 7-9 High Voltage Meter Panel Detail - kWh Meter and Control Power Meter. 7-22

Figure 7-10 High Voltage Meter Panel Detail - kWh Meter,
Control Power Meter and Reactive Meter. 7-23

Figure 7-11 Test Switch Layout and Removable Plate Details. 7-24

Figure 7-12 Control Power Meter Socket-Test Block Wiring Diagram 7-24

Figure 7-13 High-Voltage Switchboards Barrier For Metering Located in Front of C.T. Area . . . 7-25

APPROVED 	List of Figures	ESR
EFFECTIVE DATE 7-30-2004	Electrical Service Requirements ▶ SCE Public ◀	PAGE TOC-xiii

**SOUTHERN CALIFORNIA EDISON
TDBU**

ELECTRICAL SERVICE REQUIREMENTS

EUSERC DRAWINGS, REFERENCE AND APPROVALS

Table TOC-1: List of Edison Approved EUSERC Drawings

EUSERC #	EUSERC Page Acceptability ^(a)	Edison Page No.	EUSERC #	EUSERC Page Acceptability ^(a)	Edison Page No.	EUSERC #	EUSERC Page Acceptability ^(a)	Edison Page No.
301	A	3-25	326	A	6-8	348	A	6-11
301A	U		327	A	6-9	349	A	2-35
302	U		328	B		350	B	
302A	A	3-26	328A	A	5-31	351	NA	
303	NA		328B	U		352	B	
304	A	5-20	329	B		353	A	6-30
305	A	5-22	329A	A	5-30	354	A	6-10
306	A	6-28	329B	U		401	U	
307	A	3-42	330	A	6-22	402	U	
308	A	3-45	331	A	6-27	403	U	
309	NA		332	A	6-23	404	U	
310	NA		333	A	6-32	405	U	
311	A	5-24	334	B		406	U	
312	A	5-25	335	B		407	A	7-13
313	A	5-28	336	NA		408	A	7-16
314	A	5-29	337	B		409	NA	
315	A	3-30	338	NA		410	NA	
316	NA		339	A	5-26	411	B	
317	NA		340	B		412	U	
318	NA		341	B		413	U	
319	C	6-16	342	A	3-27	413A	U	
320	A	6-18	343	A	3-29	414	A	7-17
321	NA		343A	U		415	B	
322	A	6-20	344	A	3-31	416	A	7-18
323	NA		345	A	6-14	417	A	7-19
324	A	6-25	346	U		418	A	7-20
325	A	6-7	347	A	6-12			

(a) A = Acceptable, NA = Not Applicable, U = Unacceptable, C = Consult Edison, B = Intentionally Blank (Not Used).

ESR	EUSERC Drawings, Reference and Approvals	APPROVED <i>PhH</i>
PAGE TOC-xiv	Electrical Service Requirements ▶ SCE Public ◀	EFFECTIVE DATE 7-30-2004

ESR-1

GENERAL INFORMATION



TDBU
▶ **SCE Public** ◀



**SOUTHERN CALIFORNIA EDISON
TDBU**

ESR-1: General Information

TABLE OF CONTENTS

Section No.	Title	Page
1.0	Scope and Purpose	1-3
2.0	Edison Office Locations, Phone Numbers & Community Index	1-3
3.0	Energy Management Programs	1-16
3.1	Residential	1-16
3.2	Commercial/Industrial/Agricultural	1-16
4.0	Dig Alert	1-16
5.0	Electric Vehicles	1-16
6.0	Voltage Standards	1-16
6.1	Standard Distribution Voltages	1-16
6.2	Customer Service Voltages	1-17
6.3	Customer Utilization Voltages	1-17
7.0	Customer Transformation and Harmonic Interference	1-18
7.1	High Voltage Service:	1-18
7.2	Low Voltage Service:	1-18
8.0	Agricultural Power Service Three-Phase 240 and 277/480 Volts	1-18
8.1	100 Amp Service	1-19
8.2	200 Amp Service	1-19
8.3	Above 200 Amp Service	1-19
9.0	Overhead Service	1-19
9.1	To Customer's Service and Meter Pole	1-19
9.2	To Customer's Building or Structure	1-20
10.0	Underground Service	1-20
10.1	To Customer's Service and Meter Post	1-20
10.2	To Customer's Building or Structure	1-20
11.0	Service or Meter Switch—General Requirements	1-20
12.0	Customer Generators	1-20
12.1	Rule 21 Net Generation Output (NGO) Metering	1-20

REFERENCE NO. <i>PhH</i>	General Information	ESR-1
EFFECTIVE DATE 7-30-2004	Electrical Service Requirements ▶ SCE Public ◀	PAGE 1-1

TABLE OF CONTENTS

Section No.	Title	Page
13.0	Short-Circuit Current	1-23
13.1	10,000 Amps and Below	1-23
13.2	Greater than 10,000 Amps	1-23
13.3	Exceptional Cases	1-23
14.0	Electric-Magnetic Fields	1-23
14.1	Electric Fields	1-23
14.2	Magnetic Fields	1-24
14.3	Edison's Corporate EMF Policy	1-24
14.4	Sources of Magnetic Fields	1-24
14.5	Magnetic Field Management Techniques	1-26
14.6	Summary	1-27
15.0	Residential Area Installations	1-27
15.1	Hazardous Areas by Class and Division	1-28
15.2	Location of Service Facilities	1-28
15.3	EYS Vertical Conduit Seal Fitting and Material Application	1-28

LIST OF TABLES

Table No.	Title	Page
1-1	Service Planning Office – Phone Numbers & Locations	1-4
1-2	City/Service Planning Directory	1-6
1-3	Customer Service Voltages	1-17
1-4	Customer Utilization Voltages	1-17
1-5	Short-Circuit Current	1-23
1-6	Magnetic Fields From Electrical Appliances	1-25

LIST OF FIGURES

Figure No.	Title	Page
1-1	Sources of Magnetic Fields	1-25
1-2	Meter Panel Locations	1-26
1-3	Magnetic Field Strength Measurements 1Ø PM Transformer	1-27
1-4	EYS Vertical Conduit Seal	1-29

ESR-1	General Information	REFERENCE NO. <i>PhH</i>
PAGE 1-2	Electrical Service Requirements ▶ SCE Public ◀	EFFECTIVE DATE 7-30-2004

1.0 Scope and Purpose

The Electrical Service Requirements presented herewith provide detailed amplifications of certain established rules of the Southern California Edison, *An Edison International* Company, (hereinafter referred to as the Company) pertaining to electrical service connections, together with customers' installations of service wiring and service equipment. These requirements are issued for the guidance and assistance of electrical contractors, engineers, architects, and manufacturers engaged in the installation and design of electrical service wiring and service equipment. As an additional convenience, certain extracts from General Order No. 95, Rules for Overhead Line Construction; General Order No. 128, Rules for Construction of Underground Electric Supply and Communications Systems, of the Public Utilities Commission concerning service installations have been included for your reference.

The provision of these Electrical Service Requirements are intended to be in accordance with the Rules for Overhead Line Construction and the Rules for Construction of Underground Electric Supply and Communications Systems, of the Public Utilities Commission of the State of California, Titles 8 and 24 of the State of California, the National Electrical Code, and with all applicable local laws or ordinances, where any of such rules, orders, codes, laws, or ordinances have jurisdiction; but are not intended to be a substitute for any of such regulations.

In localities where no local ordinance is in force and where no provision is made for inspection by local or other authorities, the Company shall determine if a service wiring installation has been made in a safe and workman like manner before making a service connection to such installation.

For the purpose of these requirements, the customer or any other person, firm, or corporation making a service wiring installation will be considered the electrical contractor.

Any unusual situation not specifically covered in these Electrical Service Requirements, should be referred to the Company local service center, in the area where the service is supplied. Telephone numbers for Company offices may be found in [Table 1-1 \(page 1-4\)](#).

2.0 Edison Office Locations, Phone Numbers & Community Index

Southern California Edison has an extensive network of Customer Service offices and telephone information numbers to serve builders, developers, and electrical contractors. [Table 1-1 \(page 1-4\)](#) is an alphabetical list of Edison Service Centers with address and phone numbers. [Table 1-2, "City/Service Planning Directory," on page 1-6](#) is an alphabetical list of cities and communities served by Edison and indicates the Edison Service Center responsible for its service. Use this table to identify the Edison Service Center serving the geographic location for which you need assistance. The corresponding telephone number for the Service Center can be found in [Table 1-1 \(page 1-4\)](#). Call this number when information is needed for new construction, relocation of metering facilities, overhead or underground wiring, temporary power poles, or any question or request that may require a technical response regarding these subjects. When calling these locations please ask for the Service Planner for your specific project location.

If you need additional information or technical assistance relating to these requirements, contact Gary Gonzales at (909) 548-7038 or email gary.gonzales@sce.com. For administrative inquiries, such as new manuals, revisions, etc., call (909) 548-7042 or FAX (909) 548-7051. In addition, you may address your technical questions to the attention of Gary Gonzales at:

TDBU
Construction Methods and Support Services
14005 S. Benson Ave.
Chino, CA 91710-7026

REFERENCE NO. 	General Information	ESR-1
EFFECTIVE DATE 7-30-2004	Electrical Service Requirements ▶ SCE Public ◀	PAGE 1-3

The *General Service* number (800) 655-4555 is provided for establishing electrical service in a customer's name, meter reading and billing questions, requests for discontinuing service, information regarding delinquent accounts, and questions of a general nature. Information is also available at our website: <http://www.sce.com/>.

Table 1–1: Service Planning Office – Phone Numbers & Locations (Column 1 of 2)

Service Center	Location	Telephone/ FAX Number
Antelope Valley	42060 10th Street West, Lancaster; CA 93534-4349	(661) 726-5617 FAX (661) 726-5680
Arrowhead	26364 Pine Avenue, Rimforest; CA 92378	(909) 337-2564 FAX (909) 337-8853
Barstow	30553 Rimrock Road, Barstow; CA 92311	(760) 252-6416 FAX (760) 252-6406
Bishop	374 Lagoon Street, Bishop; CA 93514	(760) 873-2913 FAX (760) 873-2921
Blythe	505 West 14th Avenue, Blythe; CA 92225	(760) 922-9158 FAX (760) 922-0662
Catalina Island	2800 East Willow Street, Long Beach; CA 90806	(562) 981-8237 FAX (562) 981-8289
Compton	P.O. Box 4699, Compton; CA 90224 1924 Cashdan Street, Compton; CA 90224	(310) 608-5023 FAX (310) 608-5174
Covina	800 West Cienega, San Dimas; CA 91773	(909) 592-3709 FAX (909) 592-3727
Foothill	7951 Redwood Avenue, Fontana; CA 92336	(909) 357-6191 FAX (909) 357-6185
Fullerton	1851 West Valencia Drive, Fullerton; CA 92833	(714) 870-3225 FAX (714) 870-3284
Huntington Beach	7333 Bolsa Avenue, Westminster; CA 92683	(714) 895-0244 FAX (714) 895-0188
Kernville	120 Woodlan Dr., Wofford Heights; CA 93285	(760) 376-2235 FAX (760) 376-4973
Long Beach	2800 East Willow Street, Long Beach; CA 90806	(562) 981-8237 FAX (562) 981-8289
Mammoth	P.O. Box 7329 3001 Chateau Road, Mammoth Lakes; CA 93546	(760) 934-8236 FAX (760) 934-5716
Monrovia	1440 South California Street, Monrovia; CA 91016	(626) 303-8489 FAX (626) 303-8452
Montebello	1000 Potrero Grande Drive, Monterey Park; CA 91755	(323) 720-5220 FAX (323) 720-5252
Ontario	1351 East Francis Street, Ontario; CA 91761	(909) 930-8591 FAX (909) 930-8438
Palm Springs	36100 Cathedral Canyon Drive, Cathedral City; CA 92234	(760) 202-4286 FAX (760) 202-4294
Redlands	287 Tennessee Street, Redlands; CA 92373	(909) 307-6791 FAX (909) 307-6772
ESR–1	General Information	REFERENCE NO. <i>PHH</i>
PAGE 1–4	Electrical Service Requirements ▶ SCE Public ◀	EFFECTIVE DATE 7-30-2004

Table 1-1: Service Planning Office – Phone Numbers & Locations (Column 2 of 2)

Service Center	Location	Telephone/ FAX Number
Ridgecrest	510 South China Lake Boulevard, Ridgecrest; CA 93555	(760) 375-1552 FAX (760) 375-1554
Saddleback	14155 Bake Parkway, Irvine; CA 92618	(949) 458-4416 FAX (949) 458-4472
San Jacinto Valley	26100 Menifee Road, Menifee; CA 92585	(909) 928-8290 FAX (909) 928-8377
San Joaquin Valley	P.O. Box 900, Tulare; CA 93275 2425 South Blackstone Avenue, Tulare; CA 93274	(800) 634-9174 FAX (209) 685-3287
Santa Ana	1241 South Grand Avenue, Santa Ana; CA 92705	(714) 973-5653 FAX (714) 973-5589
Santa Barbara	333 Love Place, Goleta; CA 93117	(805) 683-5211 FAX (805) 683-5293
Santa Monica	1721 22nd Street, Santa Monica; CA 90404	(310) 315-3291 FAX (310) 315-3270
Shaver Lake	P.O. Box 29, Shaver Lake; CA 93664 41694 Dinkey Creek Road, Shaver Lake; CA 93664	(559) 841-3191 FAX (559) 841-3178
South Bay	505 Maple Avenue, Torrance; CA 90503 P.O. Box 2944, Torrance; CA 90509-2944	(310) 783-9344 FAX (310) 783-9323
Tehachapi	421 West "J" Street, Tehachapi; CA 93561	(661) 823-2504 FAX (661) 823-2511
Thousand Oaks	3589 Foothill Drive, Thousand Oaks; CA 91361	(805) 494-7040 FAX (805) 494-7008
Valencia	25625 West Rye Canyon Road, Valencia; CA 91355	(661) 257-8255 FAX (661) 257-8259
Ventura	10060 Telegraph Road, Ventura; CA 93004	(805) 654-7444 FAX (805) 654-7323
Victorville	12353 Hesperia Road, Victorville; CA 92392	(760) 951-3219 FAX (760) 951-3159
Whittier	9901 Geary Avenue, Santa Fe Springs; CA 90670	(562) 903-3123 FAX (562) 903-3134
Yucca Valley	6999 Old Woman Springs Road, Yucca Valley; CA 92284	(760) 369-5412 ^(a) (760) 369-5413 ^(a) FAX (760) 369-5409

(a) Two telephone numbers.

REFERENCE NO. <i>PHH</i>	General Information	ESR-1
EFFECTIVE DATE 7-30-2004	Electrical Service Requirements ▶ SCE Public ◀	PAGE 1-5

Table 1–2: City/Service Planning Directory
(Column 1 of 19)

City	Service Center
Acton	Antelope Valley
Acton	Valencia
Adelanto	Victorville
Aerial Acres	Ridgecrest
Agoura	Thousand Oaks
Agoura Hills	Thousand Oaks
Agua Dulce	Valencia
Agua Fria	Arrowhead
Aguanga	San Jacinto Valley
Alberhill	San Jacinto Valley
Alessandro	San Jacinto Valley
Alhambra	Montebello
Alpine Forest	Antelope Valley
Alpine Glen	Arrowhead
Alpine Village	San Joaquin Valley
Alta Loma	Foothill
Alta Loma	Ontario
Altadena	Monrovia
Amberton	Ventura
Amboy	Yucca Valley
Anaheim	Fullerton
Anaheim	Santa Ana
Angelus Oaks	Redlands
Antelope Acres	Antelope Valley
Anza	San Jacinto Valley
Apple Valley	Victorville
Arcadia	Monrovia
Argus	Ridgecrest
Arlington	Ontario
Armona	San Joaquin Valley
Arnold Heights	San Jacinto Valley
Arrowbear Lake	Arrowhead
Arrowhead Highlands	Arrowhead
Arrowhead View	Arrowhead
Artesia	Long Beach
Ash Mountain	San Joaquin Valley
Atolia	Ridgecrest
Atwood	Fullerton
Auberry	Shaver Lake
Avalon	Catalina
Azusa	Covina
Azusa	Monrovia
Bagdad	Yucca Valley
Baker	Barstow

Table 1–2: City/Service Planning Directory
(Column 2 of 19)

City	Service Center
Bakersfield	San Joaquin Valley
Balance Rock	Kernville
Balboa	Huntington Beach
Balboa Island	Huntington Beach
Baldwin Hills	South Bay
Baldwin Hills	Santa Monica
Baldwin Park	Monrovia
Banning	Redlands
Banning	Palm Springs
Banning	San Jacinto Valley
Bardsdale	Ventura
Barstow	Barstow
Barton Flats	Redlands
Bassett	Covina
Bear Valley Springs	Antelope Valley
Beaumont	Redlands
Bell	Compton
Bell Canyon	Thousand Oaks
Bell Gardens	Compton
Bellflower	Compton
Belltown	Foothill
Belmont Shore	Long Beach
Belvedere	Montebello
Benton	Bishop
Beverly Hills	Santa Monica
Big Bear Lake	Redlands
Big Bear Lake	Victorville
Big Creek	Shaver Lake
Big Pine	Bishop
Big Pines Playground	Victorville
Big Tujunga Canyon	Monrovia
Bishop	Bishop
Bishop Creek	Bishop
Bixby Knolls	Long Beach
Bloomington	Foothill
Blue Cut	Foothill
Blue Jay	Arrowhead
Blythe	Blythe
Bodfish	Kernville
Bodie	Bishop
Boron	Ridgecrest
Bouquet Canyon	Valencia
Box Canyon	Thousand Oaks
Bradbury	Monrovia

ESR-1	General Information	REFERENCE NO. <i>PHH</i>
PAGE 1-6	Electrical Service Requirements ▶ SCE Public ◀	EFFECTIVE DATE 7-30-2004

Table 1–2: City/Service Planning Directory
(Column 3 of 19)

City	Service Center
Brea	Fullerton
Bridgeport	Mammoth
Bryman	Victorville
Bryn Mawr	Redlands
Buena Park	Fullerton
Burnt Mill Canyon	Arrowhead
Burnt Mill Heights	Arrowhead
Burtons Camp	Antelope Valley
Cabazon	Palm Springs
Cadiz	Yucca Valley
Cadiz Summit	Yucca Valley
Cajon	Foothill
Calabasas	Thousand Oaks
Calico	Barstow
Caliente	Antelope Valley
Caliente	Kernville
California City	Ridgecrest
California Hot Springs	Kernville
California Hot Springs	San Joaquin Valley
Calimesa	Redlands
Camarillo	Thousand Oaks
Camarillo	Ventura
Camarillo Heights	Ventura
Camp Angelus	Redlands
Camp Nelson	San Joaquin Valley
Camp Sabrina	Bishop
Canoga Park	Thousand Oaks
Cantil	Ridgecrest
Canyon Country	Valencia
Canyon Lake	San Jacinto Valley
Carbon Canyon	North Orange Country
Carbon Canyon	Ontario
Carpinteria	Santa Barbara
Carson	Compton
Casa Diablo Hot Springs	Bishop
Casitas Springs	Ventura
Castaic	Valencia
Catalina	Long Beach
Cathedral City	Palm Springs
Cedar Glen	Arrowhead
Cedar Pine	Arrowhead
Cedar Slope	San Joaquin Valley
Cedarpines Park	Arrowhead
Cerritos	Long Beach
Chalfant	Bishop

Table 1–2: City/Service Planning Directory
(Column 4 of 19)

City	Service Center
Chambless	Yucca Valley
Chapman Woods	Monrovia
Charter Oak	Covina
Chatsworth	Thousand Oaks
Cherry Valley	Redlands
Chilao	Monrovia
China Lake	Ridgecrest
Chino	Ontario
Chino Hills	Ontario
Cima	Barstow
City Terrace	Montebello
Claremont	Covina
Claremont	Ontario
Colton	Redlands
Commerce	Compton
Compton	Compton
Conejo Valley	Thousand Oaks
Convict Lake	Bishop
Corcoran	San Joaquin Valley
Cornell	Thousand Oaks
Corona	Ontario
Corona Del Mar	Huntington Beach
Coronita	Ontario
Coso	Ridgecrest
Costa Mesa	Huntington Beach
Coto de Caza	Saddleback
Cotton Center	San Joaquin Valley
Covina	Covina
Covina	Monrovia
Cowan Heights	Santa Ana
Crest Park	Arrowhead
Crestline	Arrowhead
Crestmore	Foothill
Crestview	Bishop
Crowley Lake	Bishop
Cucamonga	Ontario
Cudahy	Compton
Culver City	Santa Monica
Cuyama Valley	Antelope Valley
Cypress	Fullerton
Daggett	Barstow
Danby	Yucca Valley
Death Valley Junction	Ridgecrest
Deer Lodge Park	Arrowhead
Del Rosa	Redlands

REFERENCE NO. <i>PHH</i>	General Information	ESR–1
EFFECTIVE DATE 7-30-2004	Electrical Service Requirements ▶ SCE Public ◀	PAGE 1–7

Table 1–2: City/Service Planning Directory
(Column 5 of 19)

City	Service Center
Del Sur	Antelope Valley
Delano	San Joaquin Valley
Desert Center	Blythe
Desert Hot Springs	Palm Springs
Desert Lake	Ridgecrest
Desert Springs	Victorville
Devore	Foothill
Diamond Bar	Covina
Dinkey Creek	Shaver Lake
Dos Palmas	Palm Springs
Downey	Whittier
Doyle Springs	San Joaquin Valley
Duarte	Monrovia
Ducor	San Joaquin Valley
Dunmavin	Ridgecrest
Earlimart	San Joaquin Valley
East Highlands	Redlands
East Los Angeles	Montebello
East Pasadena	Monrovia
East San Gabriel	Montebello
East Tustin	Santa Ana
East Whittier	Whittier
Eastvale	Ontario
Eden Hot Springs	San Jacinto Valley
Edgemont	San Jacinto Valley
Edwards	Antelope Valley
Edwards	Ridgecrest
El Cerrito	Ontario
El Mirage	Victorville
El Modena	Santa Ana
El Monte	Montebello
El Porto	South Bay
El Rio	Ventura
El Segundo	South Bay
El Toro	Saddleback
Elizabeth Lake Ranch Club	Antelope Valley
Ellwood	Santa Barbara
Elsinore	San Jacinto Valley
Escondido Canyon	Valencia
Essex	Yucca Valley
Etiwanda	Foothill
Exeter	San Joaquin Valley
Fallbrook	San Jacinto Valley
Fallsvale	Redlands

Table 1–2: City/Service Planning Directory
(Column 6 of 19)

City	Service Center
Farmersville	San Jacinto Valley
Fawnskin	Victorville
Fenner	Yucca Valley
Fillmore	Ventura
Firestone Park	Compton
Flintridge	Monrovia
Florence	Compton
Fontana	Foothill
Forest Home	Redlands
Forest Park	Valencia
Fort Irwin	Barstow
Foster Park	Ventura
Fountain Springs	San Joaquin Valley
Fountain Valley	Huntington Beach
Frazier Park	Antelope Valley
Fremont Valley	Ridgecrest
Fresno	Shaver Lake
Friendly Hills	Whittier
Friendly Valley	Valencia
Fullerton	Fullerton
Furnace Creek	Ridgecrest
Garden City Acres	Ventura
Garden Grove	Santa Ana
Gardena	South Bay
Garlock	Ridgecrest
Garnet	Palm Springs
Gaviota	Santa Barbara
Giant Forest	San Joaquin Valley
Gilman Hot Springs	San Jacinto Valley
Glen Avon	Foothill
Glen Helen Ranch	Foothill
Glen Ivy	San Jacinto Valley
Glendora	Covina
Glennville	Kernville
Goffs	Yucca Valley
Golden Hills	Antelope Valley
Goldstone	Barstow
Goleta	Santa Barbara
Goodhope	San Jacinto Valley
Gorman	Antelope Valley
Goshen	San Joaquin Valley
Grand Terrace	Redlands
Grandview	Barstow
Grandview Palos Verdes	South Bay

ESR-1	General Information	REFERENCE NO. <i>PHH</i>
PAGE 1-8	Electrical Service Requirements ▶ SCE Public ◀	EFFECTIVE DATE 7-30-2004

Table 1–2: City/Service Planning Directory
(Column 7 of 19)

City	Service Center
Grangeville	San Joaquin Valley
Granite Station	Kernville
Grass Valley	Arrowhead
Green Acres	San Jacinto Valley
Green Valley	Antelope Valley
Green Valley Lake	Arrowhead
Greenhorn	Kernville
Guasti	Ontario
Guyama	Thousand Oaks
Hacienda Heights	Covina
Hacienda Heights	Whittier
Hammil	Bishop
Hanford	San Joaquin Valley
Harbor City	Compton
Harbor City	South Bay
Harvard	Barstow
Haskell Canyon	Valencia
Hasley Canyon	Valencia
Havasu Heights	Blythe
Havasu Lake	Blythe
Havasu Landing	Blythe
Havasu Palms	Blythe
Havilah	Kernville
Hawaiian Gardens	Long Beach
Hawes	Barstow
Hawthorne	South Bay
Hector	Barstow
Helendale	Victorville
Hemet	San Jacinto Valley
Hermosa Beach	South Bay
Hesperia	Victorville
Hidden Hills	Thousand Oaks
Hidden Valley	Antelope Valley
Hidden Valley	Thousand Oaks
Highgrove	Redlands
Highland	Redlands
Hinkley	Barstow
Hodge	Barstow
Hollydale	Compton
Hollywood by the Sea	Ventura
Hollywood Riviera	South Bay
Home Gardens	Ontario
Homeland	San Jacinto Valley
Homestead Area	Antelope Valley
Honby	Valencia

Table 1–2: City/Service Planning Directory
(Column 8 of 19)

City	Service Center
Hope Ranch	Santa Barbara
Horseshoe Bend	Arrowhead
Hueneme Bay	Ventura
Hungry Valley	Antelope Valley
Huntington Beach	Huntington Beach
Huntington Harbour	Huntington Beach
Huntington Lake	Shaver Lake
Huntington Park	Compton
Idyllwild	San Jacinto Valley
Indian Hills	Ontario
Indian Wells	Palms Springs
Industry	Covina
Industry	Montebello
Industry	Whittier
Inglewood	South Bay
Inyokern	Kernville
Inyokern	Ridgecrest
Irvine	Saddleback
Irwindale	Covina
Irwindale	Monrovia
Isla Vista	Santa Barbara
Ivanhoe	San Joaquin Valley
Ivanpah	Barstow
Jack Ranch	San Joaquin Valley
Jasmine	San Joaquin Valley
Johannesburg	Ridgecrest
Johnson Valley	Yucca Valley
Johnsondale	Kernville
Joshua Tree	Yucca Valley
June Lake	Mammoth
Kagel Canyon	Valencia
Kaweah	San Joaquin Valley
Keeler	Bishop
Keen Camp	San Jacinto Valley
Keene	Antelope Valley
Kelso	Barstow
Kelso	Yucca Valley
Kern River	Kernville
Kernvale	Kernville
Kernville	Kernville
Klondike	Barstow
Kramer	Ridgecrest
La Canada	Monrovia
La Conchita	Ventura
La Crescenta	Monrovia

REFERENCE NO. <i>PHH</i>	General Information	ESR-1
EFFECTIVE DATE 7-30-2004	Electrical Service Requirements ▶ SCE Public ◀	PAGE 1-9

Table 1–2: City/Service Planning Directory
(Column 9 of 19)

City	Service Center
La Habra	Whittier
La Habra	Fullerton
La Habra Heights	Fullerton
La Mirada	Whittier
La Mirada	Fullerton
La Palma	Fullerton
La Puente	Covina
La Sierra	Ontario
La Verne	Covina
Ladera Heights	South Bay
Laguna Beach	Saddleback
Laguna Hills	Saddleback
Laguna Niguel	Saddleback
Lake Arrowhead	Arrowhead
Lake Elizabeth Ranch Club	Antelope Valley
Lake Elsinore	San Jacinto Valley
Lake Forest	Saddleback
Lake Havasu	Blythe
Lake Hughes	Antelope Valley
Lake Isabella	Kernville
Lake Lindero	Thousand Oaks
Lake Los Angeles	Antelope Valley
Lake Mathews	San Jacinto Valley
Lake of the Woods	Valencia
Lake Sherwood	Thousand Oaks
Lake Silverwood	Arrowhead
Lake Tamarisk	Blythe
Lakebrook Park	Arrowhead
Lakeland Village	San Jacinto Valley
Lakeshore	Shaver Lake
Lakeview	San Jacinto Valley
Lakewood	Long Beach
Lancaster	Antelope Valley
Landers	Yucca Valley
Larchmont	Arrowhead
Las Posas Estate	Ventura
Lawndale	South Bay
Lebec	Antelope Valley
Lee Vining	Mammoth
Leisure World	Huntington Beach
Leliter	Ridgecrest
Lemon Cove	San Joaquin Valley
Lemon Heights	Santa Ana
Lemoore	San Joaquin Valley

Table 1–2: City/Service Planning Directory
(Column 10 of 19)

City	Service Center
Lennox	South Bay
Lenwood	Barstow
Leona Valley	Antelope Valley
Lido Isle	Huntington Beach
Limoneira	Ventura
Lindcove	San Joaquin Valley
Lindsay	San Joaquin Valley
Linnell	San Joaquin Valley
Little Lake	Ridgecrest
Little Tujunga	Valencia
Littlerock	Antelope Valley
Live Oaks Acres	Ventura
Llano	Antelope Valley
Llano	Victorville
Lockwood Valley	Antelope Valley
Loma Linda	Redlands
Lomita	South Bay
Lone Pine	Bishop
Long Beach	Compton
Long Beach	Long Beach
Lopez Canyon	Valencia
Los Alamitos	Long Beach
Los Angeles	Compton
Los Angeles	Santa Monica
Los Angeles	South Bay
Los Cerritos	Long Beach
Los Nietos	Whittier
Los Serranos	Ontario
Lucerne Valley	Yucca Valley
Lucerne Valley	Victorville
Ludlow	Barstow
Luring Pines	Arrowhead
Lynn Ranch	Thousand Oaks
Lynwood	Compton
Lytle Creek	Foothill
Malibu Beach	Thousand Oaks
Malibu Lake	Thousand Oaks
Malibu West	Thousand Oaks
Mammoth Lakes	Mammoth
Mammoth Mountain	Mammoth
Mandalay Bay	Ventura
Manhattan Beach	South Bay
Manix	Barstow
March Air Force Base	San Jacinto Valley

ESR-1	General Information	REFERENCE NO. <i>PHH</i>
PAGE 1-10	Electrical Service Requirements ▶ SCE Public ◀	EFFECTIVE DATE 7-30-2004

Table 1–2: City/Service Planning Directory
(Column 11 of 19)

City	Service Center
Maricopa	Ventura
Marina Del Rey	Santa Monica
Maywood	Compton
McFarland	San Joaquin Valley
McGee Creek	Bishop
McMillan Manor	Ventura
Mead Valley	San Jacinto Valley
Meadowbrook	Arrowhead
Meadowbrook Heights	San Jacinto Valley
Meiners Oaks	Ventura
Mentone	Redlands
Mesa Verde	Blythe
Mesquite	Barstow
Midway	Barstow
Midway City	Huntington Beach
Mint Canyon	Valencia
Mira Loma	Foothill
Mira Monte	Ventura
Miraleste	South Bay
Mission Viejo	Saddleback
Modjeska	Saddleback
Mojave	Tehachapi
Mojave	Ridgecrest
Monolith	Antelope Valley
Monrovia	Monrovia
Montalvo	Ventura
Montclair	Ontario
Monte Nido	Thousand Oaks
Montebello	Montebello
Montebello	Compton
Montecito	Santa Barbara
Monterey Park	Montebello
Montrose	Monrovia
Moorpark	Thousand Oaks
Moorpark	Ventura
Moorpark Home Acres	Thousand Oaks
Moreno	San Jacinto Valley
Morningside Park	South Bay
Morongo Indian Reservation	Palm Springs
Morongo Valley	Yucca Valley
Mount Baldy	Foothill
Mountclair	Foothill
Mount Wilson	Monrovia
Mountain Center	San Jacinto Valley
Mountain Pass	Barstow

Table 1–2: City/Service Planning Directory
(Column 12 of 19)

City	Service Center
Mountain Springs	Yucca Valley
Mupu	Ventura
Muroc	Ridgecrest
Murrieta	San Jacinto Valley
Murrieta Hot Springs	San Jacinto Valley
Muscoy	Redlands
Naples	Long Beach
Narod	Ontario
Needles	Yucca Valley
Needles Landing	Blythe
Neighbors	Blythe
Newberry Springs	Barstow
Newbury Park	Thousand Oaks
Newhall	Valencia
Newport Beach	Huntington Beach
Newport Coast	Huntington Beach
Nipton	Barstow
Norco	Ontario
North Edwards	Ridgecrest
North Fork Saddle	Valencia
North Long Beach	Long Beach
North Oaks	Valencia
North Palm Springs	Palm Springs
North Ventura	Ventura
Norton Air Force Base	Redlands
Norwalk	Whittier
Nuevo	San Jacinto Valley
Nyeland Acres	Ventura
Oak Glen	Redlands
Oak Hills	Victorville
Oak View	Ventura
Oakbrook Village	Thousand Oaks
Ocean Park	Santa Monica
Ojai	Ventura
Olancha	Ridgecrest
Olive	Santa Ana
Ontario	Ontario
Ontario	Foothill
Onyx	Kernville
Orange	Santa Ana
Orange Park Acres	Santa Ana
Oro Grande	Victorville
Oxnard	Ventura
Oxnard Beaches	Ventura
Oxnard Shores	Ventura

REFERENCE NO. <i>PHH</i>	General Information	ESR–1
EFFECTIVE DATE 7-30-2004	Electrical Service Requirements ▶ SCE Public ◀	PAGE 1–11

Table 1–2: City/Service Planning Directory
(Column 13 of 19)

City	Service Center
Pacoima Canyon	Valencia
Pahrump	Barstow
Painted Cave	Santa Barbara
Painted Hills	Palm Springs
Palm Desert	Palm Springs
Palm Desert Country Club	Palm Springs
Palm Springs	Palm Springs
Palm Springs Oasis	Palm Springs
Palm Wells	Yucca Valley
Palmdale	Antelope Valley
Palo Verde	Blythe
Palos Verdes Estates	South Bay
Palos Verdes Peninsula	South Bay
Panorama Heights	Kernville
Panorama Park	Kernville
Paradise Camp	Santa Barbara
Paramount	Compton
Park El Moreno	San Jacinto Valley
Parker Dam	Blythe
Pasadena	Monrovia
Patton	Redlands
Pearblossom	Antelope Valley
Pearsonville	Ridgecrest
Perchanga Indian Reservation	San Jacinto Valley
Pedley	Foothill
Pelissier Village	Whittier
Perris	Ontario
Perris	San Jacinto Valley
Phelan	Victorville
Pico Canyon	Valencia
Pico Rivera	Whittier
Pico Rivera	Montebello
Pine Cove	San Jacinto Valley
Pine Flat	San Joaquin Valley
Pine Mountain Club	Valencia
Pinon Hills	Victorville
Pinon Pines	Valencia
Pioneer Point	Ridgecrest
Pioneertown	Yucca Valley
Piru	Valencia
Pixley	San Joaquin Valley
Placentia	Fullerton
Placerita Canyon	Valencia
Plainview	San Joaquin Valley

Table 1–2: City/Service Planning Directory
(Column 14 of 19)

City	Service Center
Plant 42	Antelope Valley
Point Mugu	Ventura
Point of Rocks	Ridgecrest
Pomona	Covina
Pomona	Ontario
Pond	San Joaquin Valley
Ponderosa	San Joaquin Valley
Poplar	San Joaquin Valley
Poppet Flats	San Jacinto Valley
Port Hueneme	Ventura
Portal Heights	Antelope Valley
Porterville	San Joaquin Valley
Portugese Bend	South Bay
Posey	Kernville
Poso Park	Kernville
Potrero Heights	Montebello
Quail Valley	San Jacinto Valley
Quartz Hill	Antelope Valley
Rainbow Canyon	San Jacinto Valley
Rancho California	San Jacinto Valley
Rancho Cucamonga	Foothill
Rancho Cucamonga	Ontario
Rancho Mirage	Palm Springs
Rancho Palos Verdes	South Bay
Rancho Santa Margarita	Saddleback
Rancho Sespe	Ventura
Randsburg	Ridgecrest
Reche Canyon	Redlands
Red Hill	Santa Ana
Red Mountain	San Jacinto Valley
Red Mountain	Ridgecrest
Red Rover Canyon	Valencia
Redlands	Redlands
Redondo Beach	South Bay
Refugio	Santa Barbara
Rialto	Foothill
Richgrove	San Joaquin Valley
Ridgecrest	Ridgecrest
Rimforest	Arrowhead
Ripley	Blythe
Riverside	Redlands
Riverside	Ontario
Riverside	San Jacinto Valley
Roads End	Blythe

ESR-1	General Information	REFERENCE NO. <i>PhH</i>
PAGE 1-12	Electrical Service Requirements ▶ SCE Public ◀	EFFECTIVE DATE 7-30-2004

Table 1–2: City/Service Planning Directory
(Column 15 of 19)

City	Service Center
Rolling Hills	South Bay
Rolling Hills Estates	South Bay
Romoland	San Jacinto Valley
Rosamond	Antelope Valley
Rosemead	Montebello
Rossmoor	Long Beach
Rowco	Arrowhead
Rowland Heights	Covina
Rubidoux	Foothill
Running Springs	Arrowhead
Ryan	Ridgecrest
Sage	San Jacinto Valley
Saltdale	Ridgecrest
Saltus	Yucca Valley
San Bernardino	Redlands
San Dimas	Covina
San Dimas Canyon	Covina
San Fernando	Valencia
San Francisquito Canyon	Valencia
San Gabriel	Monrovia
San Gabriel	Montebello
San Jacinto	San Jacinto Valley
San Manuel Indian Reservation	Redlands
San Marino	Monrovia
San Moritz	Arrowhead
San Pedro	South Bay
San Sevaime Peak	Foothill
Sand Canyon	Valencia
Santa Ana	Santa Ana
Santa Ana	Saddleback
Santa Barbara	Santa Barbara
Santa Clarita	Valencia
Santa Fe Springs	Whittier
Santa Monica	Santa Monica
Santa Paula	Ventura
Santa Rosa Valley	Ventura
Santa Susana	Thousand Oaks
Saticoy	Ventura
Saugus	Valencia
Scotland	Foothill
Scotty's Castle	Ridgecrest
Seal Beach	Huntington Beach
Seal Beach	Long Beach
Searles	Ridgecrest
Sedco	San Jacinto Valley

Table 1–2: City/Service Planning Directory
(Column 16 of 19)

City	Service Center
Seeley Flat	Arrowhead
Seminole Hot Springs	Thousand Oaks
Sequoia Crest	San Joaquin Valley
Sequoia National Park	San Joaquin Valley
Seven Oaks	Redlands
Shaver Lake	Shaver Lake
Shosone	Barstow
Siberia	Barstow
Sierra Madre	Monrovia
Signal Hill	Long Beach
Silver Strand	Ventura
Silverado	Saddleback
Simi Valley	Thousand Oaks
Sky Forest	Arrowhead
Skyland	Arrowhead
Sleepy Valley	Valencia
Smiley Park	Arrowhead
Snow Valley	Arrowhead
Snowcreek	Palm Springs
South San Gabriel	Montebello
Soboba Hot Springs	San Jacinto Valley
Soledad Canyon	Valencia
Solemint	Valencia
Solromar	Thousand Oaks
Somis	Thousand Oaks
Somis	Ventura
South El Monte	Montebello
South Gate	Compton
South Glen Avon	Ontario
South Laguna	Saddleback
South Pasadena	Monrovia
South Whittier	Whittier
Springville	San Joaquin Valley
Stallion Springs	Antelope Valley
Stanton	Fullerton
Stovepipe Wells	Ridgecrest
Strathmore	San Joaquin Valley
Strawberry Flats	Arrowhead
Sugarload	Kernville
Sulphur Mtn. Springs	Ventura
Summerland	Santa Barbara
Summit	Arrowhead
Summit	Victorville
Summit Valley	Victorville
Sun City	San Jacinto Valley

REFERENCE NO. <i>PHH</i>	General Information	ESR-1
EFFECTIVE DATE 7-30-2004	Electrical Service Requirements ▶ SCE Public ◀	PAGE 1-13

Table 1–2: City/Service Planning Directory
(Column 17 of 19)

City	Service Center
Sun Village	Antelope Valley
Sungold	Whittier
Sunland	Monrovia
Sunny Slope	Foothill
Sunnymead	San Jacinto Valley
Sunnyslope	Monrovia
Sunset Beach	Huntington Beach
Sunset Hills	Thousand Oaks
Sunset Park	Arrowhead
Surfside	Huntington Beach
Susana Knolls	Thousand Oaks
Switzerland	Arrowhead
Tajiguas	Santa Barbara
Tecopa	Barstow
Tehachapi	Tehachapi
Temecula	San Jacinto Valley
Temescal Canyon	San Jacinto Valley
Temple City	Monrovia
Terminal Island	Long Beach
Terra Bella	San Joaquin Valley
Teviston	San Joaquin Valley
Thousand Oaks	Thousand Oaks
Three Points	Antelope Valley
Three Rivers	San Joaquin Valley
Tick Canyon	Valencia
Tipton	San Joaquin Valley
Toms Place	Bishop
Tonyvile	San Joaquin Valley
Topanga Canyon	Thousand Oaks
Torrance	Compton
Torrance	South Bay
Trabuco	Saddleback
Trona	Ridgecrest
Tulare	San Joaquin Valley
Tule Indian Reservation	San Joaquin Valley
Tustin	Santa Ana
Twentynine Palms	Yucca Valley
Twin Lakes	Thousand Oaks
Twin Lakes Bridgeport	Bishop
Twin Lakes Mammoth	Bishop
Twin Peaks	Arrowhead
U. S. Marine Corps	Barstow
Universal City	Valencia
Upland	Ontario

Table 1–2: City/Service Planning Directory
(Column 18 of 19)

City	Service Center
Val Verde	San Jacinto Valley
Val Verde Park	Valencia
Valencia	Valencia
Valinda	Covina
Valle Vista	San Jacinto Valley
Valley of Enchantment	Arrowhead
Valleyview Park	Arrowhead
Valyermo	Antelope Valley
Vasquez Canyon	Valencia
Venice	Santa Monica
Ventucopa	Ventura
Ventura	Santa Barbara
Ventura	Ventura
Verdemont	Redlands
Veterans Hospital	Santa Monica
Victorville	Victorville
View Park	South Bay
Villa Park	Santa Ana
Virginia Colony	Thousand Oaks
Visalia	San Joaquin Valley
Wagon Wheel	Ventura
Walker Basin	Kernville
Walnut	Covina
Walnut Park	Compton
Walteria	South Bay
Warm Springs Canyon	Valencia
Warner Tract	San Jacinto Valley
Waterman Canyon	Redlands
Waukena	San Joaquin Valley
Weldon	Kernville
West Covina	Covina
West Hollywood	Santa Monica
West Palm Springs	Palm Springs
West Riverside	Ontario
Westend	Ridgecrest
Westlake Village	Thousand Oaks
Westminster	Huntington Beach
Wheeler's Hot Springs	Ventura
Whitewater	Palm Springs
Whittier	Montebello
Whittier	Whittier
Whittier	Fullerton
Whittwood	Whittier
Wildomar	San Jacinto Valley

ESR-1	General Information	REFERENCE NO. <i>PHH</i>
PAGE 1-14	Electrical Service Requirements ▶ SCE Public ◀	EFFECTIVE DATE 7-30-2004

Table 1-2: City/Service Planning Directory
(Column 19 of 19)

City	Service Center
Willow Springs	Antelope Valley
Willowbrook	Compton
Wilmington	South Bay
Wilmington	Long Beach
Winchester	San Jacinto Valley
Windsor Hills	South Bay
Wofford Heights	Kernville
Woodcrest	San Jacinto Valley
Woodlake	San Joaquin Valley
Woodland Hills	Thousand Oaks
Woodville	San Joaquin Valley
Woody	San Joaquin Valley
Wrightwood	Victorville
Yates Well	Barstow
Yermo	Barstow
Yettem	San Joaquin Valley
Yorba Linda	Fullerton
Yosemite	Bishop
Yucaipa	Redlands
Yucca Valley	Victorville
Yucca Valley	Yucca Valley
Zuma Beach	Thousand Oaks

REFERENCE NO. <i>PhH</i>	General Information	ESR-1
EFFECTIVE DATE 7-30-2004	Electrical Service Requirements ▶ SCE Public ◀	PAGE 1-15

3.0 Energy Management Programs

Edison offers several energy management programs tailored to assist residential, commercial, industrial, and agricultural customers in minimizing energy costs. For specific information regarding these programs call (800) 990-7788, or (800) 655-4555. Information is also available at our website: <http://www.sce.com/>.

3.1 Residential

Customer Assistance Programs: Edison's Customer Assistance Programs (CAP) are designed to help low-income customers conserve energy and control their electricity costs. Renters and homeowners may qualify. To be eligible, Edison customers must meet specific income guidelines established by the California Public Utilities Commission. For more information call (800) 736-4777.

3.2 Commercial/Industrial/Agricultural

New Construction: Edison's "New Construction" program is targeted to builders, developers, contractors, engineers, and architects and promotes the benefits of designing energy efficiency into projects. Incentives may be offered for energy-efficient space conditioning equipment, daylighting controls, building envelopes, and control systems which exceed State standards.

4.0 Dig Alert

The State of California Government Code 4216 mandates that anyone doing excavation work shall call at least two (2) working days prior to commencement of any excavation.^{1/} If you are performing this type of work in California or Nevada, please call Underground Service Alert at 800-227-2600.

5.0 Electric Vehicles

Edison offers special electric rates and information for new electric vehicle (EV) purchasers and operators. EVs are defined as vehicles powered by electric motors which are licensed for street use. In residential applications, special second meter adapters may be available which are provided, owned, and maintained by Southern California Edison.

Due to the numerous electrical service panel configurations, customers are recommended to contact the local Service Planning office for details, or contact SCEs EV information Hotline at (800) 366-7766.

6.0 Voltage Standards

6.1 Standard Distribution Voltages

The Company will supply the following standard nominal distribution voltages:

Single Phase. 120, 120/240, 240, 240/480, and depending on the location, 120/208, 2,400, 12,000, or 16,500 volts.

Three Phase. 120/208, 240, 277/480, 2,400, 4160, and depending on the location, 4,800, 12,000, 14,400/24,900, 13,800, 16,500, or 33,000 volts.

Exceptions:

- A. 120/240 volts – Four-wire delta will only be supplied under special conditions, contact the Company local Service Planning office for details.

1/ This is to prevent damage to underground facilities.

ESR-1	General Information	REFERENCE NO. <i>PhH</i>
PAGE 1-16	Electrical Service Requirements ▶ SCE Public ◀	EFFECTIVE DATE 7-30-2004

- B. Existing 480 volt delta service installations contemplating an increase in load may continue to be served three wire as long as the customer's service equipment has sufficient capacity to carry the additional load. If the existing transformer bank must be changed to service the new load, the neutral shall not be grounded or run with the service. If the customer must change their service equipment, service shall be provided at 277/480 volt, Wye connection.

If an existing transformer bank has sufficient capacity and a new customer desires service, they may be provided a 480 volt delta service.

6.2 Customer Service Voltages

Under all normal load conditions, distribution circuits will be operated so as to maintain secondary service voltage levels at the service point within the voltage ranges specified in [Table 1-3 \(page 1-17\)](#).

Table 1-3: Customer Service Voltages

Nominal Two-wire and Multi-Wire Service Voltage	Minimum Voltages to All Services	Maximum Service Voltages on Residential and Commercial Distribution Circuits	Maximum Service Voltages on Agricultural and Industrial Distribution Circuits
120	114	120	126
208	197	208	218
240	228	240	252
277	263	277	291
480	456	480	504

Note: Exceptions to Voltage Limits. Voltage may be outside the limits specified when the variations:

1. Result from the temporary action of the elements.
2. Are infrequent momentary fluctuations of a short duration.
3. Result from service interruptions.
4. Result from temporary separation of parts of the system from the main system.
5. Are from causes beyond the control of the Company.

6.3 Customer Utilization Voltages

All customer-owned utilization equipment must be designed and rated in accordance with the following utilization voltages specified by the American National Standard Institute (ANSI) C84. 1 if customer equipment is to give fully satisfactory performance:

Table 1-4: Customer Utilization Voltages

Nominal Utilization Voltage	Minimum Utilization Voltage	Maximum Utilization Voltage
120	110	125
208	191	216
240	220	250
277	254	289
480	440	500

REFERENCE NO. <i>PhH</i>	General Information	ESR-1
EFFECTIVE DATE 7-30-2004	Electrical Service Requirements ▶ SCE Public ◀	PAGE 1-17

Minimum utilization voltages from ANSI C84.1 are shown for customer information only as the Company has no control over voltage drop in customer's wiring.

7.0 Customer Transformation and Harmonic Interference

In order to prevent third harmonic interference, the following requirements will apply to the delivery of all (and only) three-phase high or low voltage service to be transformed by the customer to different values.

7.1 High Voltage Service:

Where the customer desires to take three-phase high voltage service delivery and transform the service delivery voltage to 120/208 volts wye or 277/480 volts wye, or to install any other transformation which would involve the use of a wye connection to supply the desired utilization voltage, the Company will supply at its option either 4,160, 4,800, 7,200, 12,000, 16,500 or 33,000 volts.

Where service to the customer is delivered directly from the Company's 2,400, 4,160, 4,800, 7,200, 12,000, 16,500, or 33,000 volt circuits, single-phase or three-phase transformers having the same primary voltage rating as the service delivery voltage, with their primary windings connected in delta, are acceptable. In the event that the Company converts its primary distribution system from 2.4 kV delta to 4.16 kV wye, the Company will supply the material and labor to convert an existing transformer installation to comply with this requirement.

Where service is delivered to the customer from the Company's bank of delta-wye, wye-delta, or delta-delta connected transformers which is located on the customer's premises, the Company has no requirements for wye or delta connection of transformers installed by the customer.

7.2 Low Voltage Service:

Where three-phase service is delivered to the customer at 240 volts and the customer desires to transform to a different voltage, the customer may only connect a delta primary transformer to the Company service.

Where an established three-phase 480 volt combination light and power service is delivered to the customer, the customer may establish a three-phase 4-wire 277/480 volt grounded neutral system on the load side of their main disconnect. An artificial neutral would be derived from an approved single winding type grounding transformer furnished and installed by the customer. This arrangement will be acceptable to the Company only in cases where the Company's transformers are located on the customer's premises and supply one service at three-phase 3-wire 480 volt exclusively.

8.0 Agricultural Power Service Three-Phase 240 and 277/480 Volts

Three-phase 240 and 277/480 volt agricultural service will be supplied by the normal method whereby the customer supplies complete service facilities.

Exception:

Agricultural customers relocating serviceable three-phase 480 volt three-wire service equipment, may be provided a three wire service.

ESR-1	General Information	REFERENCE NO. <i>PhH</i>
PAGE 1-18	Electrical Service Requirements ▶ SCE Public ◀	EFFECTIVE DATE 7-30-2004

8.1 100 Amp Service

Where the nameplate horsepower rating of any motor does not exceed 30 HP 240 volts or 60 HP 277/480 volts, a factory bussed safety socket box with a 100 ampere rating shall be installed.

The meter socket for 240 volt service will be 5 or 7 clip, depending on the grounding of the serving transformer bank. The meter socket for 277/480 volt service will be 7 clip. Consult your local Service Planning office before purchasing or installing service equipment.

The maximum wire size or current carrying capacity of the conductors installed in the customers service raceway shall not exceed that of No. 1 wire, and the conduit size of such raceway shall not exceed 1-1/2 inches. The capacity of the customer's service switch is not limited under these conditions.

The total actual continuous operating load current, excluding motor starting current, shall not exceed 80 amperes.

8.2 200 Amp Service

Where the nameplate horsepower rating of any motor does not exceed 60 HP 240 volts or 125 HP 277/480 volts, a factory bussed safety socket box with a 200 ampere rating shall be installed.

The meter socket for 240 volt service will be 5 or 7 clip, depending on the grounding of the serving transformer bank. The meter socket for 277/480 volt service will be 7 clip. Consult your local Service Planning office before purchasing or installing service equipment.

The maximum wire size or current carrying capacity of the conductors installed in the customer's service raceway shall not exceed that of NO. 3/0 wire and the conduit size of any such raceway shall not exceed 2 inches. The capacity of the customer's service switch is not limited under these conditions.

The total actual continuous operating load current, excluding motor starting current, shall not exceed 160 amperes.

8.3 Above 200 Amp Service

If the total actual operating load current, excluding motor starting current, for any reason exceeds 160 amperes, either at the time of installation or thereafter, the customer shall at such times have complete facilities installed (at their expense) consisting of an approved instrument transformer box or an approved switchboard. See [ESR-5: Section 10.0 "Current Transformer Cabinet & Meter Socket Panel"](#), [ESR-5: Figure 5-12](#), [ESR-5: Figure 5-13](#) or [ESR-6: Figure 6-1](#).

9.0 Overhead Service

9.1 To Customer's Service and Meter Pole

See [Figure 2-13: Temporary Service Requirements \(Service for One Year or Less\)](#) and [Figure 2-15: Customer Owned Permanent or Temporary Service Pole](#).

REFERENCE NO. <i>PHH</i>	General Information	ESR-1
EFFECTIVE DATE 7-30-2004	Electrical Service Requirements ▶ SCE Public ◀	PAGE 1-19

9.2 To Customer's Building or Structure

The Company will install overhead service drops, to a building or structure, which is adequate to support the service and meter equipment. This type of service will not be rendered to wind machine towers or columns, or similar equipment subject to excessive vibration. For these types of installations, the meter box shall be installed on a separate vibration-free structure. The service conduit, if attached to the structure, shall descend into the concrete base and rise up into the meter structure. For additional Overhead Service Information see [ESR-2: Overhead Service Connections 0-600 Volts](#).

10.0 Underground Service

10.1 To Customer's Service and Meter Post

See [Figure 3-15: Plug-In Temporary \(Piggy Back\) Service Adapter](#), [Figure 3-16: Temporary Service From A Padmount Transformer](#) and [Figure 3-17: Temporary Service From Secondary Hand Hole, Pull Box or Pedestal](#).

10.2 To Customer's Building or Structure

See [ESR-3: Underground Service Connections 0-600 Volts](#).

11.0 Service or Meter Switch—General Requirements

A disconnecting means with overcurrent protection is required at the meter location. In some cases it is a single switch or circuit breaker. In other cases, where permitted by the Company and by inspection authorities, it may be a group of switches or circuit breakers, per N.E.C. 230-71.

A service or meter switch as defined above shall be furnished and installed by the customer in every service proposed to be supplied with electric energy from the Company's system as specified in these Requirements.

12.0 Customer Generators

Customer generators shall not be switched or operated in parallel with the Edison system without Company approval. Paralleling shall be in accordance with requirements of the applicable tariff schedules or special parallel generation agreements. Customers and consultants should contact the local SCE Service Planning office for details.

When a customer has a standby generator to supply all of their load during an Edison system outage, the generator shall be connected to the load by a double throw switch or automatic relays and switches which will isolate the load from the Edison system before the generator is connected to the load. When the Edison service is re-energized, the generator will then be isolated from the load before the load is reconnected to the Edison system.

12.1 Rule 21 Net Generation Output (NGO) Metering

Rule 21 output metering is required for most customer generator installations where the generator is installed and intended to operate in parallel with the SCE distribution system for extended periods of time. NGO metering is required to provide revenue grade metering data for "non-bypassable charges" to the various categories of customers who serve all or a portion of their electrical energy needs from a source other than SCE. NGO metering shall be located in a customer's circuitry at a location that will facilitate measuring "net" generator output. Customer load circuits cannot be connected between the generator and the NGO metering. Generator auxiliary loads (loads necessary for generator operation only) can be connected between the generator and the NGO metering.

ESR-1	General Information	REFERENCE NO. <i>PhH</i>
PAGE 1-20	Electrical Service Requirements ▶ SCE Public ◀	EFFECTIVE DATE 7-30-2004

NGO metering may also be used by SCE for the other reasons permitted under Rule 21.f. NGO metering panels, metering switchboards, and medium voltage metering sections shall be fabricated in a manner as specified in SCE's Electrical Service requirements. NGO Metering supplied by SCE shall be revenue grade and installed in equipment fabricated to the specific requirements found within this manual.

A. Equipment Review

Plans for specific service equipment designed to accept utility supplied NGO metering and associated equipment shall be submitted to SCE for review and approval prior to fabrication and installation. The manufacturer shall submit 3 copies of the equipment drawings to the local Service Planning Office, or assigned SCE engineer for review and approval. When service equipment for NGO metering is improperly engineered and installed and the company was not contacted in advance, the customer shall be responsible for all modifications and the costs to provide the same.

B. Location and Access

NGO metering and devices may, but are not required to be grouped with the Point of Common Coupling (PCC) revenue metering that is used to measure energy delivered to a customer from SCE's Distribution System. Where NGO metering sections are located in the same switchboard, switchgear or metering location as the PCC metering, the customer shall install a 1-1/2 inch conduit between the PCC and NGO metering current transformer compartments. The conduit shall enter the current transformer compartments in the front, against the side with hinges on the door. NGO metering locations shall be accessible to SCE on a continuous (24 hr) basis, or as otherwise agreed to between customer and SCE.

NGO metering panels and devices shall be installed in accordance with all of SCE's applicable Electrical Service Requirements work clearances and specifications. Service equipment proposed by customer to accept utility NGO metering equipment shall be reviewed and approved by SCE prior to installation. Service equipment installed by customer to accept utility NGO metering, shall be inspected and approved by any authority having jurisdiction over customer's equipment prior to the installation of SCE's meter and/or equipment.

C. Equipment Marking/Labeling

NGO metering equipment shall be permanently labeled "Net Generation Output Metering." The label shall be located on the meter panel or adjacent to the meter socket. Acceptable methods for labeling customer NGO metering sections or panel(s) shall be either by permanently attached machine engraved laminated phenolic (or equal) tags, or permanent stenciled paint lettering. All lettering shall be a minimum one-quarter inch in height. When self-contained (non-instrument rated) metering is supplied by SCE for NGO metering purposes, a safety socket box with factory installed test-bypass blocks is required. When switchboards or switchgear are installed, the customer shall provide a tag or other identification method to indicate which bus or cable direction from the NGO metering connects to the generator output. Typically, the marking should read "top generator fed" or "bottom generator fed." If the NGO metering equipment and PCC metering equipment are separated by a distance of more than 100 feet, or are located on different levels or floors, then a permanent sign shall be placed at the PCC metering location which states the location of the NGO metering equipment.

REFERENCE NO. <i>PhH</i>	General Information	ESR-1
EFFECTIVE DATE 7-30-2004	Electrical Service Requirements ▶ SCE Public ◀	PAGE 1-21

D. Prohibited Metering Locations

NGO metering panels, switchboards, or medium voltage metering sections shall not be located in prohibited meter locations found in **ESR-5: Table 5-2 "Prohibited Meter Locations"** or as otherwise deemed unacceptable to SCE. NGO metering locations shall be reviewed and approved by SCE prior to installation.

E. Switch and Disconnect Requirements

For low voltage (less than 600 volts) switchboards and high voltage (above 600 volts) switchgear, the electrical system shall be engineered so that the NGO metering section can be de-energized and isolated so that SCE workmen can work on the metering equipment without inadvertent closing of isolation devices. NGO metering sections shall be isolated by either lockable open or rackable open circuit breakers and/or open and lockable disconnect switches. Isolation devices shall have signage that clearly indicates open positions and provisions for SCE to place a company padlock on such devices. It is the responsibility of the customer to operate such devices and de-energize NGO metering upon SCE request. It is recommended, but not required, that the lockable open devices need to be located to isolate the NGO meter section only. This will facilitate isolating the NGO metering section without interrupting customer load.

F. Voltage Standards

If a customer installs a generator utilizing a voltage not listed in **ESR-6: Section 1.0 "Switchboards 600 Volts and Below"** of this manual, then the customer will be required to install, own, and maintain a transformer to match SCE's service voltage. NGO metering sections provided by customers shall be located on the utility (SCE) side of this voltage-matching transformer unless host loads are connected at the generator voltage on the generator side of this transformer.

G. Safety Socket Box with factory Installed Test-Bypass

All NGO metering installations requiring metering service equipment at or below 200 amp shall use a factory wired safety socket box. The specifications for this panel can be found in **ESR-5: Section 9.0 "Factory Wired Safety Socket Boxes"**. The wiring sequence of factory installed test by-pass blocks, from left to right, is LINE-LOAD, LINE-LOAD, LINE-LOAD. For NGO metering purposes, the generator output conductor shall be connected to the terminal marked "LINE." The bypass block terminal marked "LOAD" of the safety socket box shall continue the output feed beyond the NGO metering safety socket box.

Written requests for information about Rule 21 may be mailed to SCE at the following address:

Southern California Edison Company
Attention: Distributed Generation Administrator
2244 Walnut Grove Avenue, Q4D
Rosemead, CA, 91770

Alternatively, customers may contact SCE Regarding Distributed Generation or Rule 21 interconnection requirements at 626-302-9521 or by sending an e-mail to SCE at customer.generation@sce.com.

ESR-1	General Information	REFERENCE NO. <i>PhH</i>
PAGE 1-22	Electrical Service Requirements ▶ SCE Public ◀	EFFECTIVE DATE 7-30-2004

13.0 Short-Circuit Current

Where state and/or local building inspection agencies require that customers install service equipment with overcurrent protective devices with a short-circuit rating equal to or not less than the available short-circuit current at its supply terminal, the customer should obtain from the Company the Company's contribution to short-circuit currents at the customer's service entrance.

The Company's contribution to short-circuit currents, at the customer's service entrance, will be as follows for the applicable type of service to be rendered.

13.1 10,000 Amps and Below

The Company's contribution to the available short-circuit current at the service entrance will not exceed 10,000 amperes for single-family dwellings, duplexes, or individually metered mobile homes which utilize self-contained type Company meters.

Temporary service, when served from a single-phase 120/240 volt transformer will not exceed 10,000 amperes.

13.2 Greater than 10,000 Amps

Multi-Family Residential (Three or More Grouped Meters), Commercial, and Industrial.

Table 1-5: Short-Circuit Current

Phase	Serving Voltage	Service Entrance Ampacities	Utilities Contribution to Fault Current Will Not Exceed
Single-phase	120/240	600 amps or less	42,000
Three-phase	120/208 or 240	800 amps or less	42,000
Three-phase	480	1,200 amps or less	30,000

13.3 Exceptional Cases

When the application of the above fault current limitation appears too restrictive for new installations, the customer may request the utility to provide the available fault currents for a specific case and location.

All new installations with service voltage or service entrance ampacities larger than those stated above will be handled as individual cases and the Company will provide the available fault duty for each installation.

14.0 Electric-Magnetic Fields

Electric and magnetic fields are also known as "electromagnetic fields" or "EMF." Electric and magnetic fields are a natural result consequence of electricity. Whenever an electric charge, or current, is present-either natural or man-made electric and magnetic fields occur. Electric power distribution facilities generate both electric and magnetic fields.

14.1 Electric Fields

Electric fields result when voltage is present. The strength "E" of electric fields is represented by volts per meter. As the distance increases from the source, the electric field strength decreases rapidly.

REFERENCE NO. <i>PhH</i>	General Information	ESR-1
EFFECTIVE DATE 7-30-2004	Electrical Service Requirements ▶ SCE Public ◀	PAGE 1-23

Any conducting surface such as a roof, metallic fence, or soil will shield electric fields. Therefore, underground cables, padmount equipment and wires in metallic conduit DO NOT expose the public to electric fields, and are not a primary concern in this document.

14.2 Magnetic Fields

Magnetic fields are caused by current flowing in conductors, regardless of the voltage present. The magnetic field typically surrounds a current-carrying conductor in a cylindrical fashion.

The strength "B" of magnetic fields is represented by milliGauss (mG). As the distance increases from the source, the magnetic field strength decreases rapidly. Conducting materials, such as earth and metal, usually have little effect on magnetic fields.

14.3 Edison's Corporate EMF Policy

After many years of research, scientists have not found that exposure to power-frequency electric and magnetic fields (EMF) causes disease in humans. Research on this topic is continuing.

We are aware that some members of the public are concerned about the potential health effects of power-frequency electric and magnetic fields. We recognize and take seriously our responsibilities to help resolve these concerns. Realizing that we need to better understand electric and magnetic fields and respond to the current uncertainty, we believe Edison's responsibilities are to:

- Provide balanced, accurate information to our employees, customers, and public agencies, including providing EMF measurements and consultation customers upon request.
- Support existing research programs at the California Department of Health Services and National Institute of Environmental Health Sciences to resolve the key scientific questions about EMF.
- Conduct research to develop and evaluate no- and low-cost designs for reducing fields from electric utility facilities.
- Take appropriate no- and low-cost steps to minimize field exposures from new facilities and continue to consult and advise our customers with respect to existing facilities.
- Research and evaluate occupational health implications and provide employees who work near energized equipment with timely, accurate information about field exposure in their work environment.
- Assist the California Department of Health Services, the California Public Utilities Commission, and other appropriate local, state, and federal governmental bodies to provide reasonable, uniform regulatory guidance.

14.4 Sources of Magnetic Fields

Figure 1-1 (page 1-25) shows the sources of magnetic fields in and around a typical residence. These sources also exist in and around other buildings, such as: schools, offices, stores, and businesses. As current flows from Edison's transmission and distribution facilities, electric and magnetic fields can be detected and measured near wiring and electrical appliances, where currents are present.

ESR-1	General Information	REFERENCE NO. <i>PhH</i>
PAGE 1-24	Electrical Service Requirements ▶ SCE Public ◀	EFFECTIVE DATE 7-30-2004

Figure 1-1: Sources of Magnetic Fields

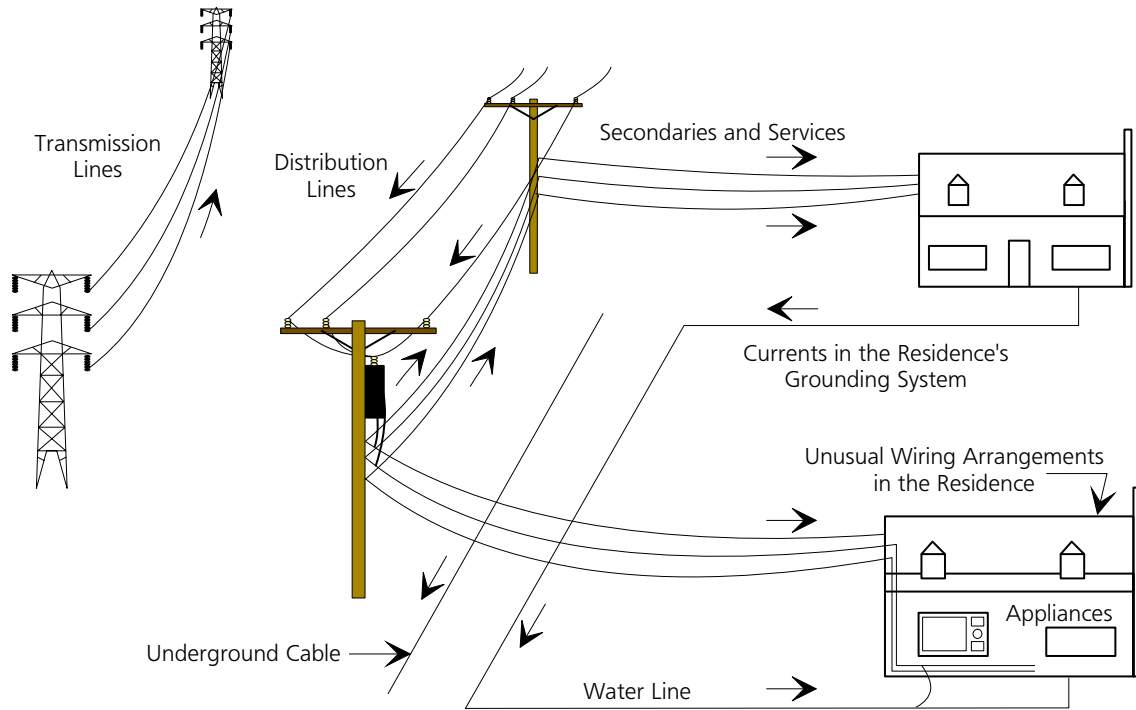

Table 1-6 shows magnetic field strength levels for various household appliances, which range as high as 20,000 mG for a hair dryer. Notice how quickly the magnetic field strength levels decrease as the distances from appliances increase.

Table 1-6: Magnetic Fields From Electrical Appliances^(a)

Appliances	Magnetic Field (milliGauss)		
	1.2 inches	12 inches	39 inches
Electric Blanket	2-80	—	—
Clothes Washer	8-400	2-30	0.1-2
Television	25-500	0.4-20	0.1-2
Electric Range	60-2,000	4-40	0.1-1
Microwave Oven	750-2,000	40-80	3-8
Electric Shaver	150-15,000	—	—
Fluorescent Lamp	400-4,000	5-20	0.1-3
Hair Dryer	60-20,000	1-70	0.1-3

(a) Source: SCE Questions & Answers About Electric and Magnetic Fields, page 13.

REFERENCE NO. <i>PHH</i>	General Information	ESR-1
EFFECTIVE DATE 7-30-2004	Electrical Service Requirements ▶ SCE Public ◀	PAGE 1-25

14.5 Magnetic Field Management Techniques

Generally, the following methods will minimize the public exposure to magnetic fields near overhead and underground electrical equipment^{2/}:

- Place wires and conductors close together.
- Place overhead conductors as far away as reasonable from foot traffic and normally occupied spaces.
- Bury underground conductors in trenches and conduits as deep as reasonable especially in areas near foot traffic or normally occupies spaces.
- Place meter panels on unoccupied areas of the building such as garages, storerooms, etc. **Figure 1-2 (page 1-26).**
- Place transformers as far away from occupied areas as practical and design location to discourage loitering by the public.
- Locate transformers away from occupiees areas, orient secondary side away from pedestrian access and occupied areas. See **Figure 1-3 (page 1-27).**

Figure 1-2: Meter Panel Locations

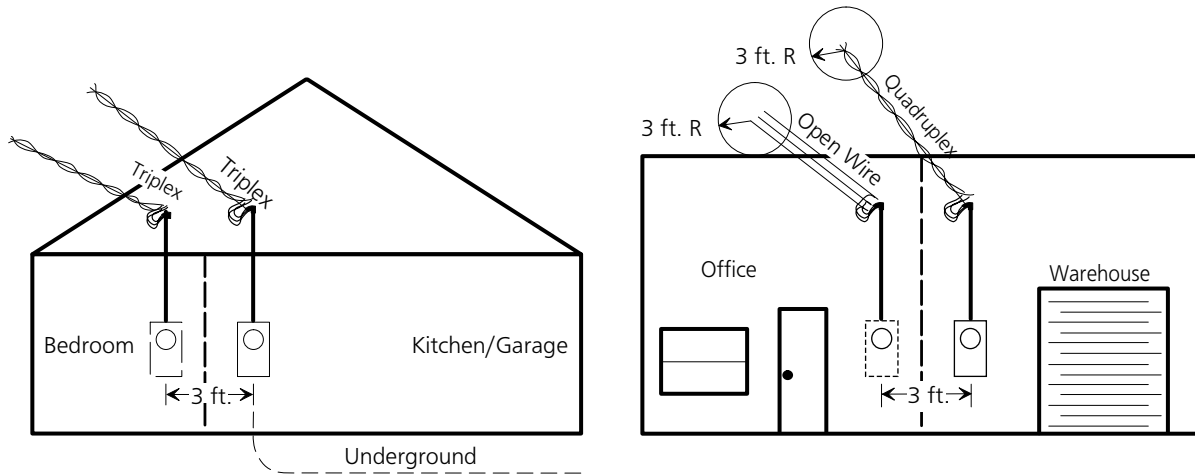

Moving Meter Panel 3 feet will reduce EMF approximately 87 percent.

Example:

100 Amps at 1 ft.; Maximum B = 96 mG.

100 Amps at 3 ft.; Maximum B = 12 mG.

Moving Meter Panel 3 feet will reduce EMF approximately 88 percent.

Example:

250 Amps at 1 ft.; Maximum B = 128 mG.

250 Amps at 3 ft.; Maximum B = 15 mG.

^{2/} These methods are also in minimizing the effects of magnetic fields on sensitive electronic equipment, such as video display terminals.

ESR-1	General Information	REFERENCE NO. <i>PhH</i>
PAGE 1-26	Electrical Service Requirements ▶ SCE Public ◀	EFFECTIVE DATE 7-30-2004

Figure 1-3: Magnetic Field Strength Measurements 1Ø PM Transformer

**EMF: 1Ø 50 kVA PADMOUNT TRANSFORMER
7.2A Primary, 216A Secondary**

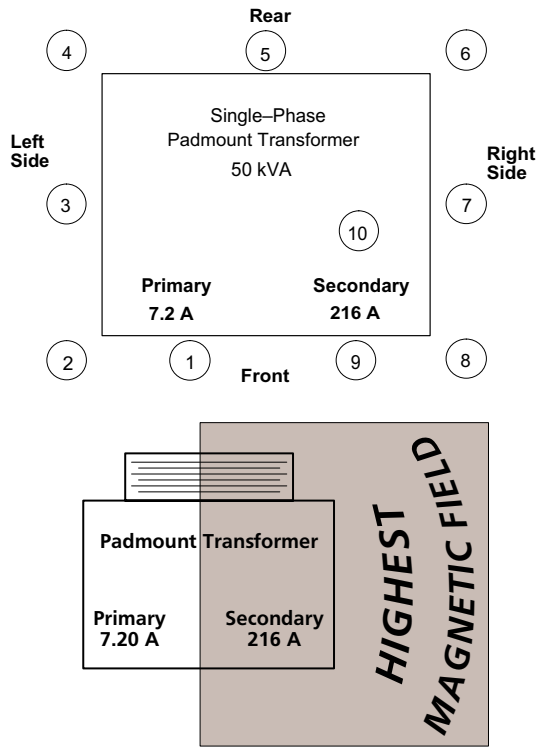

Maximum B (mG)

Location	Distance from Cabinet (inches)			
	1 inch	12 inches	36 inches	60 inches
1	59	7	6	4
2	29	10	4	4
3	68	26	6	5
4	27	12	7	5
5	56	24	4	3
6	63	10	5	4
7	380	94	15	7
8	97	28	5	4
9	220	54	11	5
10	590	101	14	5

14.6 Summary

EMF has not been established to have either worker or community health impacts, nor is there sufficient information available so set public health standards (i.e. because a health hazard has not been established, and there is no operational definition of exposure). Edison wants the electric utility industry and the community to take appropriate actions in preparation for an uncertain future. While these actions may or may not have any actual public health benefits, they are justified as long as the costs are reasonable, they do not adversely affect electric system reliability, safety, or cost impacts, and do not impact the appropriate allocation of individual or social public health resources.

The guidelines presented here are for new construction and are examples of the most common situations that Edison, architects and developers face where they may make an impact on EMF exposure. Edison has an EMF Education Center and Specialists available at (800) 200-4SCE if additional information is required.

15.0 Residential Area Installations

Residential developers building in hazardous areas that contain a concentration of flammable vapors or gases will be required to install a seal at the underground service termination enclosure that complies with the National Electric Code (NEC).

REFERENCE NO. <i>PHH</i>	General Information	ESR-1
EFFECTIVE DATE 7-30-2004	Electrical Service Requirements ▶ SCE Public ◀	PAGE 1-27

15.1 Hazardous Areas by Class and Division

The following general definitions are derived from the National Electric Code:

- A. Class 1, Division 1: Locations in which ignitable concentrations of flammable vapors or gases may be present under normal operation conditions - highly hazardous.
- B. Class 1, Division 2: Locations in which flammable liquids, vapors or gases are handled, processed or used but are normally confined within closed containers or systems.

15.2 Location of Service Facilities

Service and metering facilities (i.e., approved underground terminating enclosures and metering sections) shall be located outside classified hazardous locations (as defined above) unless the Company determines it is not possible.

The Company does not use or install duct sealing devices or compounds (e.g., sealing hubs, fittings, and associated sealing compounds) that are intended to prevent the transfer of hazardous or explosive gases into underground service terminating enclosures (e.g., pull boxes or pull sections) or into service conduits to those enclosures. If at all possible, the underground service shall be designed so that such devices are not required.

If the service conduits should extend through a hazardous location, the terminating enclosure shall be located outside of the building (not in a meter room) and outside of the hazardous area.

15.3 EYS Vertical Conduit Seal Fitting and Material Application

The customer is responsible for properly selecting and installing the sealing materials in the EYS vertical conduit seal fitting after the Company has installed the service cable. The sealing materials (sealing compound and fiber dam) shall be the type approved for the conditions and use. The vertical conduit seal fitting and sealing compound application provides a seal against the passage of gases or vapors, which complies with Article 501 in the NEC.

15.4 Service Cable Replacement

Should the service cable require replacement, the Company shall be notified to de-energize the service cable. The customer (at their expense) shall be responsible to cut out the existing vertical conduit sealing fitting along with the service cable in the fitting.

Before the new EYS vertical sealing fitting is installed by the customer (at their expense), the customer should contact the local authority having jurisdiction to verify if the vertical sealing fitting is still required to prevent the transfer of hazardous gases or vapors. If it is determined that the fitting be required, the customer shall install the new vertical conduit sealing fitting and mandrel the conduit to clear any obstruction in the conduit and provide a pull rope in the conduit before the Company installs new service cable.

After the Company installs the new service cable, the customer (at their expense) shall apply the fiber dam and sealing compound. The local authority having jurisdiction shall re-inspect the application.

Should the local authority having jurisdiction determine that the vertical conduit sealing fitting and sealing materials are not required, the customer (at their expense) shall install Schedule 40 PVC conduit where the fitting was cut out to the terminating pull section of the meter panel. The customer shall provide a pull rope in the conduit before the Company installs new service cable.

ESR-1	General Information	REFERENCE NO. <i>PhH</i>
PAGE 1-28	Electrical Service Requirements ▶ SCE Public ◀	EFFECTIVE DATE 7-30-2004

Figure 1-4: EYS Vertical Conduit Seal

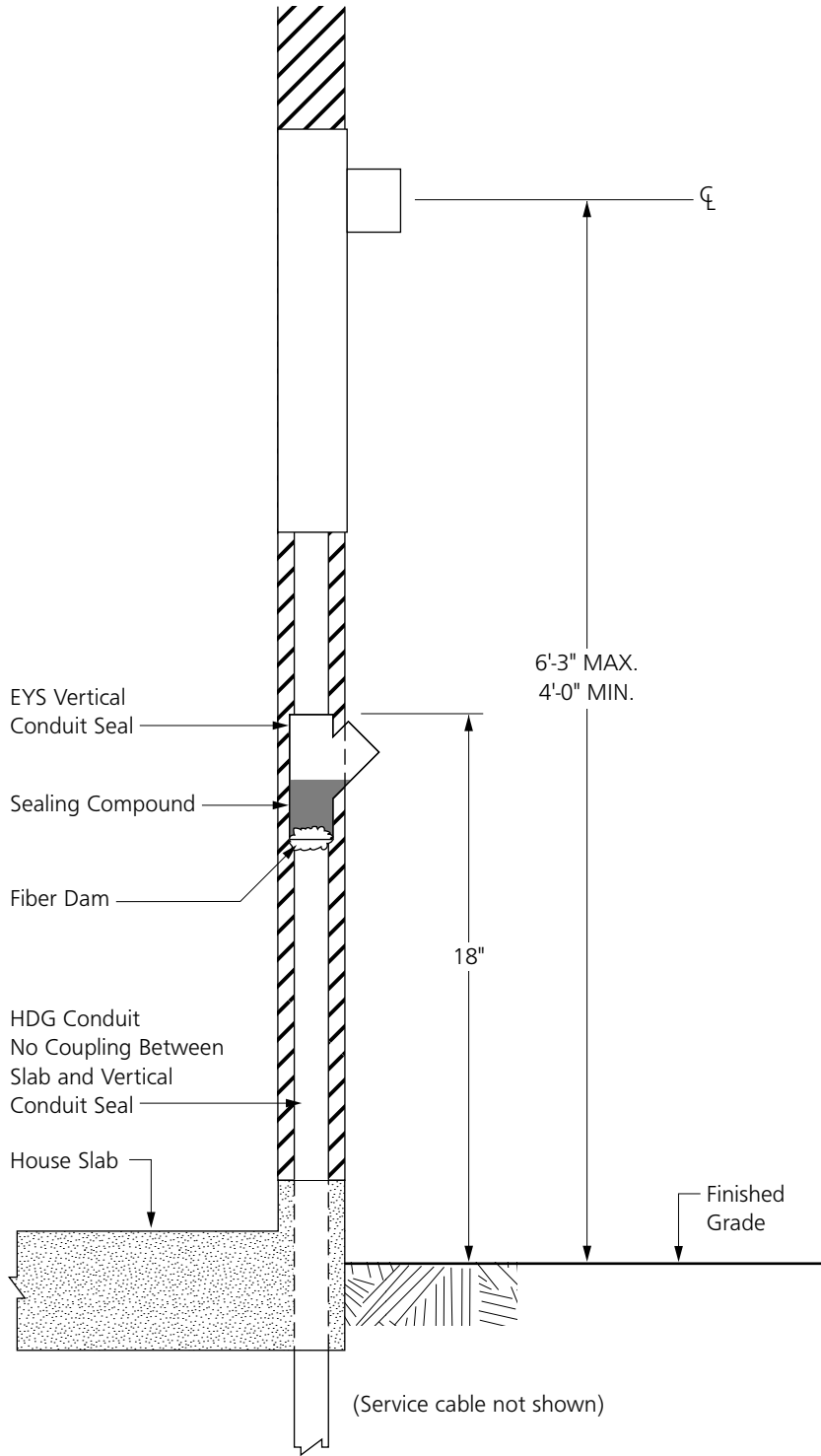

REFERENCE NO. <i>PhH</i>	General Information	ESR-1
EFFECTIVE DATE 7-30-2004	Electrical Service Requirements ▶ SCE Public ◀	PAGE 1-29

OVERHEAD SERVICE
CONNECTIONS
0-600 VOLTS

ESR-2

ESR-2

**OVERHEAD SERVICE
CONNECTIONS
0-600 VOLTS**

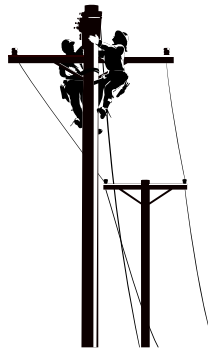

TDBU
▶ **SCE Public** ◀



**SOUTHERN CALIFORNIA EDISON
TDBU**

ESR-2: Overhead Service Connections 0-600 Volts

TABLE OF CONTENTS

Section No.	Title	Page
1.0	Overhead Service General Information	2-4
2.0	Combination Loads.	2-4
2.1	Single-Phase Service — 120/208, 120/240, 240, and 240/480 Volts	2-4
2.2	Three-Phase Four-Wire Service.	2-4
2.3	Three-Phase Four-Wire 120/208 Volt Wye Service	2-4
2.4	Three-Phase Four-Wire 277/480 Volt Wye Service	2-4
2.5	Three-Phase Four-Wire 120/240 Volt Delta Service	2-4
2.6	Three-Phase Service—120/208, 240, and 277/480 Volts	2-5
3.0	Service Drops	2-5
3.1	General	2-5
3.2	Single Point of Service Delivery Per Building.	2-5
3.3	Point of Service Delivery - Two or More Buildings on the Same Lot or Premises	2-6
3.4	Number of Service Drops at One Point of Service Delivery	2-6
3.5	Maximum Length	2-6
3.6	Service Drop Termination on the Customer's Structure	2-7
3.7	Height of Point of Service Drop Attachment on the Customer's Structure	2-7
4.0	Service Drop Supports	2-7
4.1	General	2-7
4.2	Wood Buildings	2-8
4.3	Residential Buildings	2-8
4.4	Other Than Wood Buildings	2-8
4.5	Horizontal Timbers	2-8
4.6	Vertical Risers	2-8
5.0	Location of Service Drop Supports or Point of Building Attachment	2-9
5.1	General Requirements	2-9
5.2	Specific Requirements.	2-10
5.3	Exceptions	2-10
6.0	Service Heads.	2-11
6.1	General	2-11

APPROVED 	Overhead Service Connections 0-600 Volts	ESR-2
EFFECTIVE DATE 5-10-2002	Electrical Service Requirements ▶ SCE Public ◀	PAGE 2-1

TABLE OF CONTENTS

Section No.	Title	Page
6.2	Maximum Number of Service Heads - Parallel Service Entrances.	2-11
6.3	Location of Service Head	2-11
6.4	Height of Service Heads	2-11
7.0	Service Entrance Conductors and Raceways	2-12
7.1	General	2-12
7.2	Service Entrance Conductors.	2-12
7.3	Service Entrance Raceways	2-12
7.4	Service Entrance Cable	2-13
7.5	Swimming Pool Clearances	2-24
7.6	Minimum Allowable Clearances for Services Drops	2-25
8.0	Customer Owned Service and Meter Poles	2-26
8.1	General Requirements for Permanent and Temporary Service 0-600 Volts.	2-26
8.2	Wood Brace for Temporary Service Requirements One Year or Less: Requirements in Figure 2-14 (page 2-30).	2-28
9.0	High Voltage Connections 2,400, 4,160, 4,800, 7,200, 12,000, 16,500 & 33,000 Volts.	2-33
9.1	General	2-33
9.2	Service	2-33
9.3	Single Phase Service Capacity	2-33
9.4	Three Phase Service Capacity	2-33
9.5	Single point of Service Delivery	2-34
9.6	Service Support – Customer’s Service Pole	2-34

LIST OF TABLES

Table No.	Title	Page
2-1	Timber Risers	2-9
2-2	Minimum Allowable Vertical Clearance Over Buildings and Structures 0-600 Volt Service Drops, Residential	2-25
2-3	Minimum Service Cable Clearance Above Ground	2-25
2-4	Vertical Clearances Above Railroads, Thoroughfares and Ground (G.O. 95 Table – 1).	2-26

ESR-2	Overhead Service Connections 0-600 Volts	APPROVED 
PAGE 2-2	Electrical Service Requirements ▶ SCE Public ◀	EFFECTIVE DATE 5-10-2002

LIST OF FIGURES

Figure No.	Title	Page
2-1	Overhead Service Connections on Commercial & Industrial Buildings	2-14
2-2	Overhead Service Connections on Residential Building.	2-15
2-3	Methods of Attaching Service Drops to Buildings	2-16
2-4	Solid Wood Service Drop Attachment Risers	2-17
2-5	Conduit Service Drop Attachment Risers (Periscope Type)	2-18
2-6	Service Drop Clearance – Residential Premises	2-19
2-7	Clearance of 0–600 Volt Services from Doors, Exits, Windows, Fire Escapes.	2-20
2-8	Minimum Vertical Clearance of Service Drops—Industrial or Commercial	2-21
2-9	Service Drop Clearance – Commercial or Industrial Premises	2-22
2-10	Clearance of Timber Risers on Buildings	2-23
2-11	Swimming Pool Clearances	2-24
2-12	Pitch of Roof	2-25
2-13	Temporary Service Requirements (Service for One Year or Less).	2-29
2-14	Wood Brace for Temporary Service Requirements (Service for One year or Less).	2-30
2-15	Customer Owned Permanent or Temporary Service Pole	2-31
2-16	Optional Customer Owned Service and Meter Pole	2-32
2-17	Busway Service Head Requirements 3Ø 4-Wire Wye or Delta, 600V Maximum.	2-35

APPROVED 	Overhead Service Connections 0–600 Volts	ESR–2
EFFECTIVE DATE 5-10-2002	Electrical Service Requirements ▶ SCE Public ◀	PAGE 2–3

1.0 Overhead Service General Information

Overhead service is not available in Underground designated locations. Overhead service will not be supplied to any building or premises in an area designated as underground facilities only by the Company or local jurisdiction. In areas where both overhead and underground service facilities exist, the Company shall be consulted for determination of the type of service which will be supplied.

2.0 Combination Loads

Consult the Company for proper rate and meter location. Refer to for service voltage grounding.

2.1 Single-Phase Service – 120/208, 120/240, 240, and 240/480 Volts

The maximum rating of an individual meter switch for 120/208 volt, three-wire service is 200 amperes. Normally for 120/240 or 240-volt service, the maximum meter switch rating is 400 amperes. Under certain operating conditions, permission may be granted for installation of 600 amperes service equipment for an individual 120/240 or 240-volt load. Otherwise, two separate 400 amperes service installations, or three such installations of 400 amperes or more, may be required, and totalized metering will normally be available. Consult the local Service Center for requirements.

On multiple occupancy buildings consult the local Service Center office for load requirements. Refer to [ESR-5: Section 6.0 "Meter Locations"](#) and [ESR-5: Table 5-1 "Meter Location per Type of Occupancy"](#) for group metering requirements.

2.2 Three-Phase Four-Wire Service

Service will only be supplied to a residence if three phase facilities are available at the location or there is one motor of more than 10 horsepower.

2.3 Three-Phase Four-Wire 120/208 Volt Wye Service

Service may be supplied at 120/208 volts wye provided the Company maintains a four-wire 120/208 volt wye system, or the customer's load would require an individual transformer installation of not less than 15 kVA; and, the transformer installation will be located on the customer's premises, when in the opinion of the Company such space is considered necessary.

2.4 Three-Phase Four-Wire 277/480 Volt Wye Service

Service will be supplied at 277/480 volts wye. The transformer installation will be located on the customer's premises, when in the opinion of the Company, such space is considered necessary.

2.5 Three-Phase Four-Wire 120/240 Volt Delta Service

Service may be supplied at 120/240 volt three-phase four wire delta provided the Company maintains a four-wire delta secondary system; or the installation requires not less than 15 kVA of transformer capacity; the unbalance between phases is less than 100 kW, and the service transformers will be located on the customer's premises, when in the opinion of the Company such space is considered necessary.

ESR-2	Overhead Service Connections 0-600 Volts	APPROVED <i>PhH</i>
PAGE 2-4	Electrical Service Requirements ▶ SCE Public ◀	EFFECTIVE DATE 5-10-2002

2.6 Three-Phase Service—120/208, 240, and 277/480 Volts

Normally, for a given voltage or phase, only one set of service entrance conductors with one meter switch which carries a customer's entire load will be permitted to a single occupancy. In all cases, the Company shall be consulted relative to available voltage and method of service delivery prior to making the service wiring installation. The maximum capacity for 120/208, 240, or 277/480 volts three-phase is 4,000 amps of connected load. When capacity exceeding 4,000 amperes is required, two or more services may be installed with totalized metering, see [ESR-6: Section 5.0 "Totalized Services"](#).

3.0 Service Drops

3.1 General

Upon a bona fide application for service, and where the Company's distribution pole line is located on the customer's premises, or on a street, highway, lane, alley, road, or private easement immediately contiguous thereto, the Company will, furnish and install a single span of service drop wires from its pole to the customer's first approved permanent support.

Customer service drop supports shall be of a type and so located that Company service wires may be installed in accordance with good engineering practice, Company requirements, and all applicable laws, ordinances, rules, and regulations, including those governing clearances and points of attachment. Proper service drop support locations must be approved and verified by the local Service Center office. The Company is not responsible for a service drop support location assumed by the contractor or the customer.

When service drop clearances become impaired because of changes created by the tenant or owner of a premises; including such items as patio covers, fireplace chimneys, satellite dish, desert coolers, or swimming pools; See [Section 7.5 "Swimming Pool Clearances" \(page 2-24\)](#), it is incumbent upon the customer at their expense, to provide a means to correct the infraction.

When the installation of a new building or structure conflicts with the location of the existing utility service drop on the property serviced or existing Customer service entrance conductors, it shall be the responsibility of the party making the new installation to clear the conflict.

3.2 Single Point of Service Delivery Per Building

For all single-phase and three-phase installations where the individual meter switches are rated 200 amperes and below, only one point of service delivery will be established for a single or multiple occupancy building (including condominiums in common tenancy and townhouses developed with common area), unless otherwise determined by reason of Company operating necessity. All service heads, together with the required facilities for termination of the Company's service drops for each of the phase and voltage classes of load to be served, shall be as closely grouped at this location as practicable. Consult the local Service Center office for requirements. See [Section 6.0 "Service Heads" \(page 2-11\)](#) for service head requirements and [ESR-5: Section 6.0 "Meter Locations"](#) and [ESR-5: Table 5-1 "Meter Location per Type of Occupancy"](#) for group metering requirements.^{1/}

1/ For townhouse developments where commonly owned property is not available, individual services may be provided to each townhouse unit.

APPROVED 	Overhead Service Connections 0-600 Volts	ESR-2
EFFECTIVE DATE 5-10-2002	Electrical Service Requirements ▶ SCE Public ◀	PAGE 2-5

3.3 Point of Service Delivery - Two or More Buildings on the Same Lot or Premises

Two or more buildings on the same lot or continuous premises may each have a point of service delivery under the following conditions:

- A. Local ordinances permit such installations.
- B. Each point of service delivery is so located that the service drop may be installed from the distribution pole line serving the lot or premises in accordance with all applicable clearances, distances and requirements of the Company.
- C. In cases where single premises are abnormally extensive in area, the Company shall be consulted with respect to the method by which service will be supplied.^{2/}

3.4 Number of Service Drops at One Point of Service Delivery

Not more than one set of service drops will be installed by the Company to any one point of service delivery as permitted in [Section 3.2](#) hereof, for any single or multiple occupancy building for the same voltage and phase classification, except as follows:

- A. Where for single phase load only, with service delivery at 120/240 volts, the total load to be served employs sets of service entrance conductors supplying groups of meter switches, main service switches, or meter switches supplied by individual sets of service entrance conductors, with aggregate capacity exceeding the maximum capacity which will be supplied by one set of service drops as specified in the [Section 2.0 "Combination Loads" \(page 2-4\)](#), the contractor shall install two or three separate sets of service entrance conductors as required thereon for the total load, and provide service terminating facilities for a separate service drop near each service head required.
- B. For 240 volt single phase power loads the Company shall be consulted in each case relative to the required serving method. These loads may in some cases be supplied by one three-phase service drop. In any case, a separate set of service entrance conductors for connection to a separate service drop may be required by reason of the Company's operating necessity.

3.5 Maximum Length

The maximum length of a service drop is typically 100 feet but may vary depending upon the slope or grade of the land, intervening trees or structures, the size of conductors used, and the height and strength of the customer's service drop support. In order to minimize the strain, the point of service drop termination on the building shall be located as near to the Company's serving pole as practicable. Where questionable or extraordinary conditions exist, the Company Service Center office shall be consulted prior to the establishment of a point of service delivery.

^{2/} Multiple occupancy buildings will be served by one point of service delivery unless otherwise determined by reason of Company operating necessity. Refer to [ESR-5: Section 6.0 "Meter Locations"](#) and [ESR-5: Table 5-1 "Meter Location per Type of Occupancy"](#) for group metering requirements.

ESR-2	Overhead Service Connections 0-600 Volts	APPROVED <i>PhH</i>
PAGE 2-6	Electrical Service Requirements ▶ SCE Public ◀	EFFECTIVE DATE 5-10-2002

3.6 Service Drop Termination on the Customer's Structure

The contractor shall provide a suitable landing at the point of service delivery adjacent to the service head which will permit the attachment of service drop conductors in a manner acceptable to the Company. This service drop support, together with its supporting building or structure shall have adequate strength to safely withstand the strain of the service drops. Where an unusually heavy service is involved the Company Service Center office shall be consulted with respect to the service drop support. Where the building does not provide sufficient strength to comply with requirements, the contractor shall install an adequate service pole adjacent to the building.

The Company will furnish and install only its standard service knobs, insulators, brackets or racks. Any special devices or structures when permitted or required shall be furnished and installed by the contractor, conform to all legal requirements and be acceptable to the Company.

3.7 Height of Point of Service Drop Attachment on the Customer's Structure

The height of the point of support or attachment of service drop conductors on the customer's structure shall be adequate to provide vertical clearances between service drop conductors and the ground, structures, roofs, stairways, windows, etc., not less than the values given in the text, [Table 2-2](#) and [Table 2-3 \(page 2-25\)](#), [Table 2-4 \(page 2-26\)](#) and illustrations in [Figure 2-6 \(page 2-19\)](#) through [Figure 2-9 \(page 2-22\)](#). Adequate allowance must be made for the lowest point of sag in the service drop conductors and for the grade or slope of the area over which they pass.

4.0 Service Drop Supports

4.1 General

Only power service drops shall be permitted to be attached to a service mast or riser per NEC Section 230-28. Only one service drop supporting structure may be installed for a service drop. It shall be located at the point of service delivery and normally will support the service head.

A service drop supporting structure may consist of a timber, angle iron or pipe rack, or a single unspliced timber or equivalent steel pipe or member. All types shall be securely braced where necessary and shall be bolted or lagged to the frame or to equally substantial members of the building. Where service entrance conductors exceeding 500 KCMIL AWG are to be installed, the Company Service Center office shall be consulted prior to erection of the structure.

In each case where a metallic structure is proposed, the contractor shall ascertain from the Company the proper number, size and configuration of the holes necessary to accommodate the studs or bolts furnished by the Company, to secure its service knobs or insulators to the structure. The contractor shall drill, and where necessary, tap such holes as designated by the Company.

APPROVED 	Overhead Service Connections 0-600 Volts	ESR-2
EFFECTIVE DATE 5-10-2002	Electrical Service Requirements ▶ SCE Public ◀	PAGE 2-7

4.2 Wood Buildings

Where properly located exposed surfaces of substantial wood building members are available which provide adequate strength and not less than 2 inches nominal thickness, service knobs will be screwed thereto. Where such surfaces are concealed by plaster or similar material the contractor shall prior to the application of such material, either install the necessary knobs or bolts, (both of which will be furnished by the Company) for the attachment of insulators, brackets, or racks, or shall provide visible external evidence of the location of the concealed studs or timbers by properly placing large nails which project out of the finished plaster or other surface material.

4.3 Residential Buildings

On residential buildings only, service drops of 0–300 volts will, where better facilities are not available, be attached to rafters or suitable timbers from the upper side of a non-metallic roof only; provided that the rafters are exposed outside the wall plate and the roof surface is suitable. Attachment to a roof will in no case be made back of the outer face of the wall or wall plate, or above any enclosed cornice. See [Figure 2–3 \(page 2–16\)](#).

4.4 Other Than Wood Buildings

Where service drops are to be terminated on a building or structure on any portion thereof composed of metal, masonry, brick stone, concrete, concrete blocks, or similar materials, the Company will furnish to the contractor at his request, any bolts necessary for the attachment of the Company's service drop dead ending insulators or devices. Bolts will not be furnished for construction of supporting structures or their attachment to the building. The contractor shall install the bolts in the proper location which, where necessary, will be designated by the Company.

Overhead service will not be rendered directly to wind machine towers or columns, or similar equipment subject to excessive vibration. Unless the meter box is installed on a separate vibration free structure, the service conduit, if attached to the structure, shall descend into the concrete base and rise up into the meter structure.

4.5 Horizontal Timbers

Suitable horizontal timbers shall have minimum nominal size of 3" x 4" x 30" and shall be bolted or lagged to the frame or other equally substantial portion of the building. Metal members may be installed in lieu of wood if drilled as specified by the Company. Timbers fastened on continuous wood surfaces may be 2" x 4" minimum. Consideration should be given to permit attachment of telephone and CATV drops (at required clearances) in addition to the electrical supply service drop.

4.6 Vertical Risers

Where any type of vertical riser is installed on a building having brick, concrete block, adobe or similar walls, particular care shall be exercised to ascertain that its attachment will be made so that the wall will safely withstand the strain imposed thereon by the riser.

A. Timber Risers

ESR–2	Overhead Service Connections 0–600 Volts	APPROVED <i>PhH</i>
PAGE 2–8	Electrical Service Requirements ▶ SCE Public ◀	EFFECTIVE DATE 5-10-2002

Table 2-1 specifies minimum requirements for determining the dimensions of unbraced or braced single solid timber risers to support service drops of varying length based upon the maximum size of service entrance conductors involved. See Illustrations Figure 2-10 (page 2-23). For method of installation see Figure 2-4 (page 2-17).

Table 2-1: Timber Risers

Dimensions of Single Riser - Clear Douglas Fir Solid Timber	Height of Point of Attachment Above Building	Allowable Length of Service Drop in Feet	Maximum AWG Size of Conductor Involved in Service Entrance
4" x 4" Unbraced	5 feet or less	0 to 75	#1
4" x 6" Unbraced	5 feet or less	75 to 100	#1
4" x 6" Unbraced	5 feet or less	0 to 75	500 KCMIL
4" x 6" Unbraced	5 to 8 feet	0 to 75	#1
4" x 6" Braced	Over 5 feet	0 to 75	500 KCMIL
6" x 6" Unbraced	8 to 12 feet	0 to 75	Consult Company

Where a 4" x 6" timber is installed it shall be placed with the 6 inch dimension in the general direction of pull of the service drop.

B. Conduit Risers (Periscope Type)

A conduit riser of the periscope type may be installed as a service drop support where permitted, provided that the installation is made in accordance with the requirements of Figure 2-5 (page 2-18). The Company will not assume any liability for damage to the building caused by roof leakage around such risers or from mechanical failure of the riser, its attachments to the building, or failure of any part of the building.

5.0 Location of Service Drop Supports or Point of Building Attachment

5.1 General Requirements

The point of attachment on the building or structure shall be located to permit the service drops to be run in a manner acceptable to the Company, unobstructed and free from interference from poles, flood lights, antenna masts, vent pipes, trees etc. and so that clearances not less than those indicated in the text, Table 2-2 and, Table 2-3 (page 2-25), Table 2-4 (page 2-26) and illustrations in Figure 2-4 (page 2-17) through Figure 2-11 (page 2-24) will be maintained between the drops and the ground, structures, roofs, stairways, balconies, walkways, windows, pools, etc.

The location must be such that the service drop will not cross adjoining premises.

The location must be such that consumers yard wiring will not be less than 3 feet radially from the service or open service entrance conductors.

These location requirements shall apply whenever existing service installations are upgraded.

Contact the Company local Service Center office to verify the location of service drop supports and points of attachment. When service equipment is improperly located because the Company was not contacted in advance, the customer is responsible for all modifications.

APPROVED 	Overhead Service Connections 0-600 Volts	ESR-2
EFFECTIVE DATE 5-10-2002	Electrical Service Requirements ▶ SCE Public ◀	PAGE 2-9

5.2 Specific Requirements

The service drop support or point of attachment shall be located on that exterior wall, exterior frame member, roof edge or verge on the side of the building or structure which is nearest the street, alley, public way or easement occupied by the Company's distribution pole or U.G. distribution system from which service will be supplied. See [Figure 2-1 \(page 2-14\)](#) for commercial and industrial buildings and [Figure 2-2 \(page 2-15\)](#) for residential buildings.

The location shall be such that the service drops will not pass over any portion of the building served except small incidental roofs, balconies, walkways, stairways, fire escapes and other similar minor projections from the wall or frame on which the drops are terminated.

5.3 Exceptions

Where the service drops from the Company's pole will pass over only the premises served; and will cross no intervening part of the building served; and, will conform to all other provisions of these requirements; the service drop support or point of attachment may, where permitted by local ordinances, be on any exterior wall, exterior frame member, roof edge or verge provided that any increase in service drop length is acceptable to the Company. See [Figure 2-1 \(page 2-14\)](#) and [Figure 2-2 \(page 2-15\)](#).

Where the nearest exterior wall to the Company's distribution pole line is a shed or similar attachment to the building and does not afford sufficient height for a service drop support without erection of a vertical extension, and there is another wall or building member of adequate height and facing likewise; the point of service drop attachment may, where permitted by local ordinance, be located on this wall or member, provided that the service drops will in no case pass over the low shed type attached part of the building for a distance of over 30 feet. The point of attachment shall be located so that the vertical clearance between the service drops and the portion of the building passed over will be the maximum practicable, and in no case less than the vertical clearances shown in [Figure 2-9 \(page 2-22\)](#) for commercial and industrial premises or in [Table 2-2 \(page 2-25\)](#) for residential premises.

For residential service drops of 0-300 volts the point of building attachment shall not be less than one foot above any non-metallic roof or similar surface and shall be located so that the service drops will, beyond 10 feet from the point of attachment have a vertical clearance from the building served of not less than 2 feet. See [Table 2-2 \(page 2-25\)](#) for clearances over metallic roofs. See also "Exhibit B" in [Figure 2-2 \(page 2-15\)](#).

The point of attachment for residential service drops may be on the upper side of non-metallic roof eaves. See [Section 4.3 "Residential Buildings" \(page 2-8\)](#).

For residential service drops of 0-300 volts the point of attachment may be located so that the service drops will extend the minimum practicable distance beyond the building wall facing the pole line and will not extend more than 1/2 the depth of the building, or extend past the highest part of the section to which they are attached. In such cases the point of attachment to the building shall be located so that at least 2 feet vertical clearance will be maintained between the service drop and any incidental non-metallic roof of the building served. A clearance of 8 feet is required over metallic roofs of 3/8 pitch or less. See [Table 2-2 \(page 2-25\)](#).

ESR-2	Overhead Service Connections 0-600 Volts	APPROVED <i>PhH</i>
PAGE 2-10	Electrical Service Requirements ▶ SCE Public ◀	EFFECTIVE DATE 5-10-2002

6.0 Service Heads

6.1 General

For overhead services, an adequate service head shall be provided on the supply end of every service enclosure or service entrance cable.

6.2 Maximum Number of Service Heads - Parallel Service Entrances

When more than three overhead service entrance conductors paralleled per phase are in 3 separate risers necessary to supply the load for one metering location a bus-way type service entrance shall be required. See [Figure 2-17 \(page 2-35\)](#).

For service requirements on busways installed for service from a transformer vault see [ESR-3: Section ESR-3: "Underground Service Connections 0-600 Volts"](#) and [ESR-4: Section ESR-4: "Company Owned Transformers on Customer's Premises"](#).

6.3 Location of Service Head

The service head shall be so located on the exterior of the structure served that only one point of attachment will be required for the service drop and should, where practicable, be at least one foot above the level of the required point of service drop attachment. The location shall be such that the service entrance conductors may be conveniently connected to the service drop. Adequate drip loops shall be formed in the open wires between the service head and the point of attachment to the service drop. These service entrance wires shall not exceed 3 feet in length.

Where more than one service head for the same phase and voltage class of service is installed on a building, all such service heads shall be located so that they may be supplied through a single service drop, except where the total single phase load requires installation of more than one service drop.

Where service heads for different phase and voltage classes of service are installed on a building on which a single point of delivery is established, such service heads shall be located as close together as practicable except as otherwise directed by the Company representative.

The service head may be located above the roof of the structure served provided its installation conforms to all applicable provisions of these Electrical Service Requirements and applicable local ordinances.

A service head shall not be located on any wall or building member which faces and is less than 3 feet from a common property line.

6.4 Height of Service Heads

The service head shall be installed at a height which will maintain the conductor clearances above the ground and objects or structures required by the governing laws, rules or ordinances, together with these requirements. The height shall not be less than 10 feet for services limited to 150 volts to ground, 12 feet for services limited to 300 volts to ground, or more than 30 feet above the exterior grade level nearest such service head.

APPROVED 	Overhead Service Connections 0-600 Volts	ESR-2
EFFECTIVE DATE 5-10-2002	Electrical Service Requirements ▶ SCE Public ◀	PAGE 2-11

7.0 Service Entrance Conductors and Raceways

7.1 General

For each overhead service connection the contractor shall furnish and install a set of service entrance conductors which shall conform with these requirements, and with the provisions of applicable local codes and ordinances.

7.2 Service Entrance Conductors

Service entrance conductors may be copper or aluminum. Where aluminum conductors are used, the following requirements apply:

- Terminals shall be approved for aluminum conductors. Aluminum - bodied, compression type terminals are preferred.
- Meter sockets shall be U.L. listed for use with aluminum conductors.
- Aluminum conductors shall be wire brushed and coated with an inhibitor compound before terminating.

The wire size shall not be less than No. 8 AWG Cu. or No. 6 AWG Al. and the wire shall have approved insulation, except that bare neutral conductors may be installed where permitted by the governing law, rule or ordinance.

Manufacturers using aluminum bus bar construction must use a plating process approved by EUSERC.

The conductors shall be continuous without tap or splice, except that approved clamped or bolted connections may be made in enclosures of metering equipment and taps to main service entrance conductors or to individual sets of metering equipment may be made in approved junction boxes, auxiliary gutters or meter troughs.

In cases where on commercial or industrial buildings, the service entrance conductors pass over the roof or firewall at a 12 inch minimum clearance, sufficient length of wire shall extend out of the service head (3 foot max.) to permit its connection to the Company's service drop by the Company so that the required 12" minimum clearance over the building will be obtained. See [Figure 2-8 \(page 2-21\)](#) and [Figure 2-9 \(page 2-22\)](#).

The Company shall make the connections between its service drop conductors and the supply end of the customers service entrance conductors.

Multiple sets of service entrance conductors wired in parallel shall not be installed within a single service mast or riser.

7.3 Service Entrance Raceways

No conductors except service entrance conductors shall be installed in the service raceway except where continuity bond wires are required by local inspection authorities. Where a main service switch or disconnecting means is installed on the supply side of a group of meters, the conductors on the line and load side of such disconnecting means shall be considered service entrance conductors.

Auxiliary gutters and meter troughs containing service entrance conductors are considered a part of the raceway. Only service entrance conductors may run from such enclosures to metering equipment. Conductors from the load side of a meter or meter switch shall not re-enter the service entrance raceway except in a separately barred section.

ESR-2	Overhead Service Connections 0-600 Volts	APPROVED <i>PhH</i>
PAGE 2-12	Electrical Service Requirements ▶ SCE Public ◀	EFFECTIVE DATE 5-10-2002

The main grounding connection from the grounding electrode or water pipe to the neutral conductor of the service may be made in an auxiliary gutter or meter trough where more than one meter is involved, provided the installation is made so as to minimize interference with equipment in the enclosure. Bonding conductors may be installed as required by inspection authorities.

7.4 Service Entrance Cable

Certain standard approved types of multiple conductor service entrance cable with conductors of not less than No. 8 AWG Cu. or #6 AWG Al., and approved service head with fittings may, be installed where permitted by inspection authorities.

If approved by the local inspection jurisdiction, service entrance cable could be installed on the exterior of the building. It may be installed concealed in wall spaces, but when so installed care shall be exercised to protect the cable against future mechanical injury and to allow for its replacement in case of failure.

Unless installed in continuous metal conduit, service entrance cable shall not be run through any roof, or be installed in or through any attic space, under floor space, basement or other space within the building, in any of which the cable will be accessible to persons, except where the accessible portion is in the same room with the meter and is readily visible.

Refer to the applicable drawings in **ESR-5: Section 11.0 "Grounding and Bonding"** through **ESR-5: Figure 5-35** for grounding requirements of inspection authorities.

APPROVED 	Overhead Service Connections 0-600 Volts	ESR-2
EFFECTIVE DATE 5-10-2002	Electrical Service Requirements ▶ SCE Public ◀	PAGE 2-13

Figure 2-1: Overhead Service Connections on Commercial & Industrial Buildings

Optional Points of Attachment of 0-600 Volt Service Drops

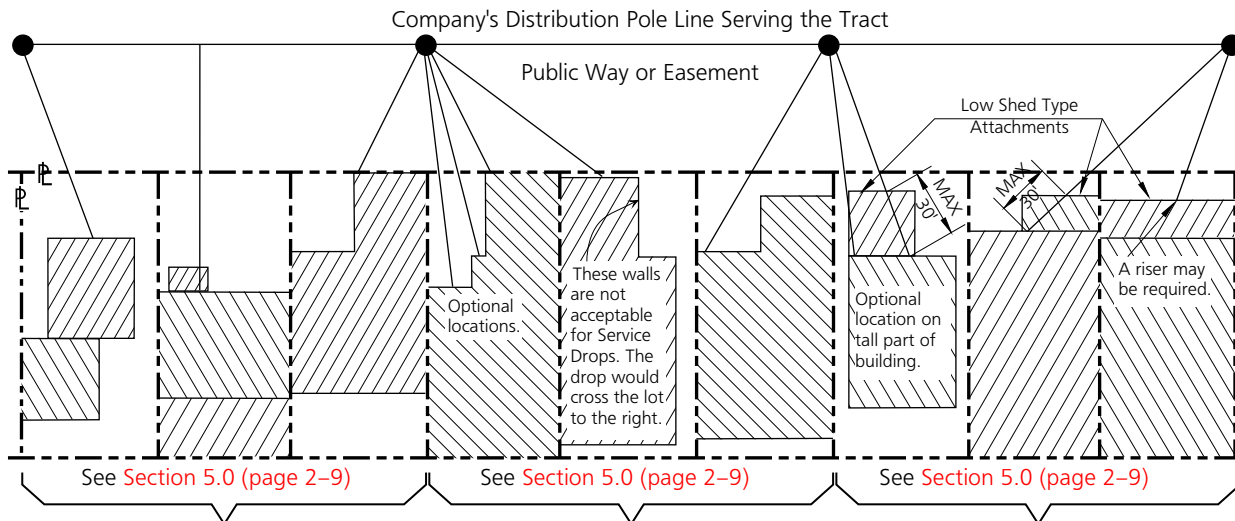

Nearest wall facing line. Drops passing over minor projections only.

On another wall. Drops crossing only the premises served.

Wall providing adequate height. Drops passing over low sheds which do not provide required ground clearance without a vertical structure.

Exhibit A

Exhibit B

Exhibit C

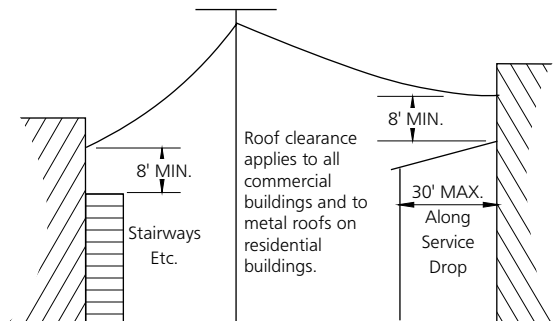

See Section 5.0 (page 2-9)

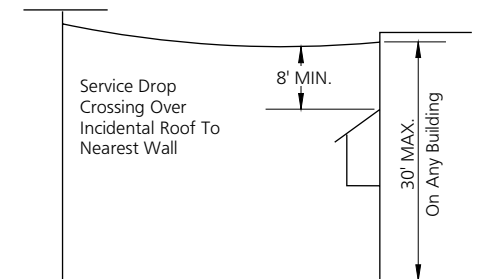

Maximum height of service drop attachment

Exhibit D

Exhibit E

Notes

1. The Company shall be consulted for information with respect to the proper location of the point of service delivery on a building.
2. Refer to **ESR-5: Section 6.1 "Meter Access"** and **ESR-5: Table 5-2 "Prohibited Meter Locations"** for meter access and prohibited meter locations.

ESR-2	Overhead Service Connections 0-600 Volts	APPROVED <i>PhH</i>
PAGE 2-14	Electrical Service Requirements ▶ SCE Public ◀	EFFECTIVE DATE 5-10-2002

Figure 2-2: Overhead Service Connections on Residential Building

Points of Attachment of 0-600 Volt Service Drops

The points of service drop attachment illustrated are acceptable only under the conditions specified in the text

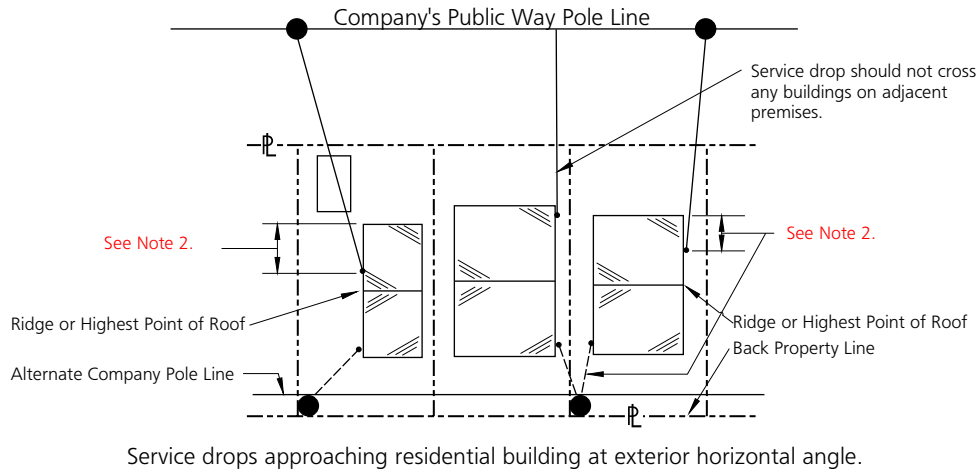

Exhibit A

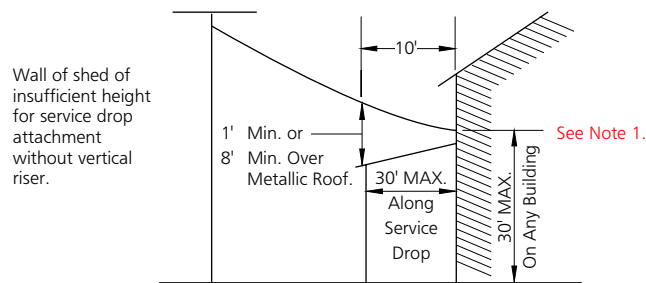

Exhibit B

Notes

1. The California Public Utilities Commission approves residential triplex services to be 12 inches or more above non-walkable metallic patio drops.
2. The service drop attachment to the building shall be the minimum practicable not more than one-half the depth of the building and not beyond highest point of roof.
3. Refer to **ESR-5: Section 6.1 "Meter Access"** and **ESR-5: Table 5-2 "Prohibited Meter Locations"** for meter access and prohibited meter locations.

APPROVED 	Overhead Service Connections 0-600 Volts	ESR-2
EFFECTIVE DATE 5-10-2002	Electrical Service Requirements ▶ SCE Public ◀	PAGE 2-15

Figure 2-3: Methods of Attaching Service Drops to Buildings

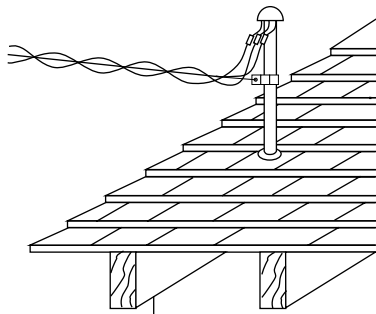

Exhibit A

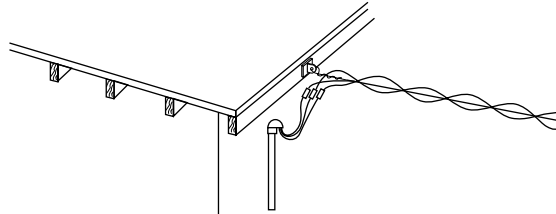

Exhibit B

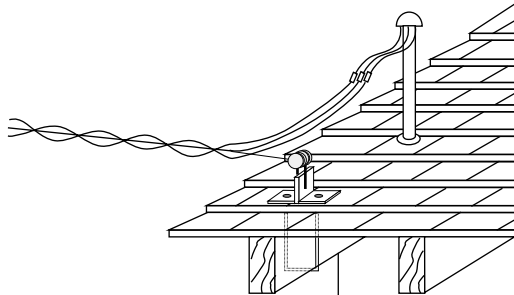

Exhibit C

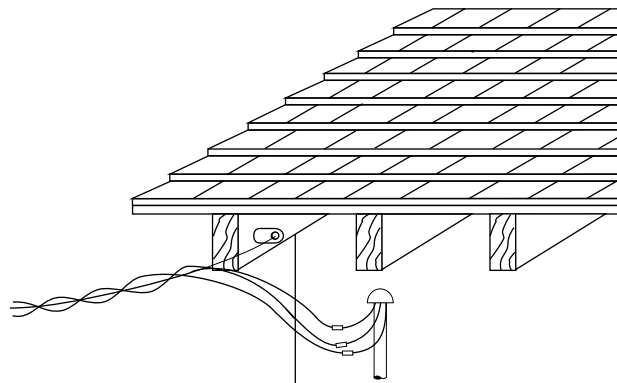

Exhibit D

Notes

1. All points of service drop attachment shall be on the wall, roof edge, verge or exterior frame member nearest and facing the company's pole line, except where other locations are permitted by these requirements.
2. The service head wherever practicable should be located one foot above the level of the point provided for service drop attachment. This arrangement is required by some inspection authorities.
3. For clearances see [Table 2-4 "Vertical Clearances Above Railroads, Thoroughfares and Ground \(G.O. 95 Table - 1\),"](#) (page 2-26), [Figure 2-6 "Service Drop Clearance - Residential Premises"](#) (page 2-19), [Table 2-2 "Minimum Allowable Vertical Clearance Over Buildings and Structures 0-600 Volt Service Drops, Residential,"](#) (page 2-25), [Figure 2-7 "Clearance of 0-600 Volt Services from Doors, Exits, Windows, Fire Escapes"](#) (page 2-20), [Figure 2-8 "Minimum Vertical Clearance of Service Drops-Industrial or Commercial"](#) (page 2-21), [Figure 2-9 "Service Drop Clearance - Commercial or Industrial Premises"](#) (page 2-22), and [Figure 2-10 "Clearance of Timber Risers on Buildings"](#) (page 2-23).
4. Drip loops shall be formed and connections shall be made below the service entrance weatherhead to prevent the entrance of moisture into the service conduit.

ESR-2	Overhead Service Connections 0-600 Volts	APPROVED <i>PhH</i>
PAGE 2-16	Electrical Service Requirements ▶ SCE Public ◀	EFFECTIVE DATE 5-10-2002

Figure 2-4: Solid Wood Service Drop Attachment Risers

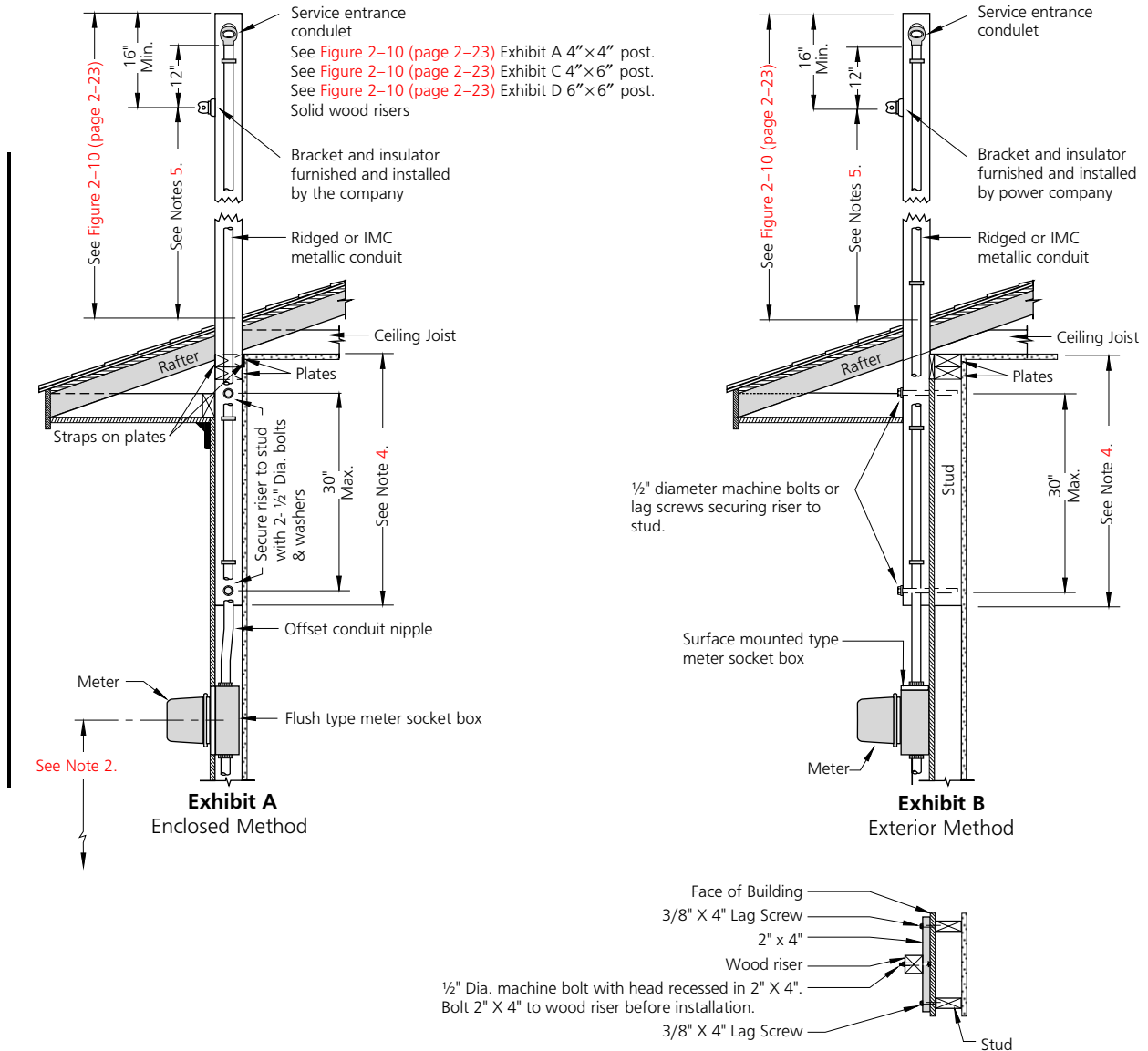

Notes

- None of these wood risers shall be spliced or of laminated construction (2 x 4's, 2 x 6's, etc.). Nailed or bolted together boards are not acceptable.
- The meter must be between the minimum of 4'-0" and 6'-3" maximum above grade. The height may be reduced to 3'-0" when the meter is enclosed in a meter closet.
- Service riser attachments in heavy snow loading areas shall have special construction. Contact the local company office.
- Where practicable the riser timber should extend below the building plate a distance equal to its projection above. But in no case less than 36 inches except where special provisions have been made for its anchorage.
- For clearances of 0-600 Volt service drops see Table 2-2 (page 2-25), and contact the local company office for details.
- The riser should be on or not more than 18 inches back of the front face of the wall facing the Company's line.
- Illustrations show buildings with slanting roofs. See Figure 2-9 (page 2-22) for clearance of service drops of 0-600 volts over flat roofed commercial buildings.

APPROVED <i>PhH</i>	Overhead Service Connections 0-600 Volts	ESR-2
EFFECTIVE DATE 5-10-2002	Electrical Service Requirements ► SCE Public ◀	PAGE 2-17

Figure 2-5: Conduit Service Drop Attachment Risers (Periscope Type)

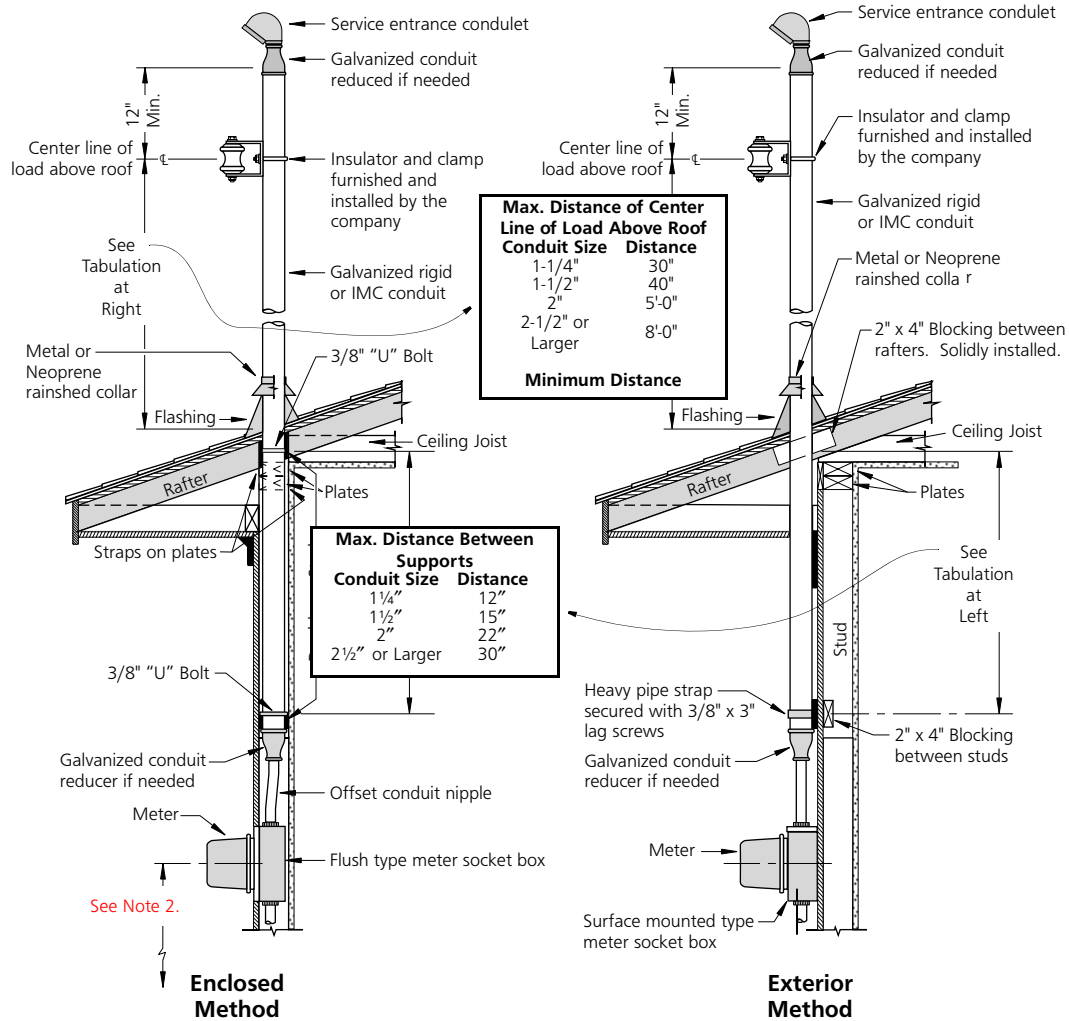

Notes

1. The above is a suggested method to obtain the required ground and roof clearances as required by California State General Order 95. When this method is used, it will be acceptable to the company provided the dimensions and construction details are complied with the dimensions shown and are based on a service drop length of not more than 100 feet. Any service length greater than 100 feet must be approved by the company.
2. The meter must be between the minimum of 4'-0" and 6'-3" maximum above grade. The height may be reduced to 3'-0" when the meter is enclosed in a meter closet.
3. The Company will not be responsible for any damage to the building caused by rain or structural failure.
4. The riser should be on or not more than 18 inches back of the front face of the wall facing the Company's line.
5. Install rigid steel or IMC conduit only for this application.
6. The minimum distance of centerline of load above roof is specific to each location. In all cases, this distance shall not be less than 12 inches minimum.
7. No couplings will be permitted between the top of the riser and the lowest point of support for conduit sizes 1-1/4 inches to 2 inches inclusive. If a coupling is necessary in 2-1/2 inches or larger conduit to secure the maximum height, the coupling shall be installed at the upper end near the service entrance conduit.

ESR-2	Overhead Service Connections 0-600 Volts	APPROVED <i>PhH</i>
PAGE 2-18	Electrical Service Requirements ▶ SCE Public ◀	EFFECTIVE DATE 5-10-2002

8. Only power service drop shall be permitted to be attached to a service mast or riser per N.E.C. Section 230-28.
9. The service riser attachments in heavy snow loading areas shall have special construction. Call the local Service Planning office for details.

Figure 2-6: Service Drop Clearance – Residential Premises

Services of 0-600 Volts
These Minimum Clearances Apply to the Lowest Point of Service Drop Sag.

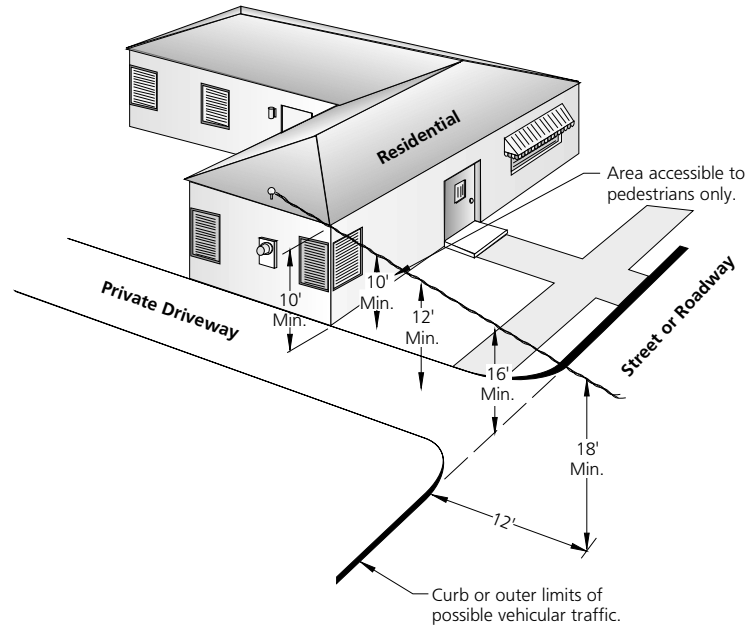

Notes

1. The radial clearance between supply service drop conductors and communications service drop conductors shall not be less than 24 inches. Where within 15 feet of the point of attachment of either service drop on a building, this clearance may be further reduced but shall not be less than 12 inches.
2. The Public Utilities Commission approves residential triplex services to be 12 inches or more above non-walkable metal patio roofs.
3. The service head shall in no case be less than 10 feet or more than 30 feet above the exterior grade level nearest such head.
4. Minimum clearances indicated are as required by the Rules for Overhead Line Construction of the California Public Utilities Commission (G.O. 95). The Commission has ruled that a 3 unit or larger apartment house is a commercial building and, therefore, requires commercial service clearances. Commercial clearances shall be provided over private or public driveways to 3 or more houses. For vertical clearances see [Table 2-4 \(page 2-26\)](#).
5. The point of service drop attachment on any riser shall in no case be more than 18 inches back of the front face of the wall facing the pole line to which the drops would be attached.

APPROVED <i>PhH</i>	Overhead Service Connections 0-600 Volts	ESR-2
EFFECTIVE DATE 5-10-2002	Electrical Service Requirements ▶ SCE Public ◀	PAGE 2-19

Figure 2-7: Clearance of 0-600 Volt Services from Doors, Exits, Windows, Fire Escapes

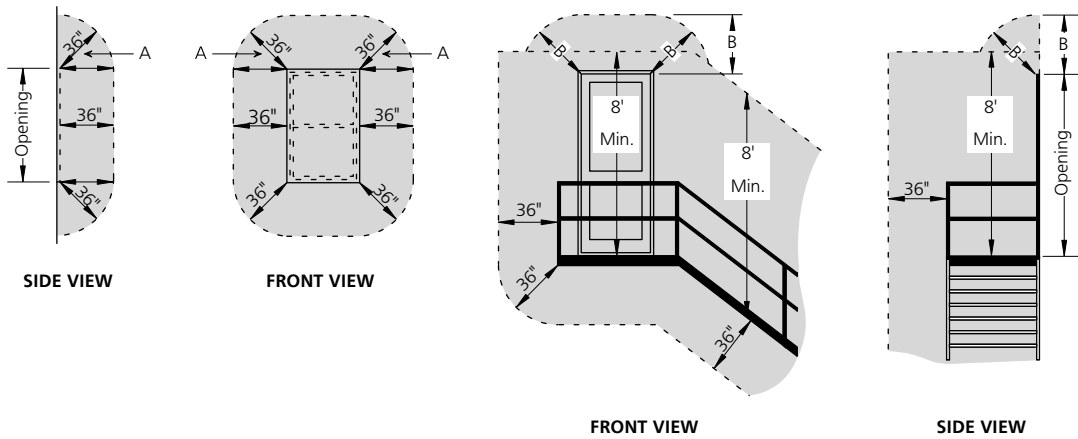

Notes

1. No supply service wires are permitted within the shaded area.
2. The Minimum clearances indicated comply with The Rules for Overhead Line Construction of The California Public Utilities Commission (G.O. 95).
3. Dimension "A" may be less than 36 inches but shall be the maximum practicable.
4. Dimension "B" may be less than 36 inches provided that it is the maximum practicable and that the 8 foot minimum vertical clearances indicated are obtained.

ESR-2	Overhead Service Connections 0-600 Volts	APPROVED <i>PhH</i>
PAGE 2-20	Electrical Service Requirements ▶ SCE Public ◀	EFFECTIVE DATE 5-10-2002

Figure 2-8: Minimum Vertical Clearance of Service Drops—Industrial or Commercial

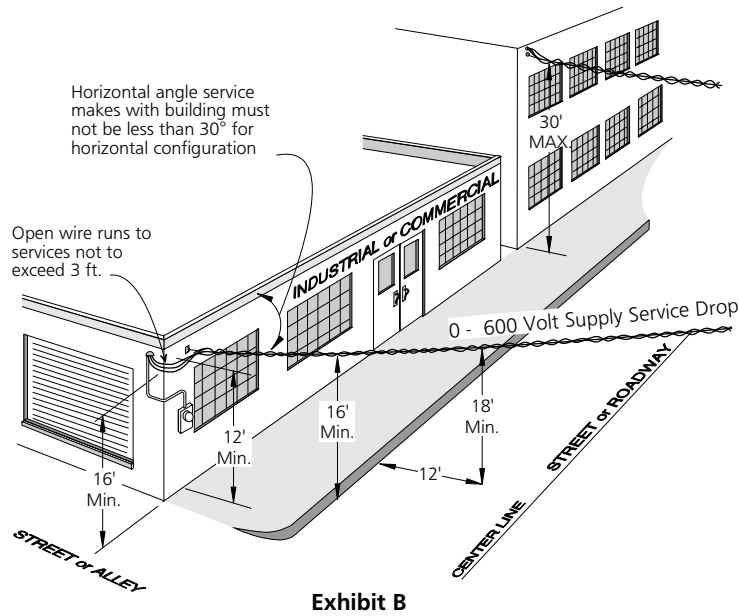
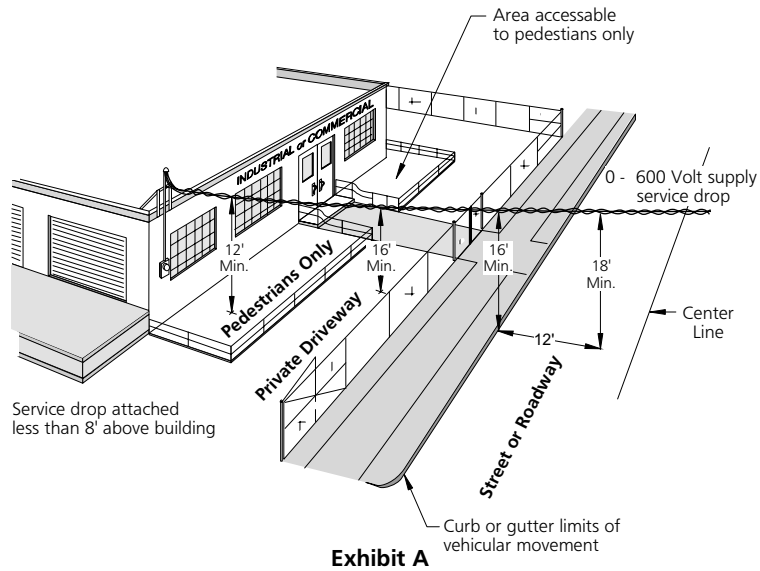

Notes

1. Clearance above structures upon which anyone can walk shall be 8 feet minimum.
2. Clearance of 0-600 Volt service drops from doors, windows, exits, fire escapes, etc. shall be as shown in [Figure 2-7 \(page 2-20\)](#).
3. Clearance of 0-600 Volt service drops over railroad tracks, areas capable of being traversed by agricultural equipment. See [Table 2-4 \(page 2-26\)](#).
4. Where service drops approach a building wall at an angle of less than 60 degrees the spacing of the insulators at the point of attachment in horizontal configuration should be increased so as to provide at least six inches conductor separation. Vertical configuration is normally preferable where the angle between the service drop and the wall is less than 60 degrees and is acceptable for any angle.
5. See [Figure 2-9 \(page 2-22\)](#) for exceptions for 0-600 volt service drops.

APPROVED <i>PhH</i>	Overhead Service Connections 0-600 Volts	ESR-2
EFFECTIVE DATE 5-10-2002	Electrical Service Requirements ▶ SCE Public ◀	PAGE 2-21

Figure 2-9: Service Drop Clearance – Commercial or Industrial Premises

Services of 0–600 Volts
These Minimum Clearances Apply to the Lowest Point of Service Drop Sag.

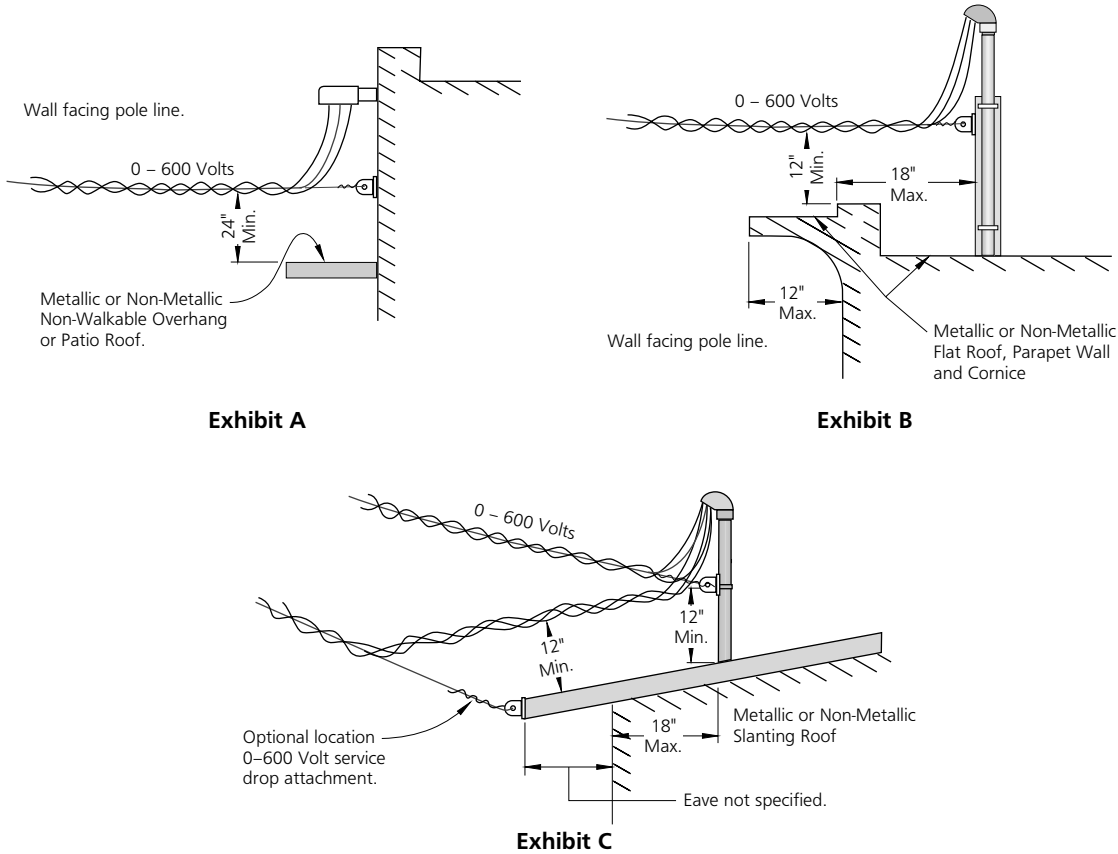

Notes

1. On premises used for Industrial and Commercial purposes, service drops shall be maintained at a vertical clearance of not less than 8 feet over all or any portions of buildings and structures. Except, that service drops of 0–600 Volts may be less than 8 feet, but not less than 12 inches above the metallic or non-metallic cornice, decorative appendage, eave, roof, or parapet wall of the building served provided: The current carrying service conductors are insulated for the voltage being supplied (See G.O. 95 Rule 20.8-G) and the point of attachment of the service drops is not more than 18 inches back of the front face of the building wall facing the pole line from which the service drops originate.
2. Service drops are not required to clear buildings any specific horizontal distance, but shall be so installed that they clear fire escapes, exits, windows, doors and other points at which human contact might be expected, a horizontal distance of not less than 3 feet. Where service drop crosses over metallic or non-metallic non-walkable overhang or patio cover the vertical clearance may be less than 8 feet, but not less than 24 inches providing such service drops consist of abrasion-resistant cables and are insulated for the voltage being supplied.
3. The above exhibits illustrate applications of G.O. 95 Rule 54.8-B4(a) to installations of 0–600 Volt service drops on various types of buildings on Commercial or Industrial premises.
4. The service drops shown are in flat configuration. The minimum vertical clearance of 12 inches applies to the lowest conductor of a service drop.

ESR-2	Overhead Service Connections 0–600 Volts	APPROVED <i>PhH</i>
PAGE 2-22	Electrical Service Requirements ▶ SCE Public ◀	EFFECTIVE DATE 5-10-2002

Figure 2-10: Clearance of Timber Risers on Buildings

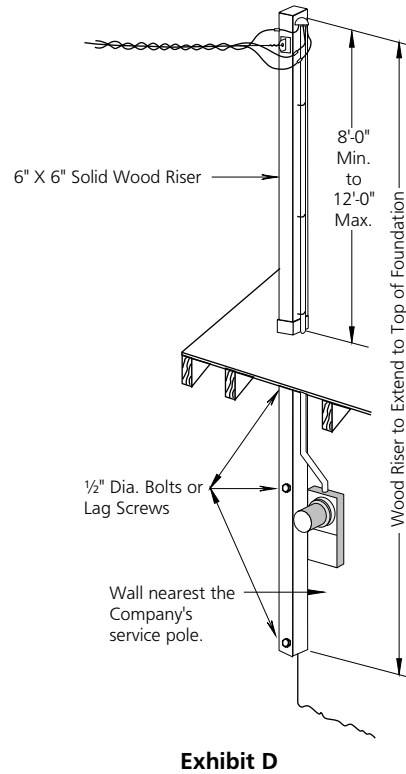
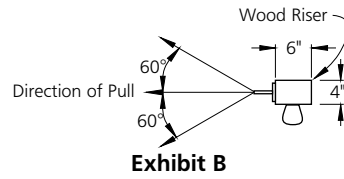
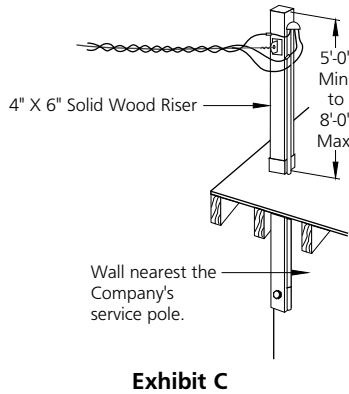
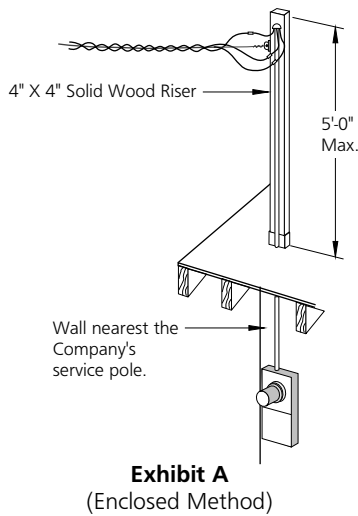

Notes

1. Service riser attachments in heavy snow loading areas shall have special construction. Contact the local Service Center office for information.
2. The service head wherever practicable should be located one foot above the level of the point provided for service drop attachment. Where the point of attachment is located above the service head, drip loops shall be formed and connections shall be made below the service head to prevent the entrance of moisture into the service conduit.
3. For clearances see [Figure 2-1 "Overhead Service Connections on Commercial & Industrial Buildings"](#) (page 2-14), [Figure 2-2 "Overhead Service Connections on Residential Building"](#) (page 2-15), [Table 2-4 "Vertical Clearances Above Railroads, Thoroughfares and Ground \(G.O. 95 Table - 1\)"](#) (page 2-26), [Figure 2-6 "Service Drop Clearance - Residential Premises"](#) (page 2-19), [Table 2-2 "Minimum Allowable Vertical Clearance Over Buildings and Structures 0-600 Volt Service Drops, Residential,"](#) (page 2-25), [Figure 2-7 "Clearance of 0-600 Volt Services from Doors, Exits, Windows, Fire Escapes"](#) (page 2-20), [Figure 2-8 "Minimum Vertical Clearance of Service Drops-Industrial or Commercial"](#) (page 2-21), [Figure 2-9 "Service Drop Clearance - Commercial or Industrial Premises"](#) (page 2-22), and [Figure 2-10 "Clearance of Timber Risers on Buildings"](#) (page 2-23).

APPROVED 	Overhead Service Connections 0-600 Volts	ESR-2
EFFECTIVE DATE 5-10-2002	Electrical Service Requirements ▶ SCE Public ◀	PAGE 2-23

7.5 Swimming Pool Clearances

The installation of conductors over or adjacent to swimming pools and the installation of pools beneath conductors shall be avoided where practicable. Where such installations are made the diagrams in **Figure 2-11** illustrate the minimum clearances required by the CPUC. Prior to installing any swimming pool in proximity to overhead conductors, contact the local inspection agency regarding applicable local ordinances.

The minimum clearances for supply conductors of all voltages in proximity to swimming pools are specified in General Order 95, Rule 54.4 A3. Consult the local Service Center office for details.

Figure 2-11: Swimming Pool Clearances

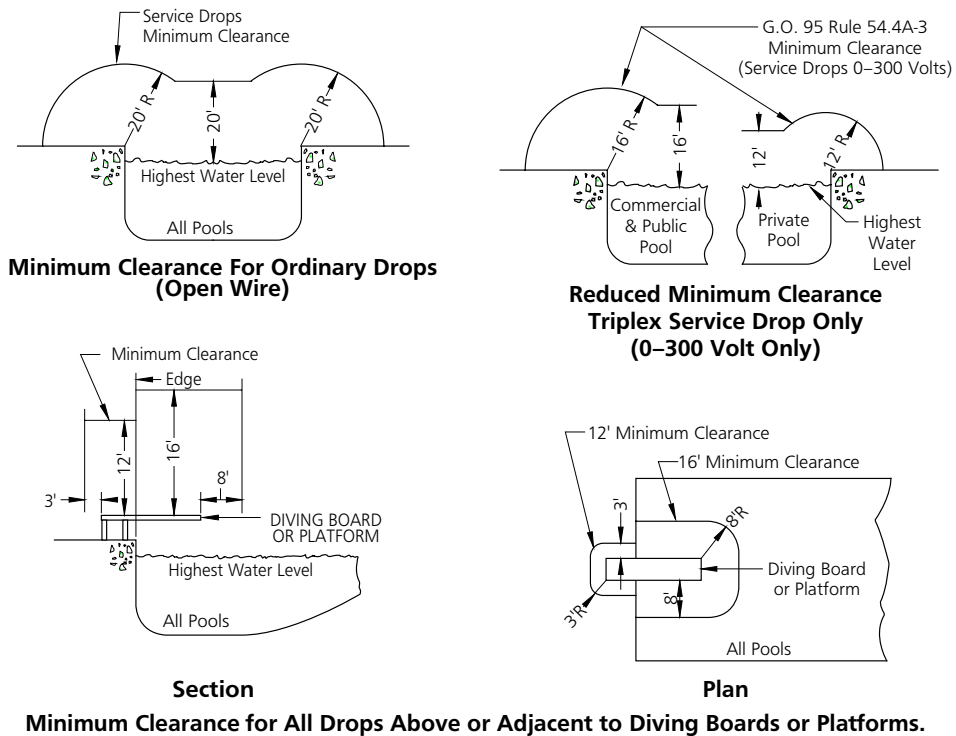

ESR-2	Overhead Service Connections 0-600 Volts	APPROVED <i>PhH</i>
PAGE 2-24	Electrical Service Requirements ► SCE Public ◀	EFFECTIVE DATE 5-10-2002

7.6 Minimum Allowable Clearances for Services Drops

The following Tables show the minimum allowable clearances for service drops above ground, and structures.

Table 2-2: Minimum Allowable Vertical Clearance Over Buildings and Structures 0-600 Volt Service Drops, Residential

Clearance From	Building Served	Other Buildings on Premises Served	Buildings on Other Premises
Metal roof less than 37° ^(a)	8 ft. Vertical ^(b)	8 ft.	8 ft.
Metal roof 37° or more	2 ft. Vertical ^(b)	2 ft.	8 ft.
Non-Metallic roof less than 37°	(c)	2 ft.	8 ft.
Non-Metallic Roof 37° or more	(c)	2 ft.	2 ft.
From fire escapes, exits, openable windows, doors and other points at which human contact might be expected.	3 ft. Horizontal See Figure 2-7 (page 2-20)		

- (a) A roof with a 3/8 pitch. See [Figure 2-12 \(page 2-25\)](#)
- (b) Residential triplex services may be installed a minimum of 12 inches above non-walkable metallic or non-metallic patio roofs.
- (c) A minimum of 12 inches but the greatest practicable clearance should be obtained.

Figure 2-12: Pitch of Roof

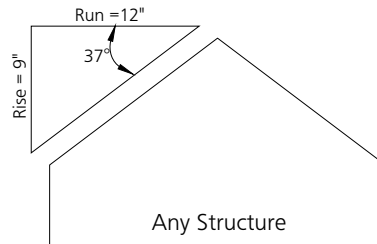

Table 2-3: Minimum Service Cable Clearance Above Ground

Location	Distance in Feet
At center of street.	18
At curb line.	16
Over Commercial or Industrial driveways or parking areas.	16
Over Residential Driveways.	12
Over Agricultural areas.	15
Over trolleys, railroads or for other special conditions.	Consult the Company representative.

APPROVED 	Overhead Service Connections 0-600 Volts	ESR-2
EFFECTIVE DATE 5-10-2002	Electrical Service Requirements ▶ SCE Public ◀	PAGE 2-25

**Table 2-4: Vertical Clearances Above Railroads, Thoroughfares and Ground
(G.O. 95 Table - 1)**

	Condition	Minimum Clearance
1.	Crossing above R.R. Tracks without overhead trolley wire	25 ft.
2.	Crossing above R.R. Tracks with overhead trolley wire: Above rails where freight cars are transported. Above rails where freight cars are not transported. In each case the service drop must clear trolley wires by not less than.	26 ft. 23 ft. 4 ft.
3.	Crossing above private driveways, or other areas accessible to vehicles, See Figure 2-6 (page 2-19) . If 12 ft. clearance requires a structure on the building served, 0-300 volt drop may have a clearance of:	12 ft. 10 ft.
4.	Crossing above areas accessible to pedestrians only. See Figure 2-6 (page 2-19) . If 10 ft. clearance requires a structure on the building served, 0-300 volt drops may have a clearance of: If 8-1/2 ft. clearance also requires a structure on the building served, the basic 10 ft. clearance must be maintained.	10 ft. 8½ ft.
5.	Crossing above areas capable of being traversed by agricultural equipment.	15 ft.
6.	Crossing above thoroughfares. See detailed requirements on Figure 2-6 (page 2-19)	18 ft.

8.0 Customer Owned Service and Meter Poles

8.1 General Requirements for Permanent and Temporary Service 0-600 Volts

The detailed minimum requirements for customer owned service and meter poles to which temporary or permanent service is to be extended by the Company are shown in [Figure 2-13 \(page 2-29\)](#) and [Figure 2-15 \(page 2-31\)](#). These pages are in compliance with the Rules of G.O. 95, the California Public Utilities Commission, and the California Construction Safety Orders, where applicable.

Service will not be connected to any customer owned service pole or service and meter pole which does not at least meet the minimum requirements shown on these pages. In some areas the requirements of local inspection authorities may exceed these requirements. When required, permit and inspection must be obtained from city, county or state inspection authorities before service will be connected by the company. Pole locations must be approved by the local Service Center office. The Company is not responsible for the location assumed by the contractor or customer.

Customers service may be taken from the receptacles or from top of pole with a second conduit run up the pole.

All conduit fittings to be rain tight. Wire with suitable insulation, not less than No. 8 AWG, shall be used in the conduit.

Service Switch to be rain tight and of proper rating for load to be served. Switch cover must be locked if enclosure contains exposed live parts. Service entrance circuit breaker may be used in lieu of a fused switch, unless threaded connections are employed. All sections of the service equipment shall be adequately bonded.

All boxes must be rain tight, where receptacles are used. They shall be of proper rating for load to be served. Receptacles used to connect portable tools shall be of the 3-pole type for single-phase motors and the 4-pole type for three-phase motors. One clip to be used for ground connections. Where more than one voltage is used, the receptacles shall not be interchangeable.

ESR-2	Overhead Service Connections 0-600 Volts	APPROVED <i>PhH</i>
PAGE 2-26	Electrical Service Requirements ▶ SCE Public ◀	EFFECTIVE DATE 5-10-2002

When single phase service larger than 100 amperes is required, or 3-phase service is desired, consult the company.

The service pole shall be placed at least 10 feet from the location of the company's pole, from which service is to be connected, and where practicable at least 10 feet laterally from the center of any pole line.

The service pole shall be placed within 100 feet from the location of the company's pole, from which service is to be connected.

The service pole shall be so located that the topography of the land, buildings, or other obstructions will not reduce required clearances per G.O. 95, Table 1.

The company will furnish and install the meter, service drop, and service drop wire holder. All other equipment, including the pole shall be furnished and installed by the customer.

Floodlights, signs, ropes and similar equipment shall not be attached to service and meter poles.

Communication service drops shall not be attached to service and meter poles unless all applicable G.O.95 clearances are complied with.

The drawings in [Figure 2-13 \(page 2-29\)](#) and [Figure 2-15 \(page 2-31\)](#) illustrate a typical socket meter installation for single and three-phase 0-600 volt service. The actual arrangement of the meter socket and service equipment may be varied provided that all of the requirements shown on these pages and all other Electrical Service Requirements of the Company are complied with.

All customer owned service poles by supporting the Company's overhead service conductors, are subject to the rules of G.O. 95 Overhead Line Construction of the Public Utilities Commission, except those poles which are so attached to, or which are so incorporated into a building or structure that they are not capable of being climbed.

The following is presented for assistance in correct and uniform interpretation of the requirements for customer owned service and meter poles as specified in [Figure 2-13 \(page 2-29\)](#) and in [Figure 2-15 \(page 2-31\)](#). These requirements are minimums with relation to the nature and composition of approved materials, together with clearance dimensions, and other features. Deviations from the requirements of these pages of any nature, including substitution of any types of material other than specified, cannot be granted. Service will not be connected to any installation which is not in compliance.

A. Temporary Service One Year or Less, requirements in [Figure 2-13 \(page 2-29\)](#).

The preferred location for temporary metered power poles shall be located where there is Company vehicle access and that the service drop maximum span length is 100 feet. If Company vehicle access cannot be obtained, contact the local service planning office for meter spot location.

A "self-supporting timber 6' x 6' x 20'-0" minimum" is required for the customers service pole. No particular variety or grade of timber is specified, but it is intended that it shall be sound, and free from large knots or other imperfections which would cause undue impairment of its strength.

A 5' x 3/4" schedule 40 PVC conduit will be furnished and installed by the customer. This conduit must be permanently secured with three pipe straps to the butt and flush to the bottom of the pole. The bottom of the conduit must be permanently capped and the top cap must be removable. See [Figure 2-13 \(page 2-29\)](#). This provides a means of inserting a measuring device in the conduit to check the actual setting depth.

APPROVED 	Overhead Service Connections 0-600 Volts	ESR-2
EFFECTIVE DATE 5-10-2002	Electrical Service Requirements ▶ SCE Public ◀	PAGE 2-27

The customer must set the service pole in natural soil. The backfill must be tamped to a minimum compaction of 90 percent within a 2-foot radius of the pole.

The customer shall furnish and install a 10' service drop stinger. The service drop stinger shall be #4 aluminum triplex for a 100 amp service and 1/0 aluminum triplex for a 200 amp service.

A timber is by dictionary definition "a squared or dressed piece of wood, usually of large dimensions." Any wood pole type structure laminated or assembled as a group of separate pieces, does not comply with these requirements. A single timber only, complies. The pole butt shall be treated with a preservative.

B. Permanent or Temporary Service; Requirements in [Figure 2-15 \(page 2-31\)](#).

A "25 foot pole with 5 inch minimum top diameter" is required. This means the standard round full length commercially pressure treated with a chemical preservative pole in general use for line construction. It is the intent that such pole shall be equal in quality and extent of treatment to a pole which would be used by the Southern California Edison Company in the area concerned. This will permit the optional use of commercially butt treated standard round cedar poles in the San Joaquin Valley and desert areas. Full length treated poles shall be used elsewhere. Brush treated poles do not comply with these requirements. Sawed timbers are not permitted under any circumstances.

In locations where 25 foot poles of the required type are not readily purchasable from other sources, such poles may be purchased from the Company. Requirements are in [Figure 2-15 \(page 2-31\)](#). Contact the local Service Center office for details.

8.2 Wood Brace for Temporary Service Requirements One Year or Less: Requirements in [Figure 2-14 \(page 2-30\)](#).

Where the soil is not firm (*i.e.*, unable to obtain a 90 percent compaction, sandy, or imported soil, etc.) bracing shall be required to ensure the stability of the temporary power pole. The wood brace shall not be smaller than a 2" x 4" timber and shall be secured to the pole with a minimum 1/2-inch bolt. See [Figure 2-14 \(page 2-30\)](#).

ESR-2	Overhead Service Connections 0-600 Volts	APPROVED 
PAGE 2-28	Electrical Service Requirements ▶ SCE Public ◀	EFFECTIVE DATE 5-10-2002

Figure 2-13: Temporary Service Requirements (Service for One Year or Less)

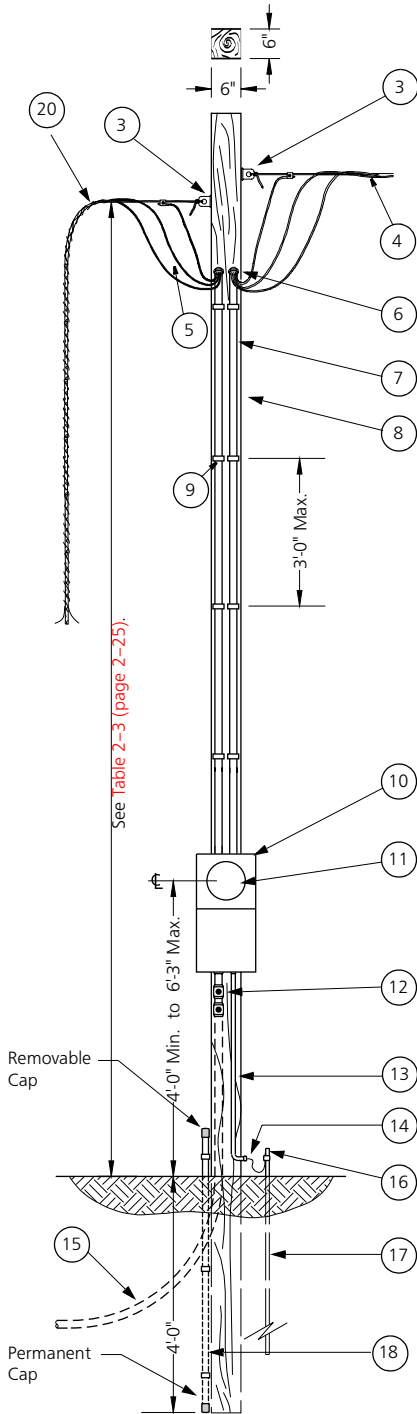

Notes

1. The preferred location for temporary metered power poles shall be located where there is **Company vehicle access** and that the service drop maximum span length is 100 feet. If Company vehicle access cannot be obtained, contact the local service planning office for meter spot location.
2. Service drop furnished and installed by the company. The Company's service drop maximum span length is 100 feet.
3. Wire holder or rack furnished and installed by the customer.
4. Customer's line.
5. Not less than 18 inches of wire outside service head.
6. Weatherproof service entrance caps.
7. Minimum 3/4-inch polyvinyl chloride plastic conduit schedule 40.
8. Self supporting timber 6" x 6" x 20'-0" minimum. (Butt treated).
9. Fasten conduit securely to pole.
10. For type of meter receptacle, and the number of socket terminals, see **ESR-5: Table 5-3** and **ESR-5: Figure 5-2**.
11. Meter will be furnished and installed by the company. A safety socket box with factory installed test/bypass blocks, as detailed in **ESR-5: Section 9.0 "Factory Wired Safety Socket Boxes"** shall be provided for all three phase installations.
12. Weatherproof boxes and receptacles.^{3/}
13. Armored ground wire or minimum of 1/2-inch Rigid conduit or wood molding over ground wire.
14. Ground wire to be No. 8 A.W.G., minimum.
15. Where customer's feeder is to be underground, install conduit as indicated by dashed lines and as required by the NEC.
16. Approved ground clamp and fitting must be accessible. Conduit must extend to ground rod to protect ground wire from mechanical injury.
17. Ground wire from pole to electrode shall be enclosed in galvanized ridged conduit, or equivalent mechanical protection. If a ground rod is used, the following minimum requirements apply:
Diameter of rod: 3/4 inch, if iron rod or galvanized pipe, 1/2 inch if solid rod of brass, copper, or copper covered steel. Drive to minimum depth of 8'-0" below ground surface. Refer to the local inspection agency for alternate or additional requirements.
18. A 5' x 3/4" schedule 40 PVC conduit will be furnished and installed by the customer. This conduit must be permanently secured with three pipe straps to the butt and flush to the bottom of the pole. The bottom of the conduit must be permanently capped and the top cap must be removable.
19. The customer must set the service pole in natural soil. The backfill must be tamped to a minimum compaction of 90 percent within a 2-foot radius of the pole.
20. The customer shall furnish and install a 10 foot service drop stinger. The service drop stinger shall be #4 aluminum triplex for a 100 amp service and 1/0 aluminum triplex for a 200 amp service.

3/ Refer to the local inspection agency and the California Electrical Safety Order for ground fault circuit protection requirements.

APPROVED <i>PhH</i>	Overhead Service Connections 0-600 Volts	ESR-2
EFFECTIVE DATE 5-10-2002	Electrical Service Requirements ▶ SCE Public ◀	PAGE 2-29

Figure 2-14: Wood Brace for Temporary Service Requirements (Service for One year or Less)

Where the soil is not firm (i.e., unable to obtain a 90 percent compaction, sandy, or imported soil, etc.) bracing shall be required to ensure the stability of the temporary power pole. The wood brace shall not be smaller than a 2" x 4" timber and shall be secured to the pole with a minimum 1/2-inch bolt.

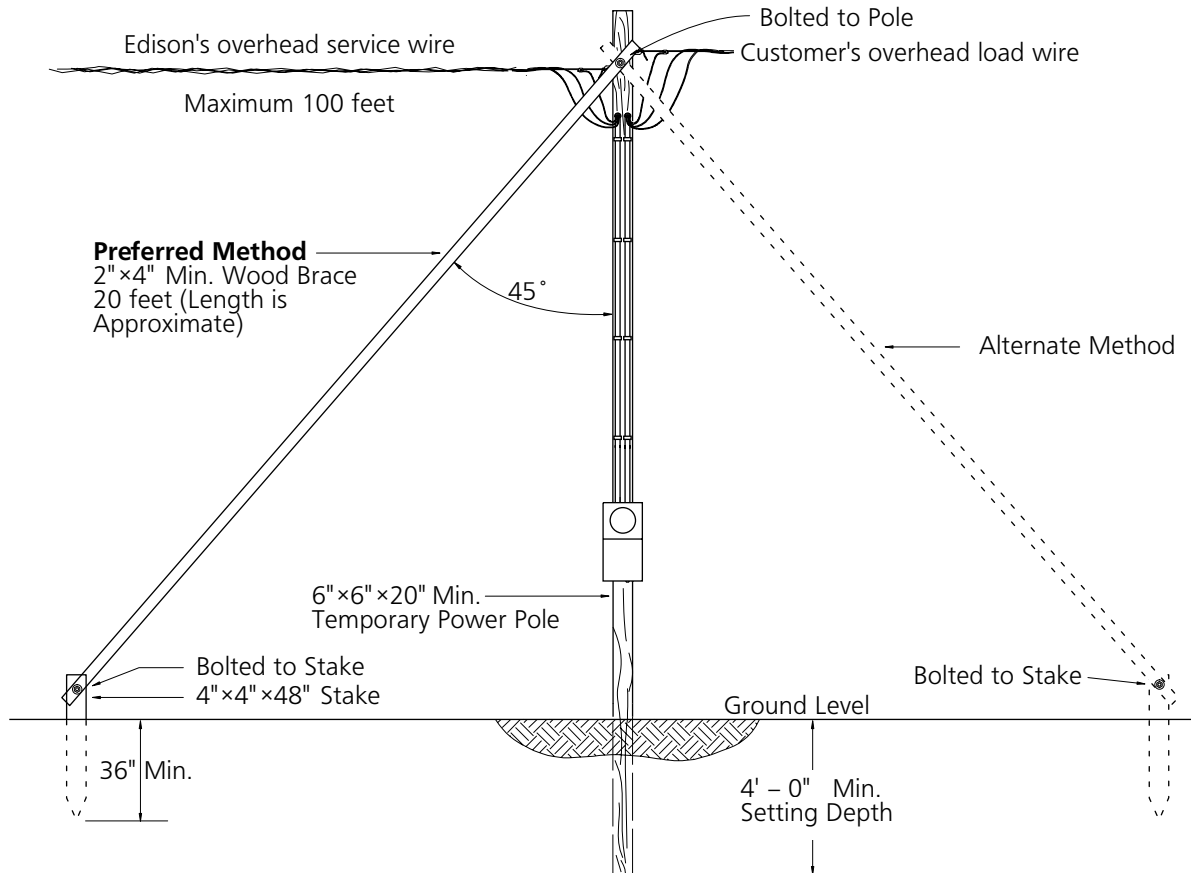

Notes

1. Place wood brace in-line with service drop.
2. Bolt the 2" x 4" x 20' min. wood brace 6 inches below the top of the 6" x 6" x 20' timber and 6 inches below top of the 4" x 4" x 48" stake with a minimum 1/2-inch bolt.
3. If the location of the temporary power pole prohibits placing the wood brace in the preferred method, the alternate bracing method can be used.
4. Soil conditions, may require setting the temporary power pole deeper than 4 feet. Should the temporary power pole be set deeper than the 4 foot requirement, clearances shall be maintained for the service drop. See [Figure 2-8 "Minimum Vertical Clearance of Service Drops—Industrial or Commercial"](#) (page 2-21).
5. The bracing method can be used if the service conductor is greater than #4 Aluminum Triplex.

ESR-2	Overhead Service Connections 0-600 Volts	APPROVED <i>PhH</i>
PAGE 2-30	Electrical Service Requirements ▶ SCE Public ◀	EFFECTIVE DATE 5-10-2002

Figure 2-15: Customer Owned Permanent or Temporary Service Pole

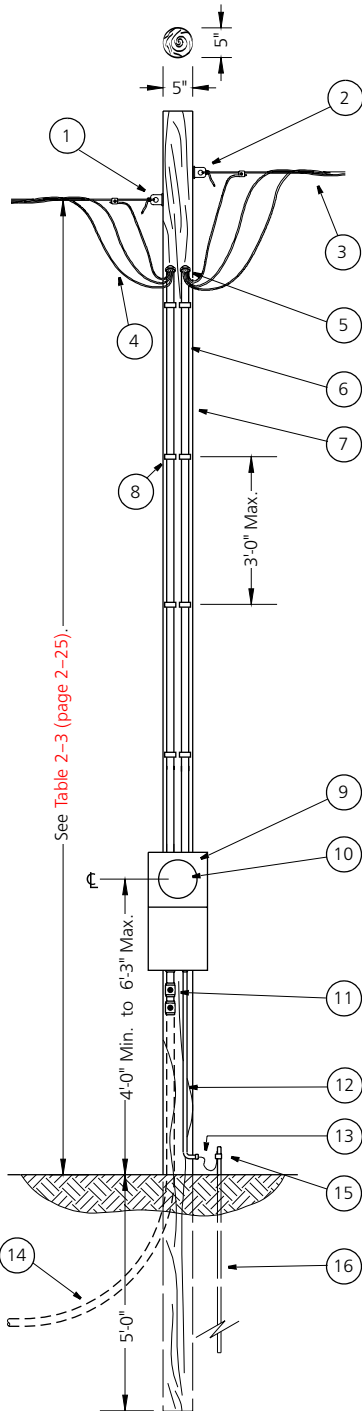

Notes

1. Service drop and wire holder or service rack furnished and installed by the company. The Company's service drop maximum span length is 100 feet.
2. Wire holder or rack furnished and installed by the customer.
3. Customer's line.
4. Not less than 18 inches of wire outside service head.
5. Weatherproof service entrance caps.
6. Minimum 3/4-inch polyvinyl chloride plastic conduit schedule 40.
7. A twenty-five foot pole with a 5 inch minimum top diameter treated with a chemical preservative.
8. Fasten conduit securely to pole.
9. For type of meter receptacle, and the number of socket terminals, [ESR-5: Table 5-3](#) and [ESR-5: Figure 5-2](#).
10. Meter will be furnished and installed by the company. A safety socket box with factory installed test/bypass blocks, as detailed in [ESR-5: Section 9.0 "Factory Wired Safety Socket Boxes"](#) shall be provided for all three phase installations.
11. Weatherproof boxes and receptacles.^{4/}
12. Armored ground wire or minimum of 1/2-inch Rigid conduit or wood molding over ground wire.
13. Ground wire to be No. 8 A.W.G., minimum.
14. Where customer's feeder is to be underground, install conduit as indicated by dashed lines and as required by the NEC.
15. Approved ground clamp and fitting must be accessible. Conduit must extend to ground rod to protect ground wire from mechanical injury.
16. Ground wire from pole to electrode shall be enclosed in galvanized ridged conduit, or equivalent mechanical protection. If a ground rod is used, the following minimum requirements apply:
Diameter of rod: 3/4 inch, if iron rod or galvanized pipe, 1/2 inch if solid rod of brass, copper, or copper covered steel. Drive to minimum depth of 8'-0' below ground surface. Refer to the local inspection agency for alternate or additional requirements.

4/ Refer to the local inspection agency and the California Electrical Safety Order for ground fault circuit protection requirements.

APPROVED <i>PhH</i>	Overhead Service Connections 0-600 Volts	ESR-2
EFFECTIVE DATE 5-10-2002	Electrical Service Requirements ▶ SCE Public ◀	PAGE 2-31

Figure 2-16: Optional Customer Owned Service and Meter Pole

Permanent or Temporary

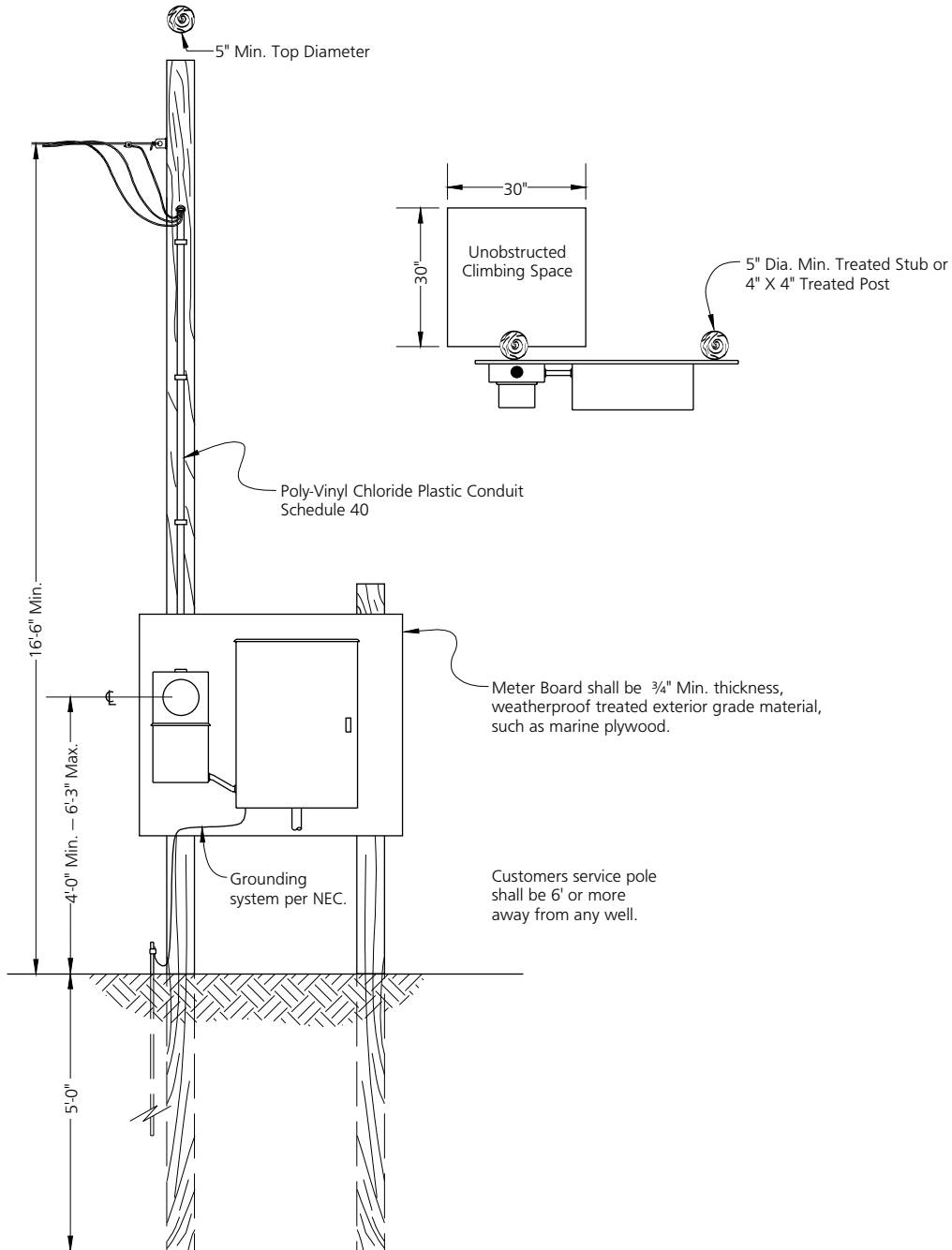

<p>ESR-2</p>	<p>Overhead Service Connections 0-600 Volts</p>	<p>APPROVED <i>PhH</i></p>
<p>PAGE 2-32</p>	<p>Electrical Service Requirements ▶ SCE Public ◀</p>	<p>EFFECTIVE DATE 5-10-2002</p>

9.0 High Voltage Connections 2,400, 4,160, 4,800, 7,200, 12,000, 16,500 & 33,000 Volts

9.1 General

To properly coordinate the provisions of these Requirements with the installation of overhead services for the direct delivery of energy to the customer at any voltage exceeding 600 volts, each installation will necessitate special engineering. This will require that the engineer, contractor or customers' representative consult the Company with respect to all pertinent details prior to planning such high voltage service installation.

Overhead service will not be supplied in an area designated as an Underground District except where required by the Company for its operating necessity.

Underground Service is recommended for all High Voltage Services to Buildings.

9.2 Service

Upon a bona fide application for service, and where the Company's distribution pole line is located on the customer's premises, or on a street, highway, lane, alley, road or private easement immediately contiguous thereto, the Company will furnish and install a single span of supply conductors from its pole to the customer's first approved permanent support; provided such support is of a type and is so located that such conductors may be installed in accordance with good engineering practice, and in compliance with the requirements of the Company, together with all applicable laws, ordinances, rules and regulations, including those governing clearances and points of attachment.

The customer shall, at their own expense, upon request by the Company, provide a new support in a location approved by the Company, for the termination of the Company's existing supply conductors, together with such service entrance conductors as may be required in order to comply with the foregoing, whenever any of the clearances required from such conductors to the ground or to any object between the Company's existing serving pole and (or at) the point of their termination on the customer's support, become impaired by reason of any changes made by the owner or tenant of the premises.

A company representative will, in each case, designate all details of the manner in which a high voltage overhead service will be extended to and terminated on the customer's structure. The Company will furnish and install the service dead end insulators on the customer's structure.

9.3 Single Phase Service Capacity

Normally the maximum permissible single phase load permitted to be connected to any one Phase of the Company's system is as follows: 2,400 volts, single phase – 150 kVA 12 kV or 16 kV, single phase – 1,000 kVA These values may be increased where special facilities are installed by the Company.

9.4 Three Phase Service Capacity

The maximum main switch capacity for a 2,400 or 4,160 volt three phase service is 3,000 amperes. Where greater capacity is required, two or more services may be installed with totalized metering. For higher voltage services, consult the Company.

APPROVED 	Overhead Service Connections 0–600 Volts	ESR–2
EFFECTIVE DATE 5-10-2002	Electrical Service Requirements ▶ SCE Public ◀	PAGE 2–33

9.5 Single point of Service Delivery

Normally, only one point of service delivery will be established for the same phase and voltage class of load to be served on any single continuous Premises. The Company shall be consulted with respect to the location of service delivery prior to planning provisions for the reception of service.

9.6 Service Support – Customer’s Service Pole

When a 2,400, 4,160, 4,800 and 7,200 volt service is to be provided, and a customer maintains an overhead distribution system he may furnish and install a meter and service pole, in a location approved by the Company. Such pole shall be subject to local and state ordinances.

When a 12,000 volt, 16,500 and 33,000 volt service is to be provided and a customer maintains an overhead distribution system the company will furnish and install the metering pole, metering facilities, and one span of metered overhead service.

The customer shall furnish and install a main disconnecting means with over current protection, on their service pole or the next adjacent pole. Where a customer is served directly from a distribution circuit or an autotransformer, the main disconnect shall be a circuit breaker equipped with over current and ground relaying/protection.

Where a customer is served by a dedicated two-winding power transformer the main disconnect may be a circuit breaker or switch-and-fuse combination of a type and with current carrying and interrupting capacities acceptable to the Company. See [ESR-7: Section 19.0 "Service and Meter Switch"](#).

Consult the Company regarding available fault duties and coordination of protection.

ESR-2	Overhead Service Connections 0-600 Volts	APPROVED <i>PhH</i>
PAGE 2-34	Electrical Service Requirements ▶ SCE Public ◀	EFFECTIVE DATE 5-10-2002

Figure 2-17: Busway Service Head Requirements 3Ø 4-Wire Wye or Delta, 600V Maximum

EUSER DRAWING NO. 349

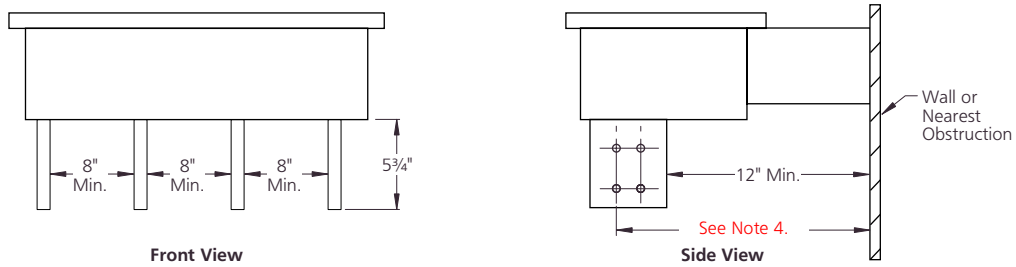

Terminating facilities the same length (4-Wire shown)

Exhibit A

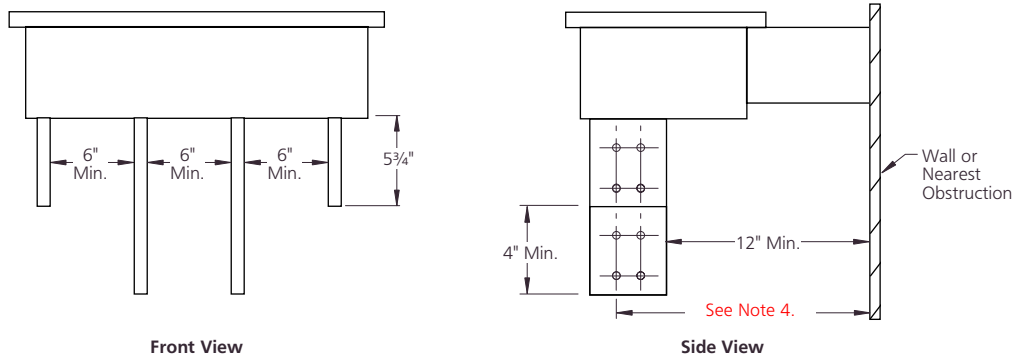

Terminating facilities not the same length (4-Wire shown)

Exhibit B

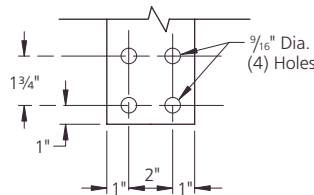

Drilling Detail for Landing Terminals
(800 ampere terminal shown)
See Notes 1, 2 and 3.

Exhibit C

Notes

1. One terminal landing position is required for each 400 amperes of service ampacity (or portion thereof). Each landing position shall consist of two 9/16 inch holes spaced on 1-3/4 inch vertical centers. When multiple landing positions are required, the horizontal spacing between landing positions shall be 2 inches (minimum).
2. Neutral terminal shall be permanently marked by the manufacturer.
3. For 120/240 volts three-phase four-wire services, the power leg ("C" phase) terminal shall be permanently marked in an orange-color by the manufacturer.
4. The maximum dimension from the building or nearest obstruction to the outermost landing position shall not exceed 25 inches unless approved by the Company.
5. Service heads with enclosed terminating positions are not permitted.
6. The clearances indicated between phases is for single cable lug mounting only, not multiple cable stacking lugs.

APPROVED <i>PhH</i>	Overhead Service Connections 0-600 Volts	ESR-2
EFFECTIVE DATE 5-10-2002	Electrical Service Requirements ▶ SCE Public ◀	PAGE 2-35

ESR-3

**UNDERGROUND
SERVICE
CONNECTIONS
0-600 VOLTS**

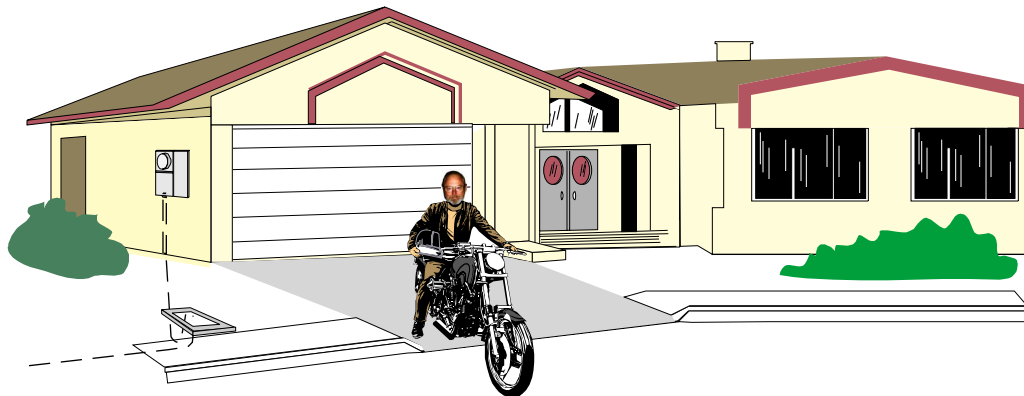

TDBU
► **SCE Public** ◀



**SOUTHERN CALIFORNIA EDISON
TDBU**

ESR-3: Underground Service Connections 0-600 Volts

TABLE OF CONTENTS

Section No.	Title	Page
1.0	Underground Service Connections	3-5
2.0	Service Capacity 0-600 Volts	3-5
2.1	Single-Phase Service - 120/208, 120/240, 240, and 240/480 Volts	3-5
2.2	Three-Phase Service - 120/208, 240 and 277/480 Volts.	3-5
3.0	Service Capacity 600 Volts and Above.	3-6
3.1	Single-Phase Services	3-6
3.2	Three-Phase Services.	3-6
4.0	Service Specifications	3-6
4.1	Easement.	3-7
4.2	Bill of Sale	3-7
4.3	Permits.	3-7
5.0	Temporary Service Connections	3-7
6.0	Underground Service From An Overhead Source	3-8
6.1	Pole Riser (Conduit)	3-8
6.2	Service Termination Facilities.	3-8
6.3	Service Conductors.	3-8
7.0	Company Owned Transformers Installed on Customer's Premises.	3-9
8.0	Underground Service From an Underground Source	3-9
9.0	Single Point of Service Delivery Per Building.	3-10
10.0	Single Point of Service Delivery for Each Premises	3-10
11.0	Factory Built/Modular Homes	3-10
12.0	Location of Point of Service	3-10
12.1	Low voltage service (0-600 volts)	3-10
12.2	Service (above 600 volts)	3-11
13.0	Service Conduit Installations	3-11
13.1	Size and number of conduits	3-11
13.2	Depth of Conduit	3-11

APPROVED 	Underground Service Connections 0-600 Volts	ESR-3
EFFECTIVE DATE 7-30-2004	Electrical Service Requirements ▶ SCE Public ◀	PAGE 3-1

TABLE OF CONTENTS

Section No.	Title	Page
13.3	Route of Conduit	3-12
13.4	Maximum Length of Conduit	3-12
13.5	Pull Rope or Muletape in Conduit	3-12
13.6	Bends in Conduit	3-12
13.7	Inspection of Conduit	3-12
14.0	Service Conduit Entry Into Building Served	3-13
14.1	Residential Buildings 0-600 Volts	3-13
14.2	Commercial Buildings 0-600 Volts	3-13
14.3	Services 2,400-16,500 Volts.	3-13
15.0	Terminating Enclosures	3-13
15.1	Type Required For Service 0-600 Volts	3-13
15.2	Type Required For Service Above 600 Volts	3-14
15.3	Subway Type Terminating Enclosures	3-14
15.4	Subway Type Terminating Pull Boxes	3-14
15.5	Wall Mounted Type Terminating Pull Boxes and Switchboard Pull Sections	3-14
15.6	Access to and Working Space in Front of Termination Enclosures.	3-15
16.0	Electric Meter Rooms	3-15
16.1	Access	3-15
16.2	Doors.	3-16
16.3	Foreign Equipment	3-16
16.4	Headroom	3-17
16.5	Illumination	3-17
16.6	Meter Clearances	3-17
16.7	Meter Marking	3-19
16.8	Room Identification	3-19
16.9	Vehicle Access	3-19
16.10	Meter Heights	3-19
16.11	Working Space - Metering and Service Equipment.	3-19
16.12	Protective Barriers for Service Equipment.	3-22

ESR-3	Underground Service Connections 0-600 Volts	APPROVED 
PAGE 3-2	Electrical Service Requirements ▶ SCE Public ◀	EFFECTIVE DATE 7-30-2004

LIST OF TABLES

Table No.	Title	Page
3-1	Conduit or Cable System Minimum Cover	3-12
3-2	Meter Room–Meter Clearances.	3-18
3-3	Approved Riser Bend Materials and Sizes	3-23
3-4	Concrete Encasement Schedule	3-24
3-5	Edison Approved Service Conduit Material	3-25
3-6	Handhole, Pull Box and Manhole Application and Size.	3-41
3-7	Terminating Pull Section Minimum Dimensions	3-45

LIST OF FIGURES

Figure No.	Title	Page
3-1	Meter Room Clearances	3-18
3-2	Working Space and Clearance Requirements 0-600 Volts.	3-21
3-3	Protective Barrier for Service Equipment Installation Requirements.	3-22
3-4	Typical Riser At Pole – Various Voltages	3-23
3-5	Customer Conduit Installation and Typical Concrete Conduit Encasement	3-24
3-6	Underground Combination Meter Panel 0–600 Volts.	3-25
3-7	Meter Panel for Single-Family Residential Underground Service, 300/400 Ampere (Class 320), 120/240 Volt Single Phase 3–Wire	3-26
3-8	Underground Service Terminating Facilities for Residential Multiple Occupancy Service – 6 Meters Single Phase 3–Wire, 0–600 Amps, 0–600 Volts	3-27
3-9	Underground Pull Box Equipped with Cable Terminations for Commercial or Residential use 0–600 Volts, 0–1,200 Amps.	3-29
3-10	Combination Disconnecting Device and Terminating Enclosure 0–600 Volts, 1,200 Amperes Maximum	3-30
3-11	Underground Pull Boxes	3-31
3-12	Typical Service Lateral Installation for Single Family Residence	3-32
3-13	Typical Service Conversion From Overhead to Underground.	3-33
3-14	Myers Plug-In-Type Meter Adapter.	3-34
3-15	Plug–In Temporary (Piggy Back) Service Adapter	3-34
3-16	Temporary Service From A Padmount Transformer.	3-35
3-17	Temporary Service From Secondary Hand Hole, Pull Box or Pedestal	3-36
3-18	Riser Bend for Multi–Family Residential Service Entrance, and (Recessed Service Applications) 3-37	
3-19	Service Entrance for Single Family Dwelling Service	3-38

APPROVED 	Underground Service Connections 0–600 Volts	ESR–3
EFFECTIVE DATE 7-30-2004	Electrical Service Requirements ▶ SCE Public ◀	PAGE 3–3

LIST OF FIGURES

Figure No.	Title	Page
3-20	Exposed Service Conduit Installation	3-39
3-21	Riser Bend Installation at Wall or Pad	3-40
3-22	Handholes, Pull Boxes and Manholes	3-41
3-23	Typical Mobile Home or Residential Service and Meter Post Maximum 200 Amps 120/240 Volts	3-42
3-24	Typical Underground Layout for Mobile Homes	3-44
3-25	Non-Residential Service Pedestals 0-200 Amperes, 0-600 Volts.	3-45

ESR-3	Underground Service Connections 0-600 Volts	APPROVED <i>PhH</i>
PAGE 3-4	Electrical Service Requirements ▶ SCE Public ◀	EFFECTIVE DATE 7-30-2004

1.0 Underground Service Connections

Overhead service will not be supplied to any building or premises in an area designated as an underground designated locations. In areas where both overhead and underground service facilities exist, the Company shall be consulted for determination of the type of service that will be supplied.

2.0 Service Capacity 0–600 Volts

The capacity supplied by one service will be governed by the following specifications:

2.1 Single-Phase Service - 120/208, 120/240, 240, and 240/480 Volts

The maximum rating of an individual meter switch for 120/208 volt, three-wire service is 200 amperes. Normally for 120/240 or 240 volt service, the maximum meter switch rating is 400 amperes and 200 amperes for 240/480 volt services. Under certain operating conditions, permission may be granted for installation of 600 amperes service equipment for an individual 120/240 or 240 volt load. Otherwise two or more separate 400 amperes service installations may be required, and totalized metering will be available. Consult the local Service Planning office for requirements.

On multiple occupancy buildings consult the local Service Planning office for load requirements. Refer to Sections 9.0 and 10.0 (page 3–10) for group metering requirements.

Single-phase 240 volt two-wire load may in some cases be supplied from a three-phase source by a three-phase service and balanced across the three phases. Consult the local Service Planning office for details.

2.2 Three-Phase Service - 120/208, 240 and 277/480 Volts

Normally, for a given voltage or phase, only one set of service conductors with one meter switch which carries a customer's entire load will be permitted to a single occupancy. In all cases, the Company shall be consulted relative to available voltage and method of service delivery prior to making the service installation. The maximum main switch capacity allowed for 120/208, 240 or 277/480 volts three-phase is 4,000 amps of connected load. When capacities exceeding 4,000 amperes is required, two or more services may be installed with totalized metering, see ESR–6: Section 5.0 "Totalized Services".

Three-phase service will only be supplied to a residence if a three-phase voltage is available at the location or there is one motor of more than 10 hp.

Three-phase 240 volt service shall be available to customers who qualify from Company owned transformers located on the customer's premises, when in the opinion of the Company, such space is considered necessary.

Service may be supplied at 120/208 volts wye provided: (1) the Company maintains a four-wire 120/208 volt wye system, or (2) the customer's load would require an individual transformer installation of not less than 15 kVA, and (3) the transformer installation is located on the customer's premises, when in the opinion of the Company such space is considered necessary.

In the Long Beach 120/208 volt network area, connected loads in excess of 300 kVA will normally be served from Company owned transformers located on the customers premises. Consult the local Service Planning office for details.

APPROVED 	Underground Service Connections 0–600 Volts	ESR–3
EFFECTIVE DATE 7-30-2004	Electrical Service Requirements ▶ SCE Public ◀	PAGE 3–5

Service may be supplied at 120/240 volt, three-phase, four-wire delta provided: (1) the Company maintains a four-wire delta secondary system, (2) the installation requires not less than 15 kVA of transformer capacity, (3) the unbalance between phases is less than 100 kW, and (4) the service transformers are located on the customer's premises, when in the opinion of the Company such space is necessary.

All 277/480 volt services shall be available only to customer's who qualify and Company owned transformers are located on the customer's premises, when in the opinion of the Company such space is considered necessary.

3.0 Service Capacity 600 Volts and Above

Consult the local Service Planning office with respect to special requirements prior to planning any high voltage service installations.

A set of service cables may consist of a single run or more than one operating in parallel, with each run in a separate conduit. The maximum demand load which will be supplied by a single run is 400 amperes.

3.1 Single-Phase Services

Normally the maximum permissible single-phase load proposed to be directly connected to any one phase of the Company's system is as follows:

- Single-phase service at 2,400 volts - 150 kVA
- Single-phase service at 12,000 volts or 16,500 volts - 1,000 kVA

These values may be increased where special facilities are installed by the Company.

3.2 Three-Phase Services

The maximum main switch capacity for a 2,400 or 4,160 volt three-phase service is 3,000 amperes. When service capacity exceeding 3,000 amperes is required, two or more services may be installed with totalized metering. For higher voltage services, consult the local Service Planning office.

4.0 Service Specifications

Company approval is required for specifications of installations involving any underground structures other than service conduits and pull boxes. Such specification must comply with all applicable codes, laws, ordinances, and similar regulations.

Company approval is required in advance of construction for the locations and types of structures installed for Company use.

In certain cases Company inspection will be required during installation of structures for Company use. Consult the local Service Planning office to ascertain if inspection is required. Notice must be given 48 hours prior to construction to obtain this inspection. These inspections may not negate requirements of the local building and safety departments for inspection of the facilities being installed.

All installations on the customers premises are made by the customer. Installations of service conduit and its appurtenant structures for service from an overhead line source, both on and off the customer's premises, are made by the customer, under the conditions specified for **Section 6.0 "Underground Service From An Overhead Source" (page 3-8)**.

All grounding materials shall be furnished and installed by the customer. Contact the local Service Planning office for requirements on specific installations.

ESR-3	Underground Service Connections 0-600 Volts	APPROVED <i>PhH</i>
PAGE 3-6	Electrical Service Requirements ▶ SCE Public ◀	EFFECTIVE DATE 7-30-2004

When service conduits are encased in 2 inches or more of concrete, or under 2 inches or more of concrete floor, they are considered to be outside of the building by the National Electrical Code, see the paragraphs in [Section 6.3 "Service Conductors" \(page 3–8\)](#), [Section 8.0 "Underground Service From an Underground Source" \(page 3–9\)](#) and [Section 15.5 "Wall Mounted Type Terminating Pull Boxes and Switchboard Pull Sections" \(page 3–14\)](#).

4.1 Easement

Where a customer's service conduit passes through property other than the premises being served, the Company shall obtain an easement for the service conduit from the owner of such property. In the event the Company is unable to do so, it shall become the responsibility of the customer to negotiate the easement.

In certain cases, where in the opinion of the Company, the circumstances warrant, the customer may be required to furnish an easement to the Company for the service conduit and its appurtenances. This requirement will particularly apply where two or more premises are supplied by branch service conduits from a pull box at the end of or in the run of a main service conduit. In such cases the Company will require an easement from each property owner over whose premises any such conduit passes to supply other premises.

4.2 Bill of Sale

In cases where two or more premises are supplied by a single main service conduit and its appurtenant pull box(s), and in certain other cases where, in the opinion of the Company, the circumstances warrant, a bill of sale conveying ownership of conduits and their appurtenances to the Company will be required.

4.3 Permits

Where any governing authority requires the issuance of a permit for an underground service installation on the premises of the customer or on other private property, the customer shall obtain such permit(s). In cases where the service is supplied from an overhead source and any part of the installation is located on a public way, the customer will normally obtain any required permit(s). Where a permit for the portion on the public way is not available to the customer, the Company will construct that portion only. The Company will bill the customer for the cost of construction, the permit fee(s), and any inspection required by the permit.

5.0 Temporary Service Connections

A service connection for temporary use during construction may be made from an underground source provided the customer installs the necessary structures, facilities, and makes a sufficient deposit to cover all cost of those portions which do not become a part of the permanent service. To keep the temporary installation and removal cost to a minimum the facilities for the permanent service should be completed to the fullest extent practicable. See [Figure 3–15 \(page 3–34\)](#) and [Figure 3–16 \(page 3–35\)](#).

A temporary conduit may be installed from a permanent pull box at the end of or in the run of the permanent service conduit. This conduit may connect to suitable temporary metering equipment with conductors installed by the customer. See [Figure 3–17 \(page 3–36\)](#) for typical cable-in-conduit (CIC) temporary underground service connections.

The customer shall pay required fees and make applications for all temporary service connections.

APPROVED 	Underground Service Connections 0–600 Volts	ESR–3
EFFECTIVE DATE 7-30-2004	Electrical Service Requirements ▶ SCE Public ◀	PAGE 3–7

6.0 Underground Service From An Overhead Source

Any customer, desiring the service conductors underground for low or high voltage 0–33,000 volts, including conductors supplying Company owned transformers in a vault or enclosure, shall furnish, install, and maintain at their expense, conduit, or conduit as specified by these requirements. The Company will determine the size of the conduit and number of runs to be installed in each case.

6.1 Pole Riser (Conduit)

The conduit on the pole shall be PVC conduit, fittings and miscellaneous material shall comply with or be equal to current Company specification number MS–215.

Refer to [Figure 3–4 \(page 3–23\)](#) of these requirements for minimum conduit size, application and installation practices.

The conduit and necessary miscellaneous material and fittings shall be furnished and installed on the pole as follows:

- The Company will furnish all materials and charge the customer the cost thereof. The Company will erect, own and maintain this material on the pole at its expense; or

6.2 Service Termination Facilities

The customer shall furnish, install and maintain at their expense, facilities for the termination of the service conduit at the load end, together with any intermediate pull box(s) or other equipment designated by these requirements. Where Company owned transformers are to be installed in a vault or enclosure on the customers premises, the service conduit will terminate in the transformer vault or enclosure. In all other cases a terminating enclosure will be installed. All material and equipment required to be furnished and installed by the customer under the terms of this paragraph shall comply with the detailed requirements hereinafter specified and shall permanently be maintained in good order by the customer.

6.3 Service Conductors

The Company will, in all cases, determine the size, type and number of runs, of service conductors from the Company's lines to the terminating enclosure.

The Company will furnish the service conductors, together with terminations on the pole and any necessary miscellaneous materials required. The Company will install this material.

All service conductors, terminations, and miscellaneous material installed by the Company will be owned and maintained by the Company after their installation under the provisions of the foregoing paragraph.

When in the opinion of the Company, it is practicable, cable-in-conduit (CIC) will be used for the service lateral. The "service lateral" is that portion of cables or CIC or any other type of conduit and conductors, primary and/or secondary from the service arm on the pole to the customers terminating enclosure. The customer shall pay for or supply the pole mounted material as specified in [Section 6.1 \(page 3–8\)](#). The customer shall also supply the trench, backfill, paving and terminating enclosure(s). The Company will furnish, install, own and maintain the cables or CIC for the entire lateral.

When the customer's terminating enclosure is within the building, the customer shall install, own and maintain a conduit system encased in or under a minimum of 2 inches of concrete. These conduits are considered to be outside of the building per the National Electrical Code.

ESR–3	Underground Service Connections 0–600 Volts	APPROVED <i>PhH</i>
PAGE 3–8	Electrical Service Requirements ▶ SCE Public ◀	EFFECTIVE DATE 7-30-2004

7.0 Company Owned Transformers Installed on Customer's Premises

Where the Company installs transformers on the customer's premises, the customer shall furnish, as required, without cost to the Company, an easement providing adequate space for the Company's lines and transformer installation, together with their necessary appurtenances. Easements and space provisions shall be such that required clearances will be maintained between the Company's facilities and adjacent structures. This shall include adequate provisions for ingress and egress from these facilities by Company employees. The customer shall provide truck access, or other approved means for the installation and replacement of such facilities. Any vault, room, or enclosure provided by the customer shall conform with all applicable laws, ordinances, or requirements of the local inspection jurisdiction, and shall meet with the approval of the Company.

Where the Company's transformers are to be located on the customer's premises, the installation will be made by one of the following:

- In an approved transformer room, vault or outdoor walled enclosure provided by the customer at their expense.
- On a outdoor concrete pad or foundation provided by the customer at their expense, within a fenced enclosure installed on the pad.
- Pad mounted transformers, on a Pad or Slab Box, as specified in [ESR-4: Section 4.3 "Padmounted Transformers"](#).
- For further details see [ESR-4: Section ESR-4: "Company Owned Transformers on Customer's Premises"](#).

8.0 Underground Service From an Underground Source

For underground service consult the local Service Planning office for extension rules and specifications.

When in the opinion of the Company, it is practicable, cable-in-conduit (CIC) will be used for the service laterals. The "service lateral" is that portion of cables or CIC or any other type of conduit and conductors, primary and/or secondary from the Company's facilities to the customers terminating enclosure. The customer shall supply the trench, backfill, paving and terminating enclosure(s). The Company will furnish, install, own and maintain the cables or CIC for the entire service lateral.

When the customer's terminating enclosure is within the building, the customer shall install, own and maintain a conduit system encased in or under a minimum of 2 inches of concrete. These conduits are considered to be outside of the building per the National Electrical Code.

Where the Company owned transformers are installed on the customer's premises, the service conduit will terminate in a transformer vault, room, pull box or enclosure.

When it is not practicable to install CIC, the customer shall furnish and install, at their expense, a conventional service conduit system from the Company's distribution system to their terminating facilities. This will include all intermediate pull boxes or other equipment as required to deliver service.

The Company will furnish, install, own and maintain the service cables as provided for in Rule 16.

APPROVED 	Underground Service Connections 0-600 Volts	ESR-3
EFFECTIVE DATE 7-30-2004	Electrical Service Requirements ▶ SCE Public ◀	PAGE 3-9

9.0 Single Point of Service Delivery Per Building

For all single and three-phase service installations where the individual meter switch(s) are rated 200 amperes or less, only one point of service will be established. This includes single or multiple occupancy buildings (including condominiums in common tenancy and townhouses developed with common area)^{1/}, unless otherwise determined by reason of Company operating necessity. All terminating enclosures for service to each of the types, phase, and voltage classes of load to be served shall be grouped at this location. Consult the local Service Planning office for requirements.

Where Company owned transformers are to be installed on the customer's premises, see **ESR-4: Section ESR-4: "Company Owned Transformers on Customer's Premises"** for requirements.

10.0 Single Point of Service Delivery for Each Premises

One point of service delivery will normally be established for one enterprise on lots or continuous premises on which one or more buildings are to be served.^{2/} All terminating enclosures for service to each of the types, phase, and voltage classes of load to be served shall be grouped at this location.

In cases where single premises are abnormally extensive in area, the Company shall be consulted with respect to the method by which service will be supplied.

11.0 Factory Built/Modular Homes

Service to factory-built/modular homes shall be provided in accordance with the requirements for residential occupancies (stick built) constructed on site. The point of service delivery shall be designated by the Company in advance and service equipment shall be located accordingly. Where service equipment is installed at a location unacceptable to the Company, the point of service delivery shall be in a terminating pull box furnished and installed by the customer in accordance with Company requirements. When service equipment is improperly located due to the Company not being contacted prior to installation, the customer is responsible for all modifications. Consult the local Service Planning office for details.

12.0 Location of Point of Service

The location of each point of service delivery must be approved by the Company in advance of construction. The following requirements will apply:

12.1 Low voltage service (0-600 volts)

Where the Company installs underground service cable from its overhead or underground system to a point of service delivery on or in a building or structure, the point of service delivery shall be at or immediately adjacent to the building wall nearest and facing (1) the point at which the service conduit enters the premises or (2) the pole from which the service originates; and shall be as near as practicable to the corner of such wall

1/ For townhouse developments where common owned property is not available, individual services may be provided to each unit.
2/ Multiple occupancy buildings will be served by one point of service delivery unless otherwise determined by reason of Company operating necessity. See **ESR-5: Section 6.0 "Meter Locations"** for meter locations.

ESR-3	Underground Service Connections 0-600 Volts	APPROVED <i>PhH</i>
PAGE 3-10	Electrical Service Requirements ▶ SCE Public ◀	EFFECTIVE DATE 7-30-2004

which is accessible with a minimum length of service conduit. For meter locations, see [ESR-5: Section 6.0 "Meter Locations"](#). The point of service delivery may be in a sub-way type pull box between the building served and the Company's lines, provided it is in a permanently accessible location approved by the Company. All terminating enclosures shall be located as specified in [Section 15.0 "Terminating Enclosures" \(page 3-13\)](#).

Where the Company installs service cables to a point of service delivery at which the terminating enclosure is a sub-way type pull box, manhole, or the pull section of a switchboard, the terminating location shall be approved by the Company.

Where the customer takes service from a point of service delivery in a transformer vault or enclosure on the customer's premises containing Company owned transformers, The Company will designate the manner in which the customer's service entrance conductors are to be installed in the vault or enclosure.

12.2 Service (above 600 volts)

The Company will install the service cable for all high voltage services in accordance with the applicable provisions of its rules, see [Section 6.3 "Service Conductors" \(page 3-8\)](#).

The point of service delivery shall, in every case, be in a location approved by the Company either inside or outside of a building.

The service terminating enclosures shall be located in accordance with the detailed requirements for such locations, see [Section 15.0 "Terminating Enclosures" \(page 3-13\)](#).

Services above 600 volts will be treated individually as special cases. Consult the local Service Planning office for details.

13.0 Service Conduit Installations

The customer shall install all service conduit intended for the installation of Company service cables in accordance with the following requirements:

13.1 Size and number of conduits

Due to the various sizes of service cables available, contact the local Service Planning office for information relative to the minimum size and number of conduits acceptable to the Company. See [Table 3-5 \(page 3-25\)](#) for the acceptable types of conduits.

13.2 Depth of Conduit

A minimum cover is required over all service conduit installations. This cover is measured from the outside of the conduit to the finished surface grade and varies both with location and service voltage. Company minimum cover requirements are shown in [Table 3-1 \(page 3-12\)](#).

Where a conduit is stubbed out to curb or property line to be picked up later, it must terminate on a level course with sufficient depth to cross the gutter with the cover required for the service voltage application.

APPROVED 	Underground Service Connections 0-600 Volts	ESR-3
EFFECTIVE DATE 7-30-2004	Electrical Service Requirements ▶ SCE Public ◀	PAGE 3-11

Table 3-1: Conduit or Cable System Minimum Cover^(a)

Supply Cable	Conventional ^(b)	CIC
Street Lights (All Voltages) & 0-30,000 Volts		
Commercial	30 inches	45 inches ^(c)
Residential	30 inches	45 inches
30,001-35,000 Volts		
Commercial	30 inches	N/A
Residential	30 inches	N/A

- (a) See [Table 3-4 \(page 3-24\)](#) for encasement schedules.
- (b) These values are Company nominal minimum cover values. They must be increased accordingly where necessary to comply with applicable codes and ordinances and to meet joint construction requirements with other utilities.
- (c) Where CIC is installed in conduction with conventional conduit, consult the local Service Planning office for minimum conduit cover requirements.

13.3 Route of Conduit

The entire route of the conduit installation for Company use must meet with Company approval.

13.4 Maximum Length of Conduit

The maximum allowable length of conduit between pull boxes is determined by the type and size of cables, the conduit size and the number of bends in the run. The number of bends along the conduit route should be kept to a minimum to facilitate pulling of cable and to minimize the need for pulling structures. Consult the local Service Planning office for information on specific installations.

13.5 Pull Rope or Muletape in Conduit

Each conduit installed for Company use shall be provided with a pull rope or muletape for conduits up to 1,000 feet. Pull ropes shall be yellow in color, and have a minimum diameter of 1/4 inch and a minimum average tensile strength of 1,100 pounds. A tracer color (one or more yarns in a single strand) may be included to identify the manufacturer. Where the conduit is stubbed out to be picked up later, the pull rope must be secured outside the stub end of the conduit. Where the conduit is joined with an existing conduit, the pull rope must also be joined. Contact the local Service Planning office if no pull rope can be found in the existing conduit.

Neptco muletape product # WP1250P may be used in conduit runs up to 1,000 feet. For runs longer than 1,000 feet use Neptco product #WP1800P or WP2500P. The Neptco muleknot is required to tie off each end.

13.6 Bends in Conduit

See [Figure 3-4 \(page 3-23\)](#) for the minimum permissible radius of various types of riser bends in service conduits.

13.7 Inspection of Conduit

All conduit installed for Company use shall be mandreled with a Company approved mandrel to insure that it is clean and free of obstructions.

ESR-3	Underground Service Connections 0-600 Volts	APPROVED 
PAGE 3-12	Electrical Service Requirements ▶ SCE Public ◀	EFFECTIVE DATE 7-30-2004

Service conduit installations which will remain under customer ownership must meet the requirements of the Company and the local code enforcement agency having jurisdiction. Service conduit installations require Company inspection prior to backfilling. Contact the local Service Planning office at least 48 hours in advance of inspection. Any installation backfilled without benefit of this inspection will be subject to re-excavation at the customer's expense.

14.0 Service Conduit Entry Into Building Served

14.1 Residential Buildings 0–600 Volts

The service conduit shall not pass under or into the building being served, except at a distance sufficient to permit its entrance into the bottom of a terminating enclosure recess into an outer wall, see [Figure 3–18 \(page 3–37\)](#).

14.2 Commercial Buildings 0–600 Volts

The service conduit should only pass under or into the building served for the shortest practicable distance necessary to reach a terminating enclosure located in accordance with, [Section 15.5 "Wall Mounted Type Terminating Pull Boxes and Switchboard Pull Sections" \(page 3–14\)](#).

14.3 Services 2,400–16,500 Volts

The service conduit may extend into the building served to a location approved by the Company for the location of the terminating enclosure or transformer vault. The location of the point of entry of the conduit into a transformer vault will be designated by the Company. Contact the local Service Planning office for details.

15.0 Terminating Enclosures

Every service terminating enclosure shall be in a permanently accessible location which is acceptable to the Company.

Whenever a terminating enclosure is within a single occupancy building and such building is divided into a multiple occupancy, all sets of service entrance conductors shall be brought to a single terminating enclosure located as required for multiple occupancy buildings, see [ESR–5: Section 6.0 "Meter Locations"](#).

15.1 Type Required For Service 0–600 Volts

A terminating enclosure shall be provided for all underground services. Terminating enclosures shall be subway-type as shown in [Table 3–6 \(page 3–41\)](#), wall-mounted pull boxes as shown in [Figure 3–9 \(page 3–29\)](#), [Figure 3–10 \(page 3–30\)](#) and [Figure 3–11 \(page 3–31\)](#) or switchboard pull sections as shown in [ESR–6: Figure 6–7](#). Where required, terminating lugs for Company service cables will be furnished and installed by the Company.

Safety socket boxes as shown in [ESR–5: Figure 5–7](#) and [ESR–5: Figure 5–8](#), meter post and pedestals as shown in [Figure 3–23 \(page 3–42\)](#) and [Figure 3–25 \(page 3–45\)](#), and instrument transformer cabinets as shown in [ESR–5: Figure 5–13](#), are also acceptable terminating enclosures as permitted in these requirements.

Individually metered single family occupancies up to 400 amperes shall use combination meter panels with termination sections as shown in [Figure 3–6 \(page 3–25\)](#) and [Figure 3–7 \(page 3–26\)](#).

APPROVED 	Underground Service Connections 0–600 Volts	ESR–3
EFFECTIVE DATE 7-30-2004	Electrical Service Requirements ▶ SCE Public ◀	PAGE 3–13

15.2 Type Required For Service Above 600 Volts

All services above 600 volts require special terminating enclosures. See [ESR-7: Section 4.0 "Service Cable Termination Section"](#) or contact the local Service Planning office for additional information.

15.3 Subway Type Terminating Enclosures

The service entrance conduit and conductors from a subway type terminating box shall be furnished and installed by the customer.

Where an outdoor concrete subway type pull box is used as a terminating enclosure, or the supply end of the customer's service entrance conduit originates in an underground vault with outdoor access or in an outdoor transformer enclosure, the customer's service entrance conductors will normally be required to pass through a terminating type wall mounted pull box or a switchboard pull section. This will act as a water trap to prevent water or moisture from entering the termination enclosure or metering sections containing energized terminations or devices.

The Company will make the termination's in the termination enclosure between the Company's service cables and the customer's service entrance conductors.

In cases where the standard size terminating enclosures/boxes are not suitable for a particular application, special enclosures of equal or larger size may be used where specifically approved by the Company.

15.4 Subway Type Terminating Pull Boxes

Subway type pull boxes for the termination of underground services shall be installed in the ground at a permanently accessible location outside of a building between the building and the Company's lines. Such boxes shall be installed with the cover flush with the finish grade. Consult the local Service Planning office for details.

15.5 Wall Mounted Type Terminating Pull Boxes and Switchboard Pull Sections

Wall mounted service terminating pull boxes and switchboard pull sections shall be located on or recessed in an exterior wall of the building served, facing outward. The enclosure shall be permanently accessible without entering the building, shall not project into any driveway, walk, or public way and shall have access and working space in compliance with [Section 15.6 "Access to and Working Space in Front of Termination Enclosures"](#) (page 3-15). The bottom of the wall mounted enclosures shall not be less than 6 inches nor more than 5 feet above the standing and working surface.

Wall mounted type pull boxes and switchboard pull sections may be installed inside a commercial or industrial occupancy at grade floor level or may be installed in a basement having a ceiling height of not less than 7 feet. All such installations shall comply with access and working space requirements and shall meet with the approval of the Company.

Under the following conditions, and with permission of the local Service Planning office, terminating enclosure's may be located inside of a building.

The service conduit shall be encased in not less than 2 inches of concrete or under a concrete floor at least 2 inches thick.

The service conduit runs directly to the terminating enclosure, either in a straight line or in a bend of not less than 3 foot radius, and enters the enclosure at right angles to the top, back or bottom.

ESR-3	Underground Service Connections 0-600 Volts	APPROVED <i>PhH</i>
PAGE 3-14	Electrical Service Requirements ▶ SCE Public ◀	EFFECTIVE DATE 7-30-2004

There is permanent, unobstructed, 24 hour access for all equipment and material that may be required by the Company for future maintenance, repair or upgrading of the service.

Access to and work space in front of the terminating enclosure shall be provided for as outlined below.

Switchboard pull sections may be incorporated in outdoor switchgear in a location approved by the Company. The pull section shall not project into any public way and shall be located to provide clear access and working space.

15.6 Access to and Working Space in Front of Termination Enclosures

All terminating enclosures shall be provided 24 hour accessibility for installation and maintenance of the Company's facilities. Access must be through walking space affording not less than 7 foot height and 3 feet in width and be acceptable to the Company.

A permanent, level standing and working surface shall be provided. It shall be clear and unobstructed, at least equal to the width and height of the terminating enclosure space and extending not less than 3 feet in front of all terminating enclosures and their housings. In no case shall the height of the clear space be less than 6 feet 6 inches. The width shall not be less than 3 feet. Non-residential service pedestals 0-200A, [Figure 3-25 \(page 3-45\)](#) shall be located to allow 3 feet clearance for terminating enclosure in rear. Consult the local Service Planning office for details Greater clearances are required for high voltage installations.

16.0 Electric Meter Rooms

An electric meter room is an illuminated room, located inside a building provided by the customer and approved by the Company as to the location of the electric service and metering equipment. The electric meter room may be used by the customer at their option, rather than placing metering equipment on the exterior of the building. A chain link fence is not acceptable as a separating room wall. The following provisions shall apply:

16.1 Access

Access shall be through a door on the building exterior opening directly into the electric meter room that provides 24 hour access. This door should swing out of the room whenever possible. If the door swings into the room, it is to be located so it does not open into any service equipment or working space(s). When metering equipment is installed in a locked room a lock-box (provided and installed by the company) shall be permanently secured to the outer surface of the access door or immediately adjacent to the room in a permanently accessible location. The customer shall provide a key for the meter room prior to delivery of service. This key is to be housed inside the lock-box for utility access.

When meter access problems result due to metering equipment being improperly located and the Company had not approved the location, the customer at their expense will be responsible for all modifications.

If, at any time, the company determines a meter access problem exists, or may exist (i.e., fences, building additions, shrubbery, dogs, hazardous materials, etc.) the customer at their expense shall relocate the metering facilities to a new location acceptable to the Company. For single family dwellings only, an acceptable remote meter reading device may be installed. Installation of this device(s) will be made by the Company. This option is available for 100 and 200 amp residential services only.

APPROVED 	Underground Service Connections 0-600 Volts	ESR-3
EFFECTIVE DATE 7-30-2004	Electrical Service Requirements ▶ SCE Public ◀	PAGE 3-15

Due to different characteristics of a building design, could restrict meter location options. An order of preference shall be used to evaluate and approve meter/metering equipment access. This order of preference is to provide direction for Planners and Design Service Representatives in determining meter/metering equipment location.

- A. Metering facilities and related service equipment are preferred to be located on the exterior of buildings and or structures to provide immediate access.
- B. If exterior locations become unavailable, then customers may install metering facilities inside a meter closet recessed within the exterior structure wall and accessible from the exterior.
- C. The customer may install metering facilities inside a building or structure within an approved meter room. This meter room and location must be approved by the company in advance of construction. The customer shall provide an access door on the building exterior which allows access directly into the meter room. A company provided lock-box will be provided to allow company access directly into the meter room.
- D. If an access door directly into the meter room is not provided, then immediate and non-hazardous access to the meter room shall be required through entrances and areas used during normal business hours. In addition, an exterior door in close proximity to the meter room location shall also be required for installation, replacement, and maintenance of utility service entrance cables and equipment. A local telephone number shall also be readily posted for emergency access during non-business hours to electrical service equipment located within a meter room without direct exterior door access.

In certain cases, the customer may be required by the National Electrical Code (N.E.C.) to provide 2 entrances into a meter room. This is a code issue between the customer and the local authority having jurisdiction.

16.2 Doors

The entrance to an electric meter room shall be through a vertical doorway (**roll up doors are not acceptable**), not less than 3 feet wide and 6 feet 6 inches high. The door should open out and have a doorstop mechanism to keep it open and shall utilize "lever operated" hardware. Lever operated hardware is a type that permits the door to be opened from inside the room without the use of hands.

16.3 Foreign Equipment

The following equipment is not allowed in an electric meter room. Such equipment includes but is not limited to the following:

- Prohibited Equipment.
- Gas equipment, including piping.
- Water heaters/boilers, including any piping under pressure.
- Storage of any materials, liquids, etc.
- Fire and security alarms. This includes alarm systems connected to the access door that will operate when entry is made to the electric meter room.
- Wet filled batteries and battery charging equipment.
- Irrigation and sprinkler controllers.
- Standby or emergency generators.

ESR-3	Underground Service Connections 0-600 Volts	APPROVED <i>PhH</i>
PAGE 3-16	Electrical Service Requirements ▶ SCE Public ◀	EFFECTIVE DATE 7-30-2004

Exceptions

Sprinkler supply piping and heads^{3/}, when required in an electric meter room by the local fire department or building official, are acceptable. Requirements for placement and shielding of sprinkler heads will be determined by the local inspection authority.

Pipes not under pressure may be allowed in the meter room but may not extend from the floor to the structural ceiling that is above the electrical equipment.

16.4 Headroom

Shall be through a vertical doorway not less than 3 feet wide and 6 feet 6 inches high. Refer to [Section 16.2 \(page 3-16\)](#).

16.5 Illumination

The light must be controlled by an on and off switch. Timers and motion detectors are not allowed to control the meter room lighting.

16.6 Meter Clearances

All meter installations must provide minimum clearances as shown in [Figure 3-1 \(page 3-18\)](#).

3/ Only the piping and heads required for the electric meter room are allowed in this room.

APPROVED 	Underground Service Connections 0-600 Volts	ESR-3
EFFECTIVE DATE 7-30-2004	Electrical Service Requirements ▶ SCE Public ◀	PAGE 3-17

Figure 3-1: Meter Room Clearances

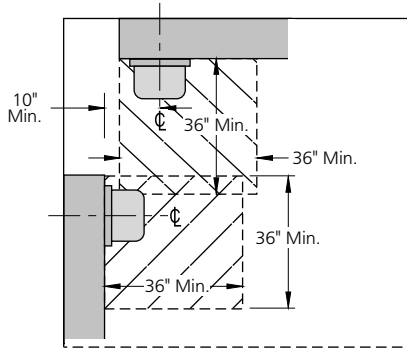

Exhibit A
Plan View

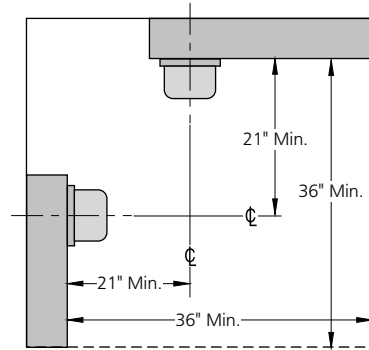

Exhibit B
Plan View

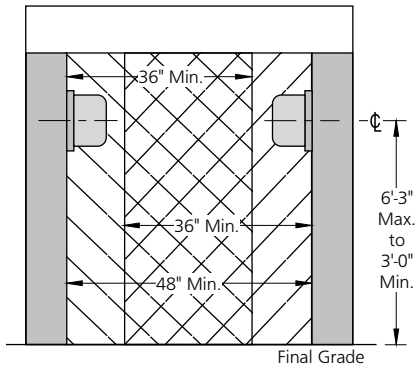

Exhibit C
Side View

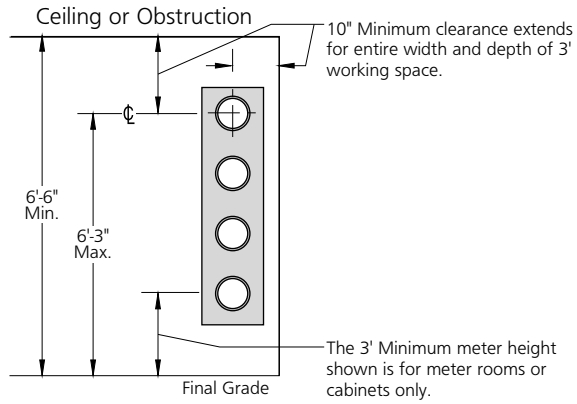

Exhibit D
Front View

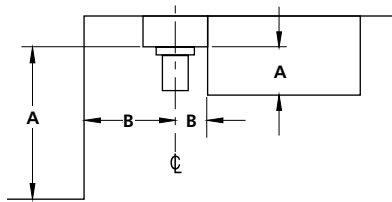

Exhibit E
Plan View

Table 3-2: Meter Room-Meter Clearances

A ^(a)	B ^(b)
0" to less than 2"	4-1/4"
2" to less than 11"	6-1/4"
11" or Over	10" Min.

- (a) A = depth of any obstruction extending beyond face of panel.
- (b) B = clearance from ϕ of socket to side obstruction.

16.7 Meter Marking^{4/}

Each meter socket, meter panel or switchboard(s) and their related meter/service disconnect shall be clearly and permanently marked by the contractor or customer to indicate the occupancy or load served. Examples of permanent marking are; (1) An identification plate secured by screws, rivets, or equivalent secure adhesive; (2) Weatherproof paint applied with stencil or legible lettering; (3) Commercially available decals. Identification means a street, apartment, or suite number. Felt pen or foreign paint is not acceptable.

16.8 Room Identification

The electrical meter room must be permanently identified "Electric Meter Room", "Meter Room" or "Electric Room".

16.9 Vehicle Access

Permanent vehicle access to the meter room is required for the installation and maintenance of service cables and metering equipment. Under some conditions, as determined by the Company, the vehicle access requirement may be waived. Consult the local Service Planning office for details.

16.10 Meter Heights

When meters are located in a meter room or when fully enclosed in a closet the minimum height of the meter(s) may be 3 feet and the maximum height shall not exceed 6 feet 3 inches. These heights are measured from the standing and working surface.

When meters are wall or surface mounted, but not located in a meter room or enclosure, the minimum height of the meter shall be 4 feet and the maximum height shall not exceed 6 feet 3 inches. These heights are measured from the standing and working surface to the center line of the meter.^{5/}

EXCEPTION: Where local ordinance dictates a maximum height requirement for equipment located in franchise areas and the minimum meter height of 4 feet can not be attained, the minimum meter height may be reduced to 3 feet for an exposed meter when a safety socket box with factory-installed test-bypass facilities is mounted and secured to the outside of an enclosure or cabinet (traffic controller, fiber optics or wireless equipment enclosures).

16.11 Working Space - Metering and Service Equipment

Working space is required to permit access to the metering and service equipment and to provide working safety for personnel. A clear level and unobstructed working and standing space entirely on the property of the customer is to be provided in front of all meters and service equipment. Service equipment is defined as any termination enclosure, metering and or disconnect device and distribution equipment required to provide service.

The working space is to be kept clear level and unobstructed. It must extend a minimum of 3 feet from the face of any and all service equipment for services of 600 volts or less. Consult the local authority having jurisdiction for higher voltage requirements.

- 4/ These requirements are for grouped meter service installations or where required for single commercial installations only. They do not pertain to single family dwellings.
- 5/ **CAUTION:** If the service equipment is installed on a house keeping pad, then the standing and working area may have to be raised and extended outward in order to maintain the maximum meter height and proper safe working space.

APPROVED 	Underground Service Connections 0-600 Volts	ESR-3
EFFECTIVE DATE 7-30-2004	Electrical Service Requirements ▶ SCE Public ◀	PAGE 3-19

For high voltage see [ESR-7: Section 6.0 "Working Space for High Voltage Switchboards"](#).

The width of the working space shall permit ready access to the complete service equipment installation and in no case be less than 3 feet.

The height clearance for the working space shall be no less than 6 feet 6 inches as measured from the clear, level and unobstructed work surface to any overhead obstruction. The working space and clearance requirements in meter rooms for 0-600 volts are illustrated in [Figure 3-2 \(page 3-21\)](#).

ESR-3	Underground Service Connections 0-600 Volts	APPROVED <i>PhH</i>
PAGE 3-20	Electrical Service Requirements ▶ SCE Public ◀	EFFECTIVE DATE 7-30-2004

Figure 3-2: Working Space and Clearance Requirements 0-600 Volts

Top View of Service Equipment

Working Space & Clearance requirements 0 - 600 Volts
(Top View of Service Equipment)

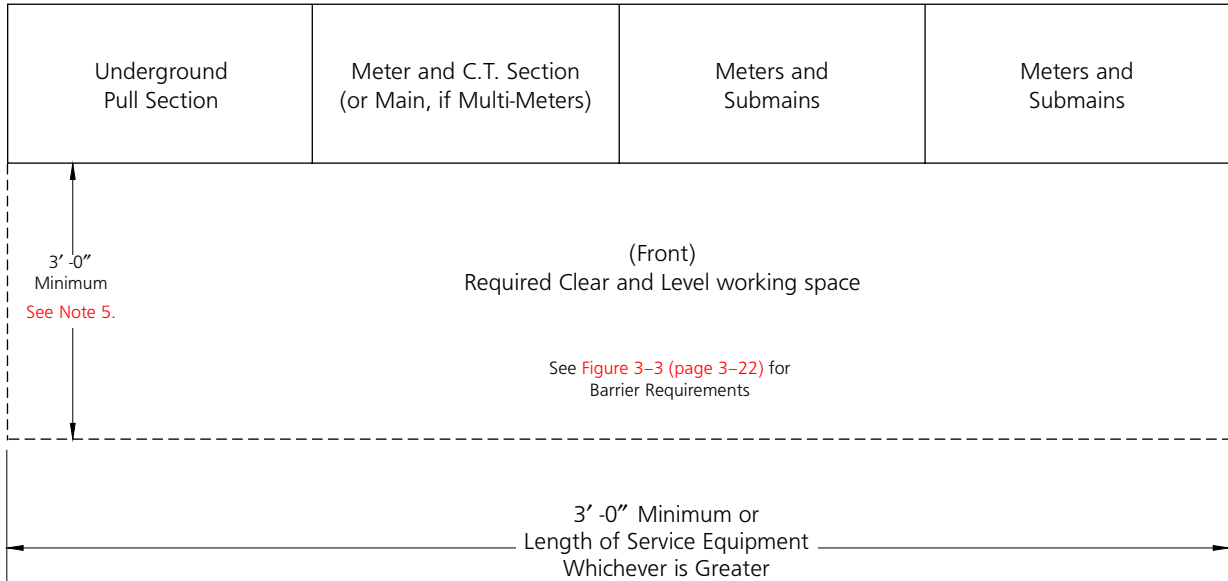

Note:

1. A minimum of 3 feet of clear, level, unobstructed work space is required in front of all termination, metering and service equipment.
2. See Section 5.0 "Metering Equipment Installations" (page 5-6) for meter mounting height requirements. Meter mounting height will be measured from the standing and working space to the center line of the meter(s).
3. When service equipment is installed on an elevated portion of the floor/ground, or "housekeeping pad", the pad shall be flush with or extend a minimum of 3 feet. This is measured from the front of the service equipment or the outer door(s) of the switchboard NEMA 3R enclosure when installed. In no case shall the maximum meter height of 6 feet 3 inches be exceeded.
4. To maintain a safe, clear and level working area in front of new or existing meter and service equipment, a concrete slab or other suitable permanent hard surface, acceptable to the Company.
5. For higher voltage service installations, contact the local authority having jurisdiction.

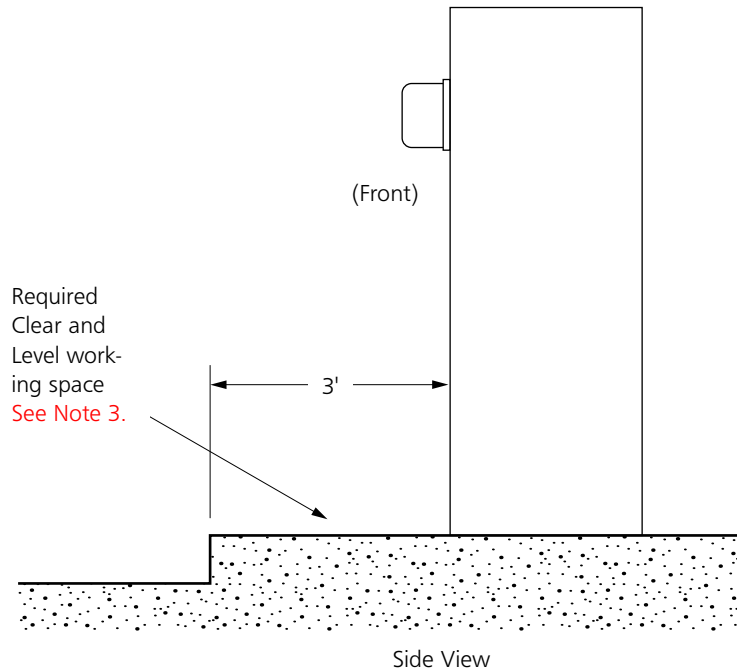

APPROVED <i>PhH</i>	Underground Service Connections 0-600 Volts	ESR-3
EFFECTIVE DATE 7-30-2004	Electrical Service Requirements ▶ SCE Public ◀	PAGE 3-21

16.12 Protective Barriers for Service Equipment

Barrier post are used to protect the meter and service equipment and personnel from vehicular contact and to prohibit encroachment into the working space. For example: loading zones, driveways, congested areas, off street parking, etc.

The customer shall provide and install "non-removable" barriers to provide the proper safe working clearances were the work space is exposed to vehicular or other hazardous conditions. Meters will not be set until the barriers have been installed.

Figure 3-3: Protective Barrier for Service Equipment Installation Requirements

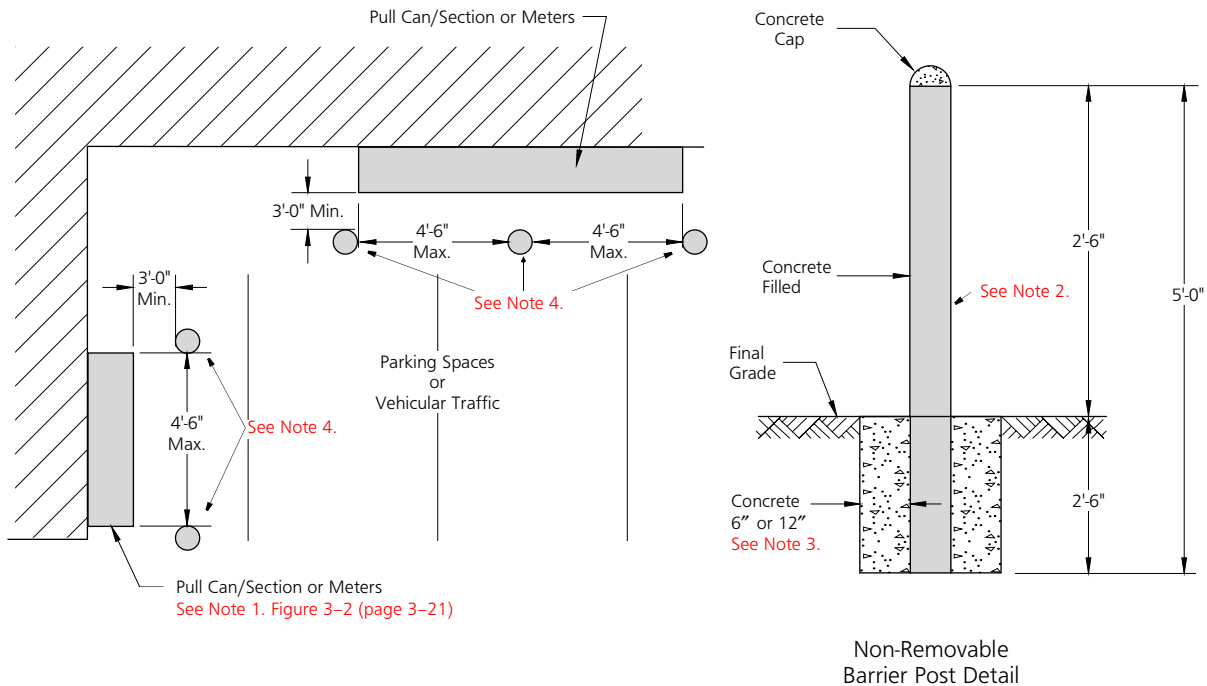

Note:

1. Meters located on a wall adjacent to any parking area or area accessible to vehicular traffic, shall be protected by non-removable barriers. Wheel stops and removable barriers are not acceptable substitutes. Maintain a minimum of 3 feet of clear and level working space in front of all the service equipment enclosures. Barriers must be so positioned as to allow all service equipment doors/panels to be opened 90 degrees.
2. Use 4 inch galvanized steel pipe (1/4 inch minimum wall) filled with concrete.
3. The concrete encasement shall be a minimum of 6 inches thick in stable soil and 12 inches thick in sandy or unstable soil.
4. Barriers must be installed in line with each end of the service equipment to prevent vehicle contact. The distance between barriers shall not exceed 4 feet 6 inches.
5. Before you excavating for the barriers, call DIG ALERT 1-800-227-2600 for markout service at least 48 hours prior to excavating.

ESR-3	Underground Service Connections 0-600 Volts	APPROVED <i>PhH</i>
PAGE 3-22	Electrical Service Requirements ▶ SCE Public ◀	EFFECTIVE DATE 7-30-2004

Figure 3-4: Typical Riser At Pole – Various Voltages

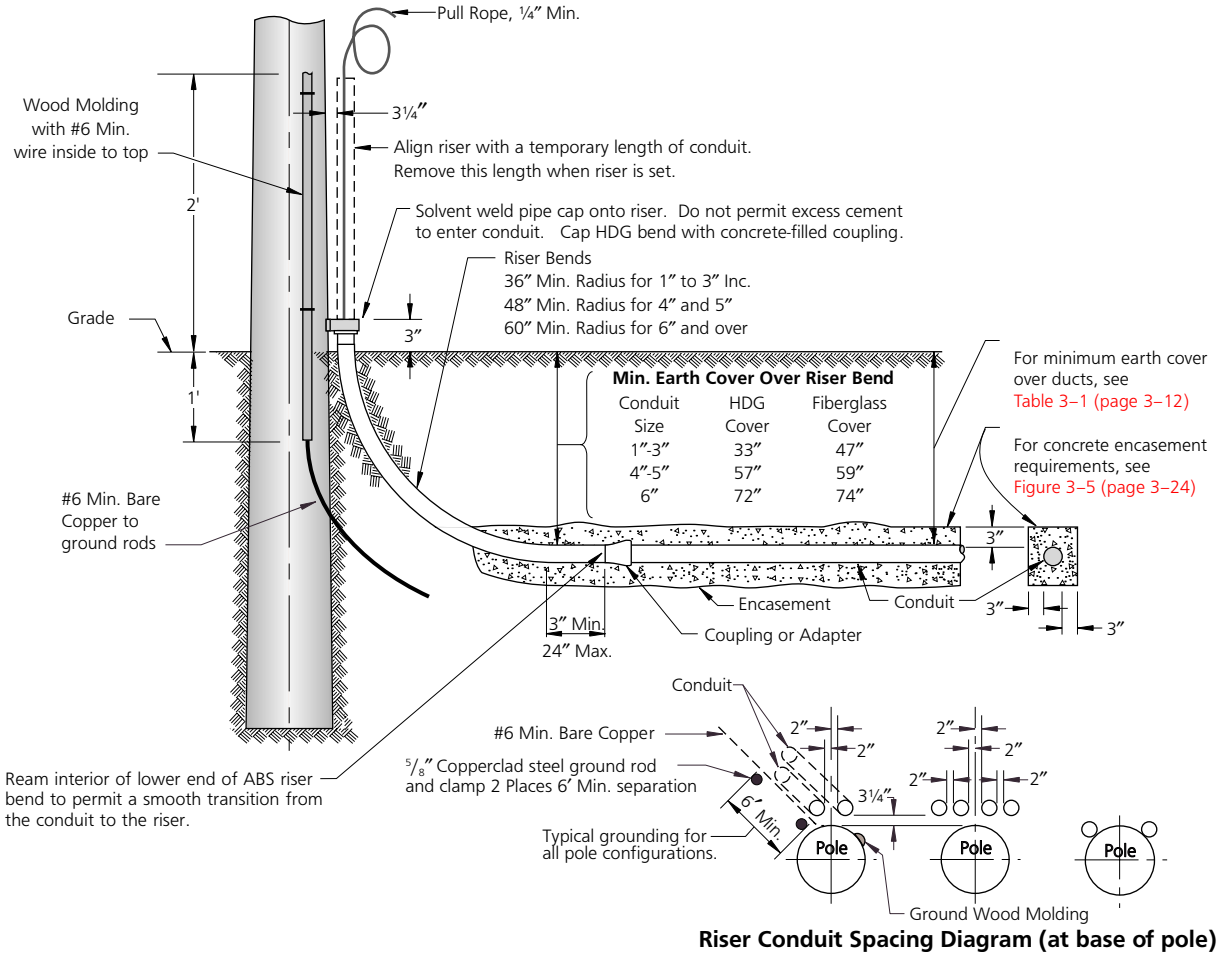

Notes

1. Approved riser bend materials and sizes are shown in Table 3-3.

Table 3-3: Approved Riser Bend Materials and Sizes

Material ^(a)	Size							
	1"	1-1/2"	2"	2-1/2"	3"	4"	5"	6"
Fiberglass	NA	NA	NA	NA	✓	✓	✓	✓
HDG	✓	✓	✓	✓	✓	✓	✓	✓

NA=Not Approved
✓=Approved

(a) Use of schedule 80 PVC is permissible when required by the local inspection authority having jurisdiction (i.e. City/County Electrical Inspection Department).

2. The Company shall designate pole and quadrant locations of riser conduits.

APPROVED <i>PhH</i>	Underground Service Connections 0-600 Volts	ESR-3
EFFECTIVE DATE 7-30-2004	Electrical Service Requirements ► SCE Public ◀	PAGE 3-23

3. Schedule 80 PVC shall be 2-1/2 inches minimum diameter extending to 8 feet above ground level. Above 8 foot, schedule 40 PVC with 2 inches minimum diameter may be used. PVC shall not be placed in the climbing space. When HDG is used, it shall be grounded unless 10 feet or more is buried in the ground. All grounding materials shall be furnished and installed by the contractor. Consult the local Service Planning office for details.
4. Prior to backfilling contact the local Service Planning office, 48 hours prior to backfilling, for an inspection.

Figure 3-5: Customer Conduit Installation and Typical Concrete Conduit Encasement

Exhibit A – Semi-Encasement

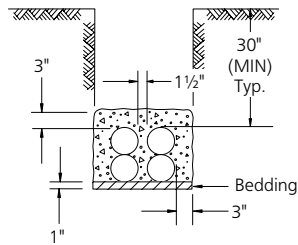
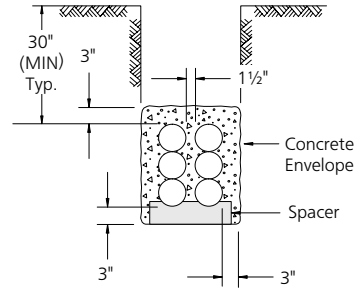

Exhibit B – Full-Encasement



Conduit Separation Schedules

Separation of 3 inches of concrete or 12 inches of earth between telephone and electric conduit is required. (Base spacers when required, shall be placed at 10 foot maximum intervals.)

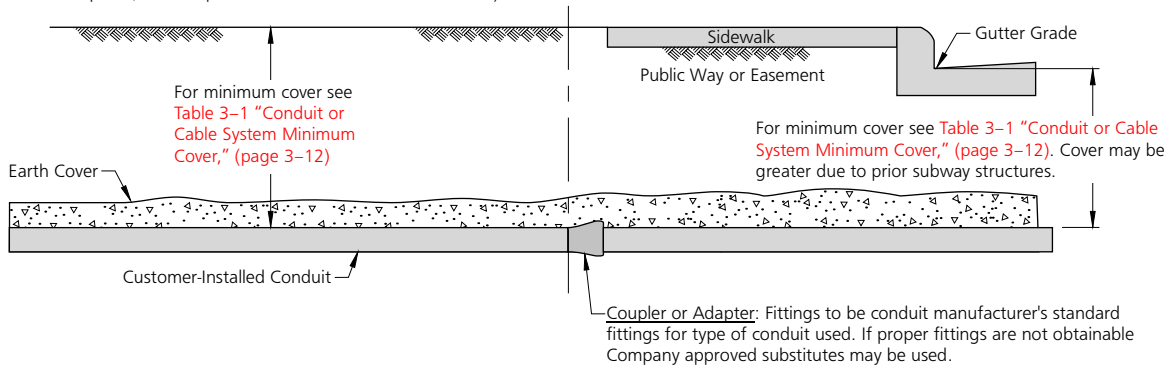

Table 3-4: Concrete Encasement Schedule^(a)

Conduit/Cable	Encasement	
	Semi	Full
Galvanized Steel Conduit	None Required	
C.I.C. Cables	None Required	
1 or 2 Direct Burial Type Conduits	None Required	
3 or 4 Conduits in a Bank, See Exhibit A Figure 3-5	✓	
More than 4 Conduits in a Bank, See Exhibit B Figure 3-5		✓

(a) Contact the local Service Planning office for encasement material specifications.

ESR-3	Underground Service Connections 0-600 Volts	APPROVED <i>PhH</i>
PAGE 3-24	Electrical Service Requirements ► SCE Public ◀	EFFECTIVE DATE 7-30-2004

Table 3-5: Edison Approved Service Conduit Material

Material ^(a)
1. Hot dipped galvanized steel (HDG). Includes intermediate metal conduit (IMC).
2. Rigid plastic polyvinyl chloride (PVC) – schedule 40 (min.) Edison approved or U.L. listed.
3. Semi-rigid plastic – DB-60, DB-100.
4. For direct buried (DB) installations – DB-60 conduit may be used for all sizes smaller than 4". DB-100 conduit is required when 4", 5", or 6" conduit is installed.

(a) Subject to approval by local inspection authorities.

Figure 3-6: Underground Combination Meter Panel 0-600 Volts

EUSER DRAWING NO. 301

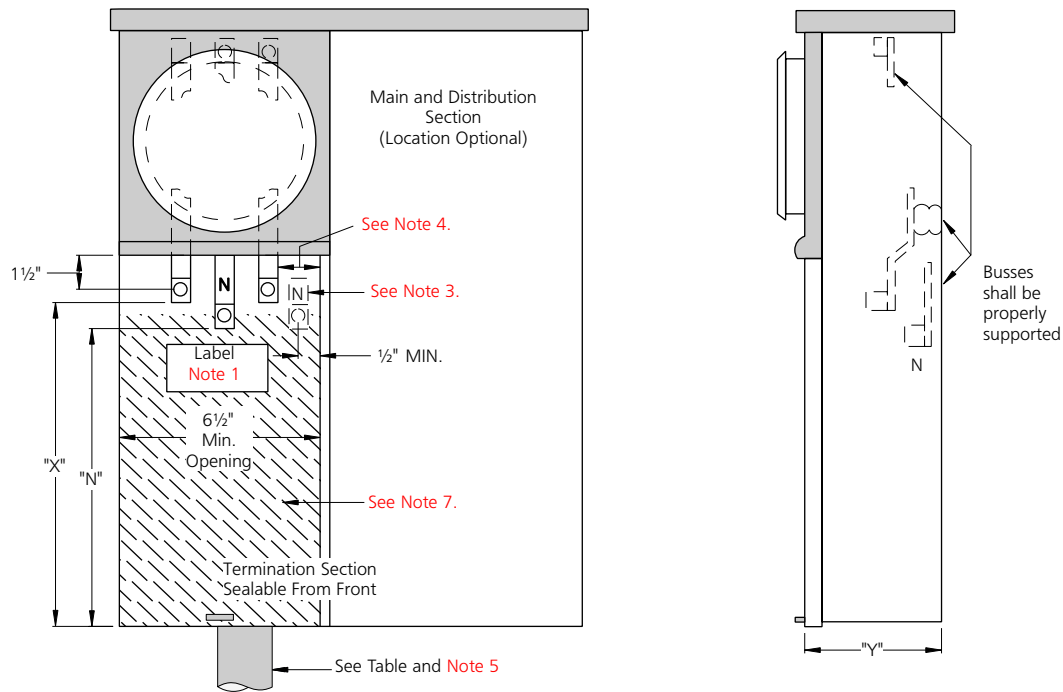

Maximum Ampacity	"X" Min. Dim.	"N" Min. Dim.	"Y" Min. Dim.	Conduit Range
125	8"	6"	4"	1 1/4" – 2 1/2"
225	11"	8 1/2"	5"	1 1/2" – 3"

Notes

1. This equipment may be constructed for overhead, underground, or for combination overhead/underground service applications. When constructed as an OH/UG device, a yellow caution label (2" x 3" minimum) shall be installed below the terminations in the pull section reading "CAUTION: BUSS ENERGIZED AT ALL TIMES".
2. Terminations for service conductors shall be aluminum bodied pressure type lugs with a range of No. 6 through 1/0 AWG for the 125 ampere device and 1/0 AWG through 250 MCM for the 225 ampere device.
3. Provide a bonding screw or jumper if the neutral terminal is insulated from the enclosure.

APPROVED <i>PhH</i>	Underground Service Connections 0-600 Volts	ESR-3
EFFECTIVE DATE 7-30-2004	Electrical Service Requirements ▶ SCE Public ◀	PAGE 3-25

4. A minimum radial clearance of 1-1/2 inches shall be provided between hot buss terminals and ground or neutral surfaces.
5. Refer to Figure 3-19 (page 3-38) for minimum conduit size and installation requirements.
6. A reducing bushing may be used when a larger conduit is required due to pulling distance or bends.
7. The shaded area of the termination section is for company service lateral conductors only.

Figure 3-7: Meter Panel for Single-Family Residential Underground Service, 300/400 Ampere (Class 320), 120/240 Volt Single Phase 3-Wire

EUSER DRAWING NO. 302A

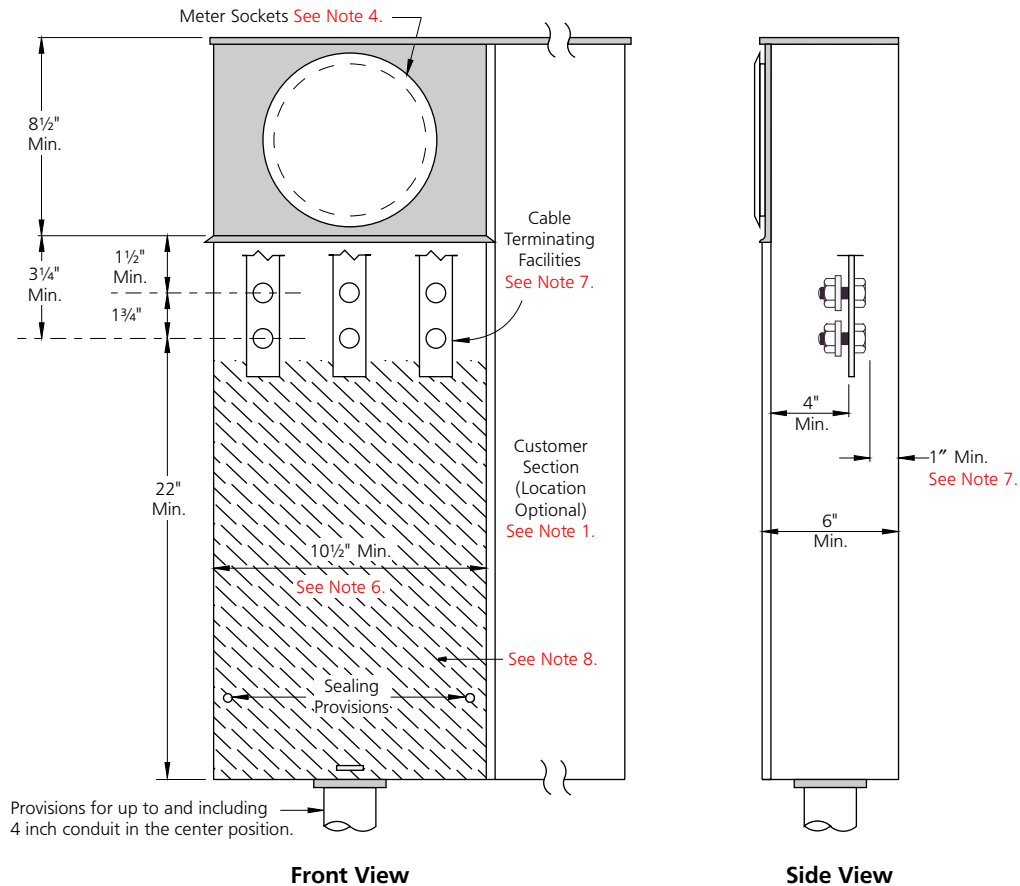

Notes

1. The panel shown is a combination device having both a utility section (i.e., termination section and metering section) and a customer section, but may also be constructed without an attached customer section.
2. The panel shall be marked with either a rating of "320 amperes continuous" or "400 amperes maximum (320 amperes continuous)".
3. Only ring type sockets are acceptable. Ring-type socket meter panels shall be provided with a sealing ring and the meter socket shall be rigidly mounted on a support and attached to the meter panel.
4. The meter socket may be located above, to the left, or right of the terminating pull section.
5. Termination section cover panels shall be removable, sealable, provided with two lifting handles, and limited to a maximum size of 9 square feet in area.
6. The access opening dimension shown (10-1/2 inches) is measured between the return flanges.

ESR-3	Underground Service Connections 0-600 Volts	APPROVED <i>PhH</i>
PAGE 3-26	Electrical Service Requirements ▶ SCE Public ◀	EFFECTIVE DATE 7-30-2004

7. Cable terminating facilities shall consist of single-position studs with clearance and access requirements complying with **Figure 3-9 (page 3-29)**.^{6/}
8. The shaded area of the termination section is for company service lateral conductors only.

Figure 3-8: Underground Service Terminating Facilities for Residential Multiple Occupancy Service — 6 Meters Single Phase 3-Wire, 0-600 Amps, 0-600 Volts

EUSER DRAWING NO. 342

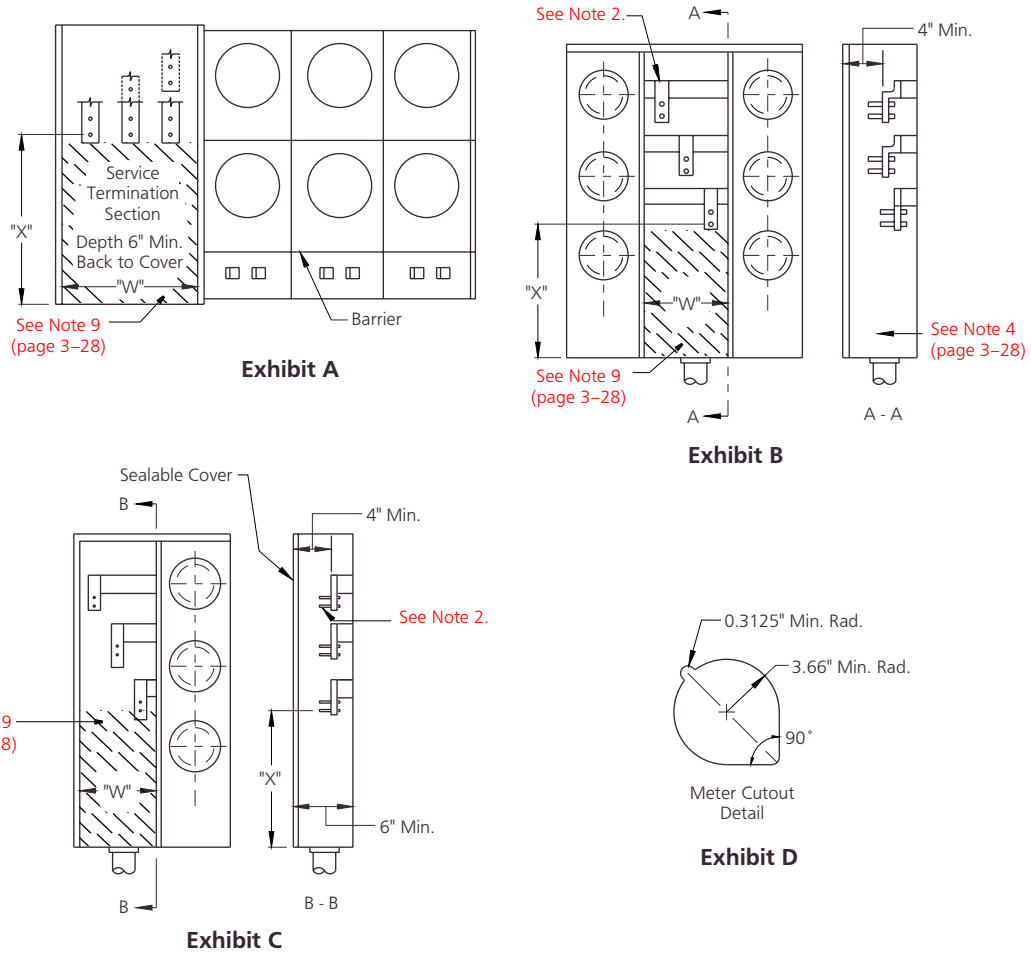

Typical Arrangement For Underground Service Terminating Facilities

Equipment Rating	"X" Dimension	"W" Dimension
0-200 Amps	11" Min.	6½" Min.
201-600 Amps	22" Min.	10½" Min.

6/ Exception: The neutral clearance to the back wall of the enclosure may be reduced.

APPROVED <i>PhH</i>	Underground Service Connections 0-600 Volts	ESR-3
EFFECTIVE DATE 7-30-2004	Electrical Service Requirements ► SCE Public ◀	PAGE 3-27

Notes

1. Termination enclosure covers shall be:
 - a. Independent of other service equipment and removable without disturbing adjacent panels.
 - b. Sealable, provided with two lifting handles, and be limited to 9 square feet in area.
2. Terminating facilities for service supply conductors shall be provided as follows:
 - a. For equipment rated 200 amperes, terminations may be aluminum bodied, pressure-type lugs with a range of 1/0 AWG through 250 KCMIL.
 - b. For equipment rated 201–600 amperes, terminations shall be single-position studs complying with **Figure 6–6 (page 6–12)**. The Company will furnish and install compression lugs on services rated above 200 amperes.
3. The neutral terminating position shall be identified.
4. Where service supply conductors cross over horizontal bussing, the buss shall be barriered or fully insulated. The shaded space shown in the terminating enclosure is reserved for Company service lateral conductors only.
5. Meter panels shall be removable to provide access to the customer’s equipment with the Company’s meters and tamper proof rings in place. Where there is more than one meter socket per panel, the minimum cutout opening as detailed in Exhibit D **Figure 3–8 (page 3–27)** shall apply.
6. Dimension “W” is the minimum access opening for the terminating enclosure.
7. Three-inch conduit is the minimum acceptable size. If air conditioning loads are served, a four inch minimum conduit is required.
8. Refer to **Figure 3–19 (page 3–38)**, **Figure 3–20 (page 3–39)** and **Figure 3–21 (page 3–40)** for installation of exposed conduits or conduits installed in a wall.
9. The shaded area of the termination section is for company service lateral conductors only.

ESR–3	Underground Service Connections 0–600 Volts	APPROVED <i>PhH</i>
PAGE 3–28	Electrical Service Requirements ▶ SCE Public ◀	EFFECTIVE DATE 7-30-2004

Figure 3-9: Underground Pull Box Equipped with Cable Terminations for Commercial or Residential use 0-600 Volts, 0-1,200 Amps

EUSER DRAWING NO. 343

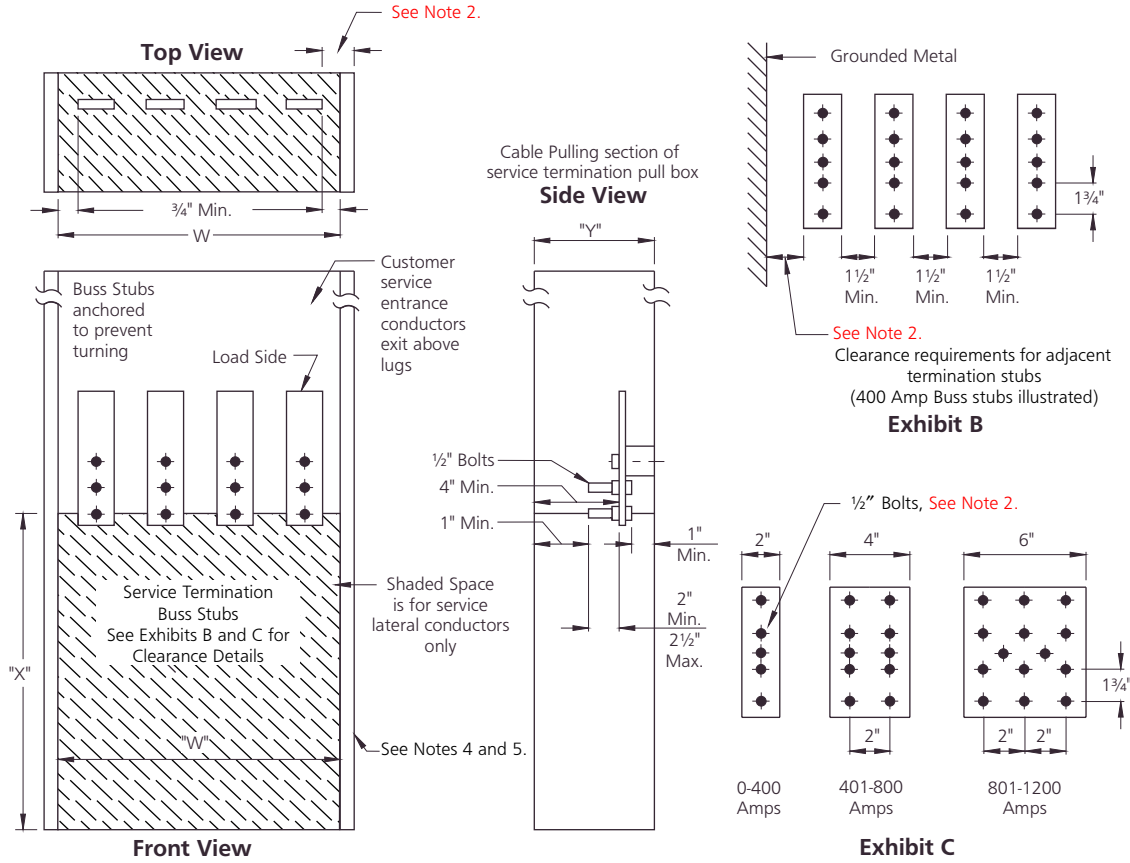

Exhibit A Minimum Pull Box Dimensions

Service Ampacity	"W" See Note 5.		"Y" Depth (in)	"X" Height (in)	Recommended Box Height "Z" (in)
	3-Wire (in)	4-Wire (in)			
201-400	10-1/2	14	6	22	36
401-800	16-1/2	22	11	26	48
801-1,200	22-1/2	30	11	26	48

Notes

1. The above dimensions are for the case where the conduit enters the bottom of the pull box and all load conductors exit above the terminals. Where the service conduit enters from the side or back of the pull box the "X" dimensions shall be taken from the closest portion of the conduit to the nearest termination bolt.
2. See ESR-6: Figure 6-6 for minimum termination clearances and for termination buss and bolt details.
3. Pull box covers shall be removable, sealable, provided with two lifting handles, and limited to a maximum size of 9 square feet in area.
4. Clear working space shall be maintained. Return flanges shall not intrude into the shaded space.
5. Dimension "W" is the minimum width of the pull box access opening.
6. Consult the local Service Planning office for conduit requirements.

APPROVED <i>PhH</i>	Underground Service Connections 0-600 Volts	ESR-3
EFFECTIVE DATE 7-30-2004	Electrical Service Requirements ► SCE Public ◀	PAGE 3-29

**Figure 3-10: Combination Disconnecting Device and Terminating Enclosure
0-600 Volts, 1,200 Amperes Maximum**

EUSER DRAWING NO. 315

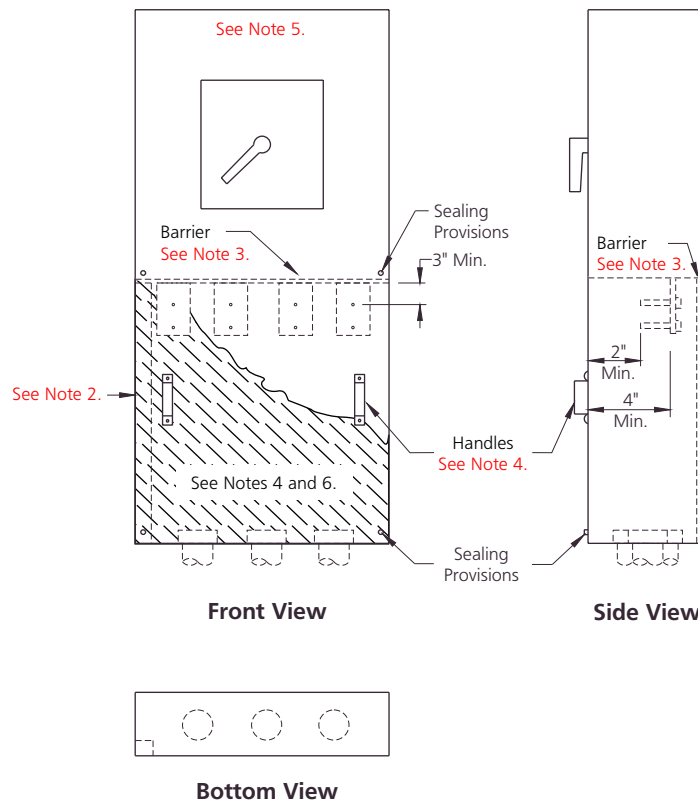

Notes

1. A vertical clearance of 3 inches minimum shall be maintained between the center line of the top bolts of the terminating facilities to any obstruction. See Figure 3-9 (page 3-29) for terminating enclosure dimensions, and terminating facility clearances and construction details.
2. The grounding electrode conductor may be installed in a fully enclosed, factory installed wireway located in either back corner of the pull box. The raceway shall not impede the required working space or reduce any specified clearances.
3. A full width and depth, insulated, rigid barrier shall be provided to separate the termination and main disconnect device compartments.
4. Terminating enclosure covers shall be:
 - a. Independent of other equipment and removable without disturbing adjacent panels.
 - b. Sealable, and provided with two lifting handles, and limited to a maximum of 9 square feet in area.
5. The main disconnect cover shall be sealable.
6. Shaded space is for service lateral conductors only.

ESR-3	Underground Service Connections 0-600 Volts	APPROVED <i>PhH</i>
PAGE 3-30	Electrical Service Requirements ▶ SCE Public ◀	EFFECTIVE DATE 7-30-2004

Figure 3-11: Underground Pull Boxes

EUSER DRAWING NO. 344

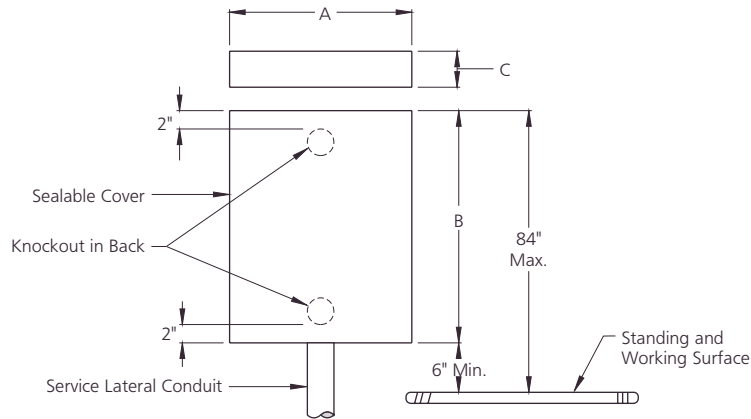

Pull Box Dimensions

Service Conduit Size	A	B	C
2" (a)	10" 8"	12" 18"	4" 4"
2½" (a)	12" 8"	16" 18"	6" 6"
3"	16"	24"	8"

(a) Normally not used for conventional conduit systems. Consult local Service Planning office.

Notes

1. The service conduit may enter the end or the back within 2 inches of the end of the pull box but shall not enter the side.
2. When a service conduit enters the end of a pull box the opposite end shall not be less than 24 inches from any side wall, ceiling, or other obstruction. Any projection which extends more than the depth of the box from the surface on which the box is mounted shall be considered an obstruction.
3. No conductors other than service conductors shall be installed in any pull box.
4. Provide two lifting handles on pull box covers of 4 square feet or more in area; covers not to exceed 9 square feet.
5. Pull box covers shall be provided with a means of sealing consisting of two drilled stud and wing nut assemblies on opposite sides of the cover. All securing screws shall be captive.
6. Consult the local Service Planning office for conduit requirements.
7. Refer to [Figure 3-9 \(page 3-29\)](#) for larger pull boxes equipped with termination facilities.

APPROVED <i>PhH</i>	Underground Service Connections 0-600 Volts	ESR-3
EFFECTIVE DATE 7-30-2004	Electrical Service Requirements ▶ SCE Public ◀	PAGE 3-31

Figure 3-12: Typical Service Lateral Installation for Single Family Residence

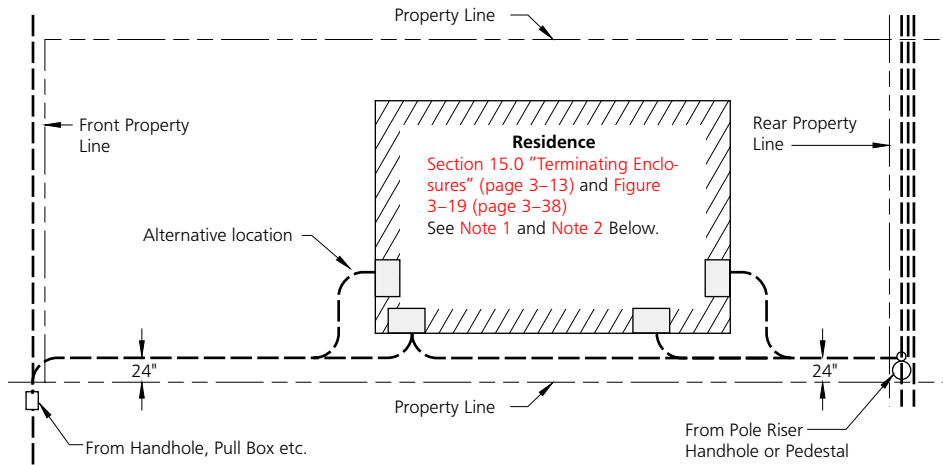

Notes

1. When a residence is served from a front property line, the customer's service equipment shall be located as shown above (front portion of residence). When served from the rear property line, the service equipment shall be located as directed by the Company representative to provide maximum accessibility for maintenance and meter reading.
2. Contact the Company local Service Planning office before locating service equipment. When service equipment is improperly located because the Company was not contacted in advance, the customer is responsible for all modifications.
3. Customers responsibility for installation of Cable-In-Conduit (CIC).
 - a. The service entrance for cable-in-conduit shall be installed as shown in [Figure 3-19 \(page 3-38\)](#) of these requirements.
 - b. The customer is to provide the trench and backfill. The trench is to be a minimum of 12 inches wide and deep enough to provide 45 inches of cover over the cables. Before cables are installed, the trench must be open and clear of all obstructions from the service entrance at the house to the riser pole, or underground system.
4. Refer to [ESR-5: Table 5-2 "Prohibited Meter Locations"](#) for meter access and prohibited meter locations.

<p>ESR-3</p>	<p>Underground Service Connections 0-600 Volts</p>	<p>APPROVED <i>PhH</i></p>
<p>PAGE 3-32</p>	<p>Electrical Service Requirements ▶ SCE Public ◀</p>	<p>EFFECTIVE DATE 7-30-2004</p>

Figure 3-13: Typical Service Conversion From Overhead to Underground

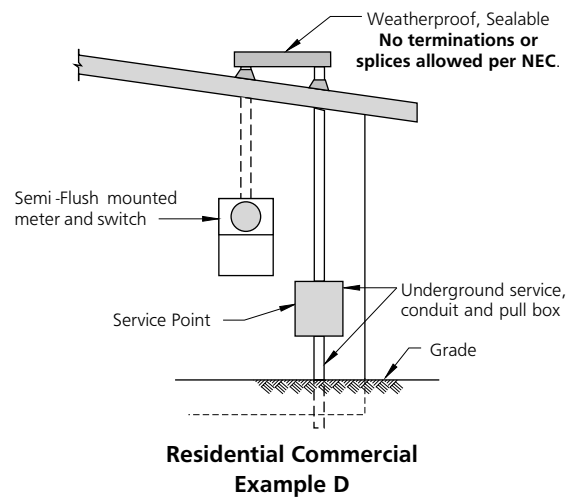
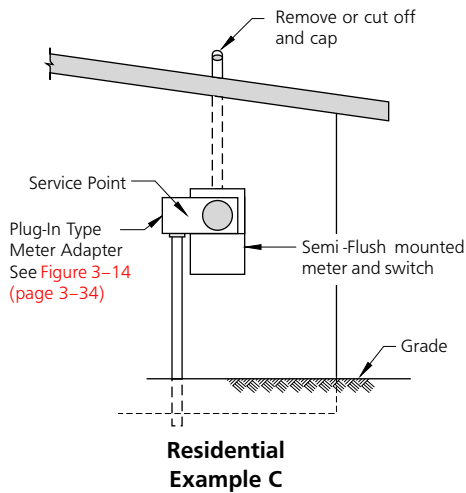
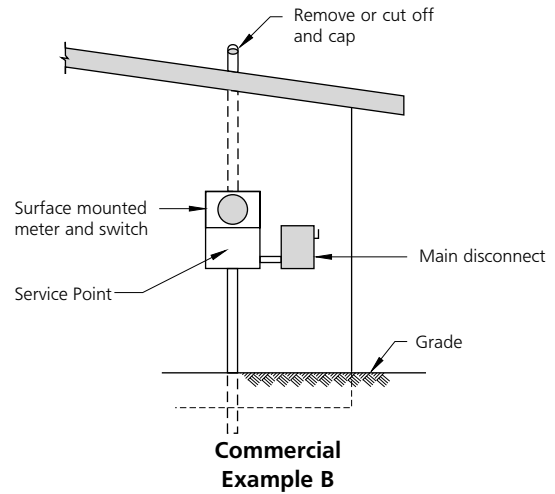
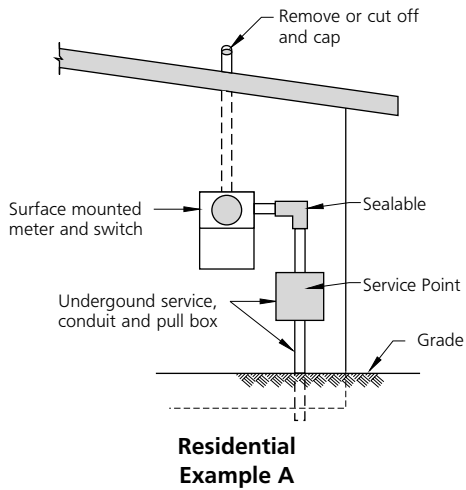

Notes

1. Customer to furnish conduits pull boxes, adapters, gutters, trench and backfill.
2. Conduits may be stubbed-up by utility for customer pick-up.
3. Exposed PVC conduit, where acceptable to local inspection agency, shall be minimum schedule 40. Were exposed to physical damage, install schedule 80.
4. Weatherhead to weatherhead conversion requires local city, county inspection, jurisdiction approval. Pull-Box shall be grounded by the customer.

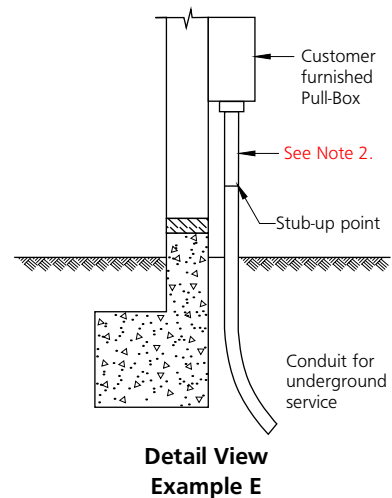

APPROVED <i>PhH</i>	Underground Service Connections 0-600 Volts	ESR-3
EFFECTIVE DATE 7-30-2004	Electrical Service Requirements ▶ SCE Public ◀	PAGE 3-33

Figure 3-14: Myers Plug-In-Type Meter Adapter

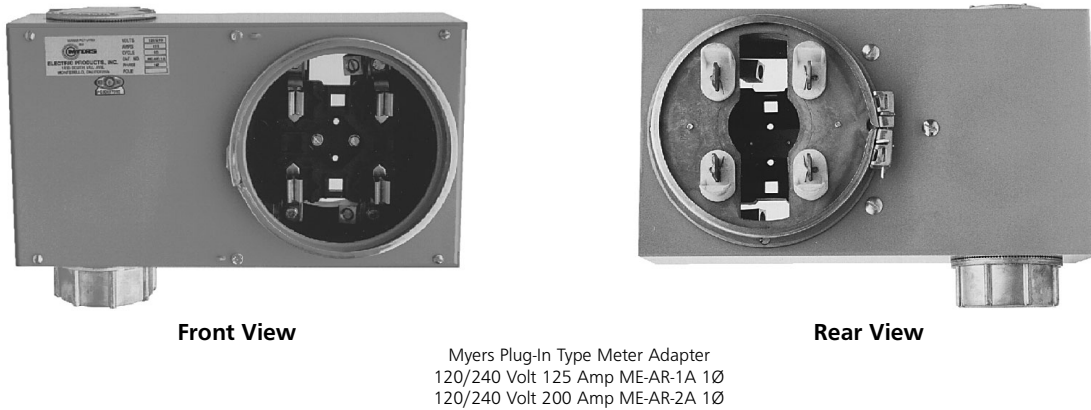
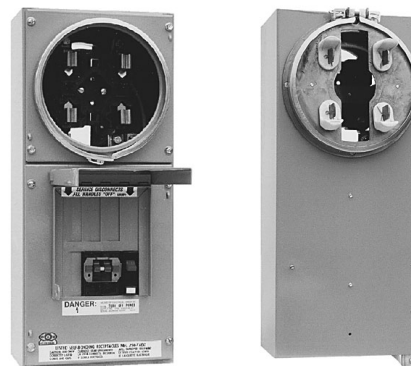
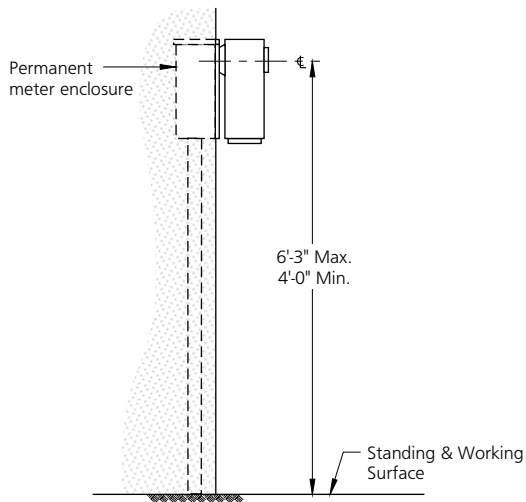

Figure 3-15: Plug-In Temporary (Piggy Back) Service Adapter



Typical Plug-In Adapter

Note

1. Permanent service cables must be installed, and approved by the local inspection jurisdiction, before a temporary (Piggy Back) service adapter may be installed.

ESR-3	Underground Service Connections 0-600 Volts	APPROVED <i>PhH</i>
PAGE 3-34	Electrical Service Requirements ▶ SCE Public ◀	EFFECTIVE DATE 7-30-2004

Figure 3-16: Temporary Service From A Padmount Transformer

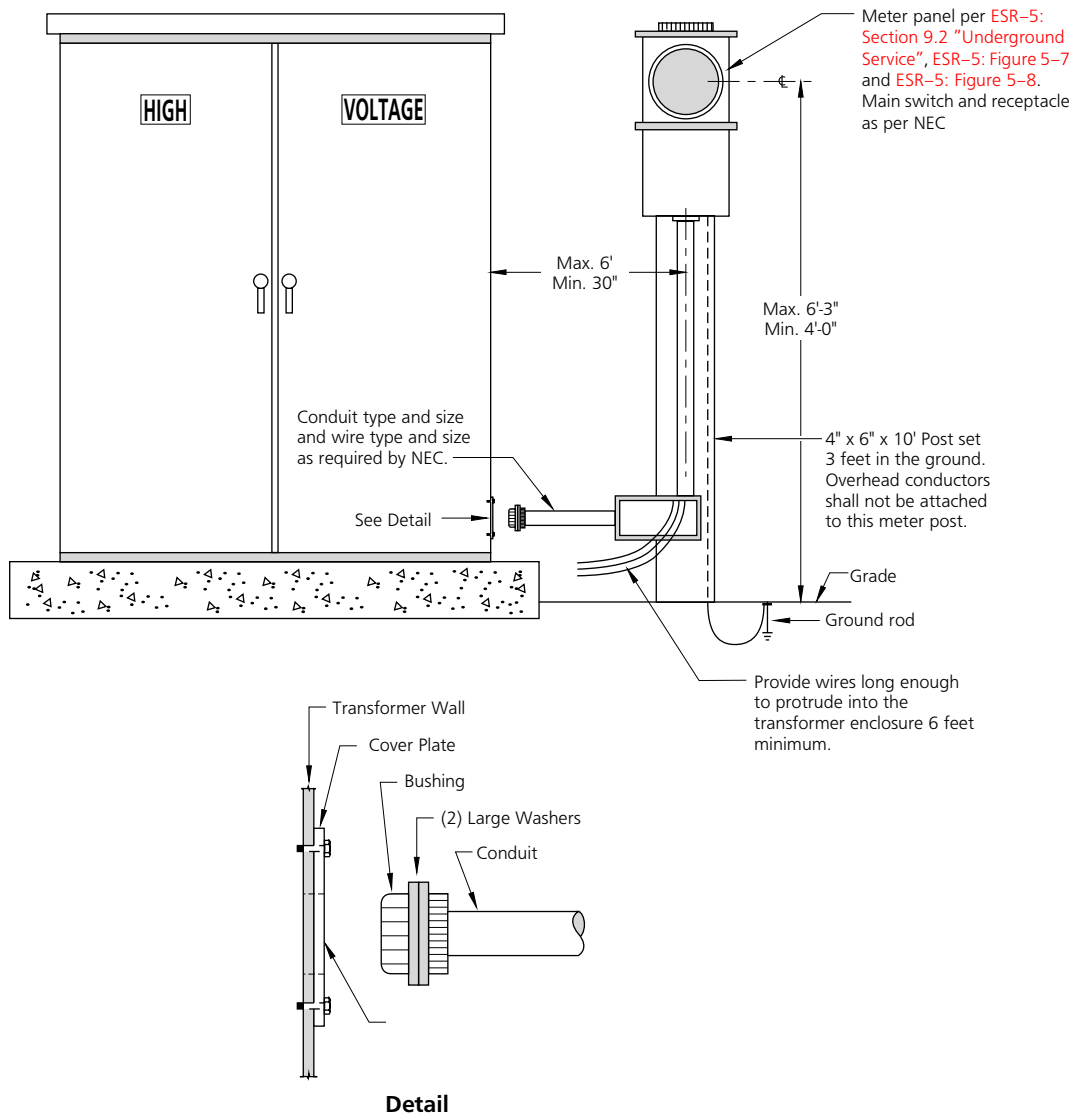

APPROVED 
EFFECTIVE DATE 7-30-2004

Underground Service Connections 0-600 Volts
Electrical Service Requirements ▶ SCE Public ◀

ESR-3
PAGE 3-35

Figure 3-17: Temporary Service From Secondary Hand Hole, Pull Box or Pedestal

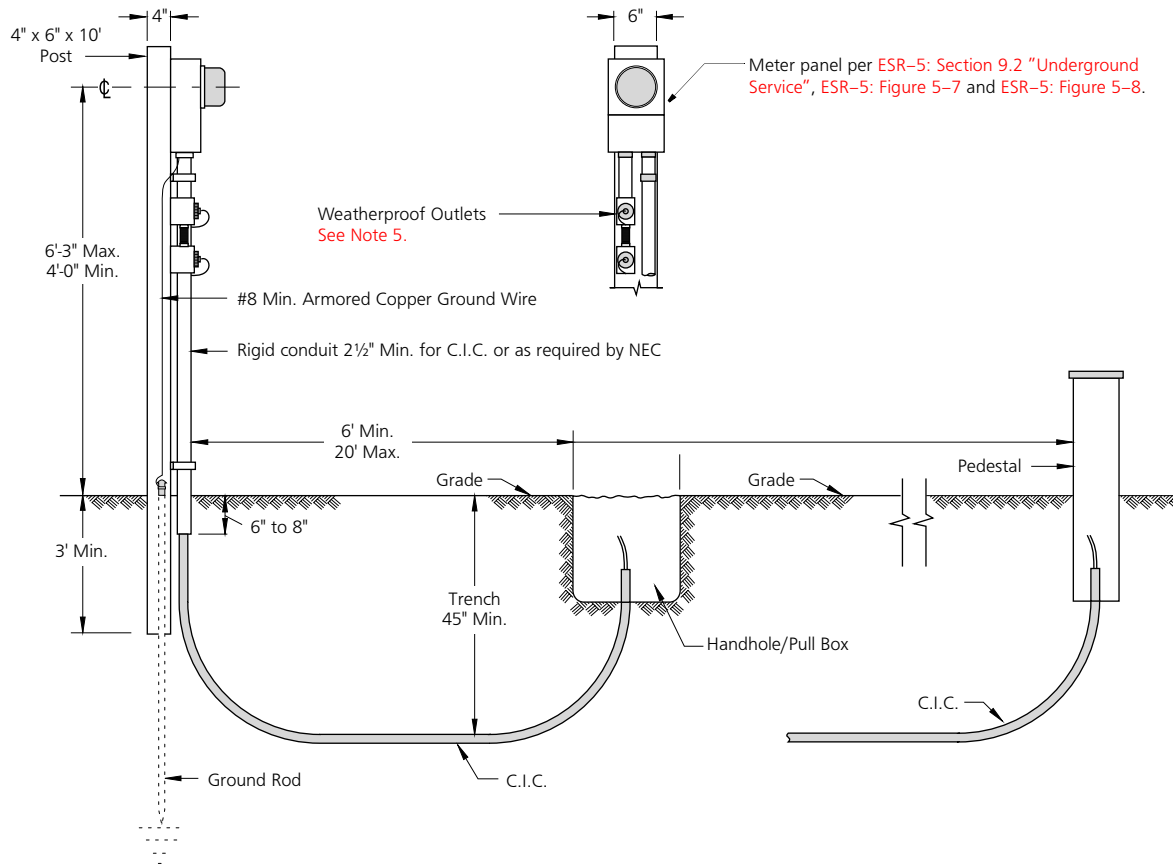

Notes

1. The Company will furnish, install and connect the cables, between the meter and the pedestal/handhole. Wire may be provided by the customer at their option. The Company will make connections at the service point.
2. Customer to furnish trench, backfill and all service equipment.
3. Set post a minimum of 18 inches from main secondary cable trench.
4. Overhead conductors shall not be attached to this meter post.
5. Refer to local inspection agency and the NEC for main switch and ground fault circuit protection requirements.

ESR-3	Underground Service Connections 0-600 Volts	APPROVED <i>PhH</i>
PAGE 3-36	Electrical Service Requirements ▶ SCE Public ◀	EFFECTIVE DATE 7-30-2004

Figure 3-18: Riser Bend for Multi-Family Residential Service Entrance, and (Recessed Service Applications)

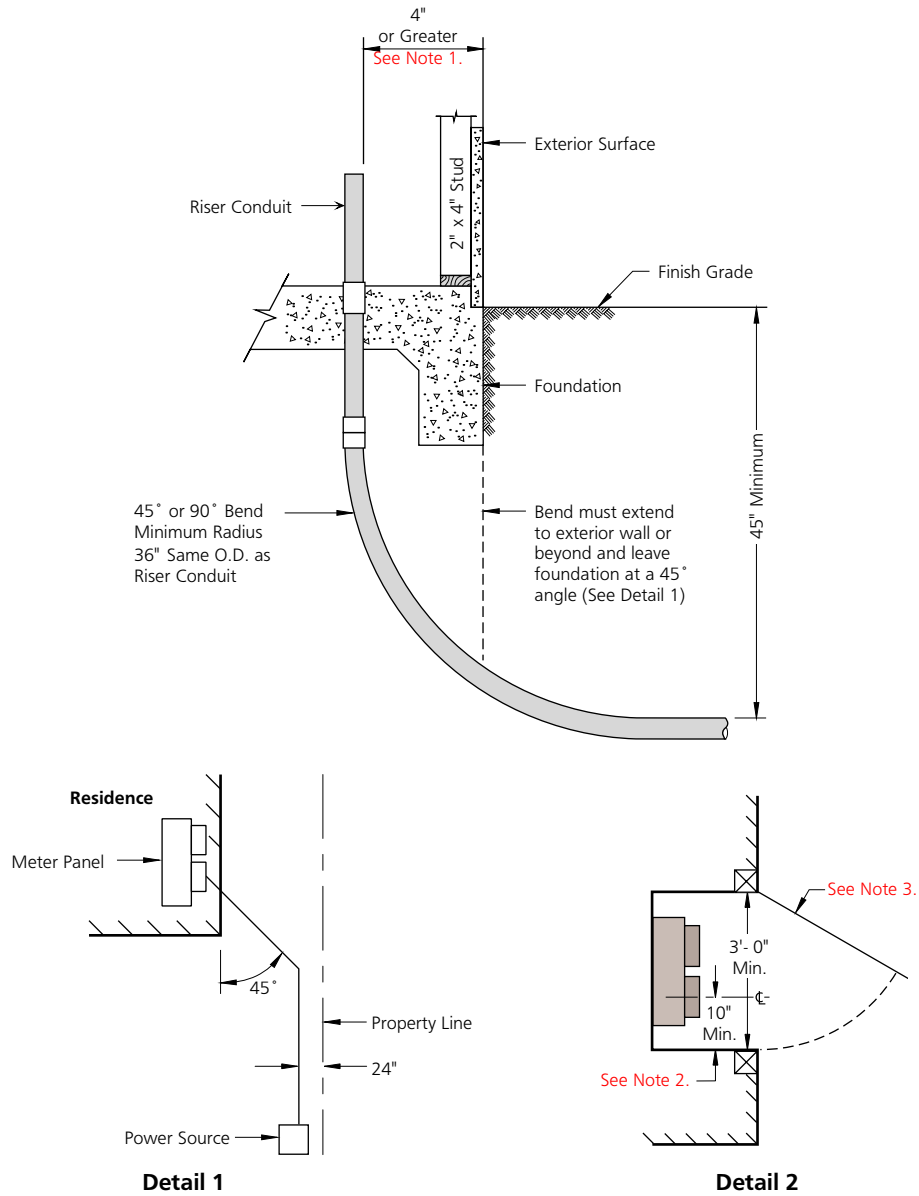

Notes

1. A bend must be permanently installed by the developer at the service entrance if the riser is recessed behind the outer wall or if the concrete foundation is poured in such a way as to effectively cause the riser to be recessed 4 inches or more. bends may be of HDG or PVC conduit as approved by the local inspection agency.
2. A 10 inch side clearance is required measured from the center line of the meter(s) to any obstruction.
3. The exterior door must open a minimum of 90 degrees.

APPROVED <i>PhH</i>	Underground Service Connections 0-600 Volts	ESR-3
EFFECTIVE DATE 7-30-2004	Electrical Service Requirements ▶ SCE Public ◀	PAGE 3-37

Figure 3-19: Service Entrance for Single Family Dwelling Service

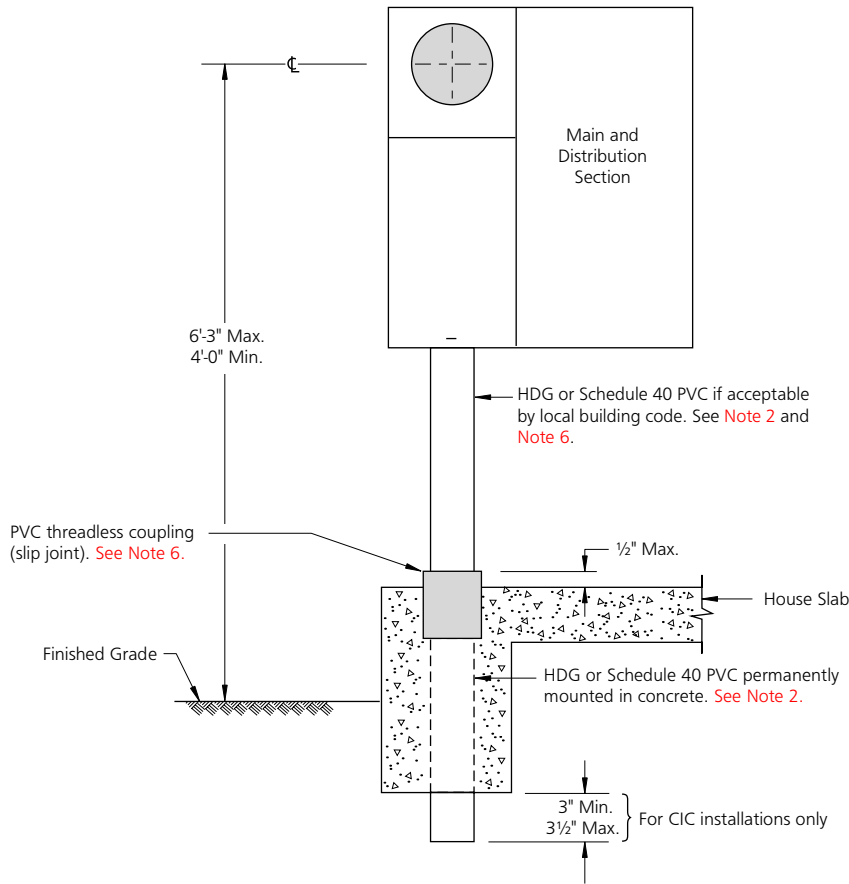

Notes

1. Customer's service conduit installation is subject to the approval of the local inspection agency. Backfill and compaction shall comply with all local ordinances.
2. Consult the local Service Planning office to determine whether Ridge Conduit or Cable-In-Conduit (CIC) cable will be installed. The local Service Planning office shall be consulted to determine minimum conduit sizes required.
 - a. *Rigid Conduit.* The minimum conduit size is 2 inches.
 - b. *Cable-In-Conduit.* The minimum conduit size for CIC is 2-1/2 inches.
 - c. Two hundred (200) ampere and larger services may require use of a larger conduit size.
3. A multiple meter service may require larger conduit than specified in Note 2, consult the local Service Planning office for details.
4. If installing CIC and soil is not "rock free" (able to pass through a 1/2 inch screen), the customer shall place 3 inches of sand beneath the cable and 6 inches of sand over the top.
5. The conduit may be HDG, or where approved by the local inspection agency, minimum Schedule 40 PVC. See Figure 3-20 (page 3-39) for exposed conduit.
6. The conduit may be installed in one piece without a coupling or in two pieces with a threadless coupling permanently mounted in the foundation as illustrated.
7. The minimum cover over CIC service conduit is 45 inches.

ESR-3	Underground Service Connections 0-600 Volts	APPROVED 
PAGE 3-38	Electrical Service Requirements ▶ SCE Public ◀	EFFECTIVE DATE 7-30-2004

Figure 3-20: Exposed Service Conduit Installation

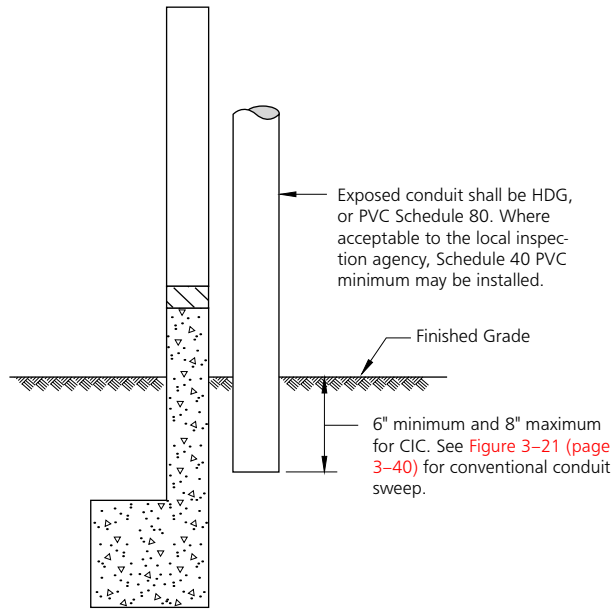

APPROVED 	Underground Service Connections 0-600 Volts	ESR-3
EFFECTIVE DATE 7-30-2004	Electrical Service Requirements ▶ SCE Public ◀	PAGE 3-39

Figure 3-21: Riser Bend Installation at Wall or Pad

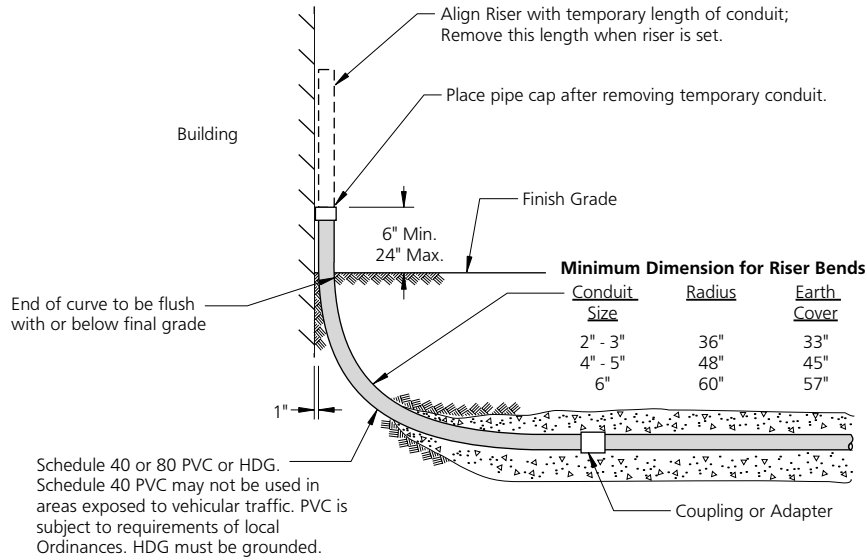

Typical Riser at Building

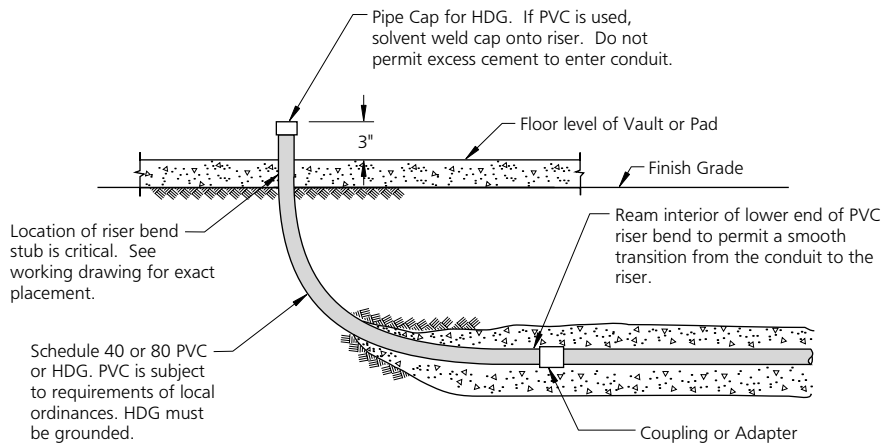

Typical Riser at Vault or PAD

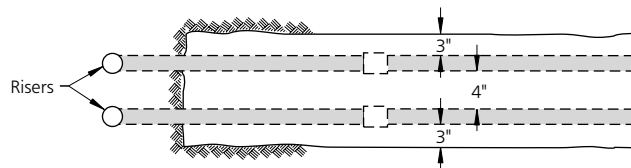

Plan-View For Two Conduit Terminals

ESR-3	Underground Service Connections 0-600 Volts	APPROVED <i>PhH</i>
PAGE 3-40	Electrical Service Requirements ▶ SCE Public ◀	EFFECTIVE DATE 7-30-2004

Figure 3–22: Handholes, Pull Boxes and Manholes

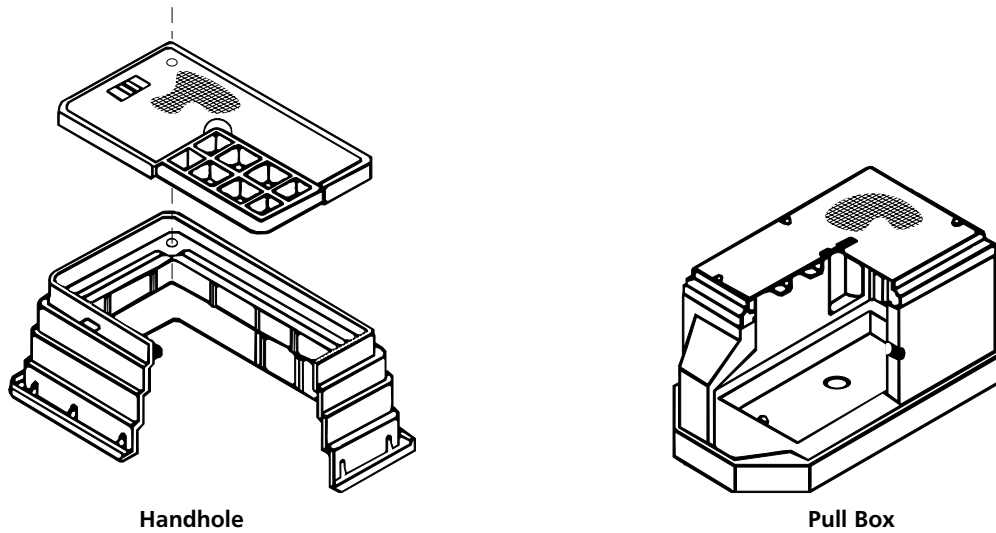

Table 3–6: Handhole, Pull Box and Manhole Application and Size

Substructure	Material	Typical Application	Inside Dimensions W x L x D	Edison Underground Structures Reference Drawing
Handhole	Plastic	Residential Service	13" x 24" x 15"	UGS-200, HH-5
Handhole	Plastic	Residential	17" x 30" x 15"	UGS-200, HH-6
Pull Box	Concrete	Residential/Commercial	2' x 3' x 3'	UGS-215.1 & UGS-215.2
Pull Box	Concrete	Residential/Commercial	2-1/2' x 4' x 3-1/2'	UGS-220.1 & UGS-220.2
Pull Box	Concrete	Residential/Commercial	3' x 5' x 4'	UGS-215.1 & UGS-215.2
Manhole	Concrete	Residential/Commercial	Consult Local the Local Service Planning Office	

Notes

1. Manholes, pull boxes and some sizes of handholes are available in precast concrete. Some handhole sizes are also available in plastic. For approved manufactures and other specifications refer to the appropriate Underground Structures Manual pages listed in [Table 3–6](#).
2. Consult the local Service Planning office for substructure details, and installation and inspection requirements. See [Section 13.7 "Inspection of Conduit" \(page 3–12\)](#).
3. Substructure covers must be adequate for imposed loading. Traffic-type covers are required in areas accessible to vehicles. Pull Box and Handhole covers shall be furnished with penta-head stainless steel cap screws. All covers shall be identified with a 1/2 inch block lettered "EDISON."
4. Dimensions are inside measurements and are shown in order of width, length and depth. Depths shown are minimum dimensions with required depth depending on the number of conduits and conduit cover.

APPROVED 	Underground Service Connections 0–600 Volts	ESR–3
EFFECTIVE DATE 7-30-2004	Electrical Service Requirements ▶ SCE Public ◀	PAGE 3–41

**Figure 3-23: Typical Mobile Home or Residential Service and Meter Post
Maximum 200 Amps 120/240 Volts**

EUSER DRAWING NO. 307

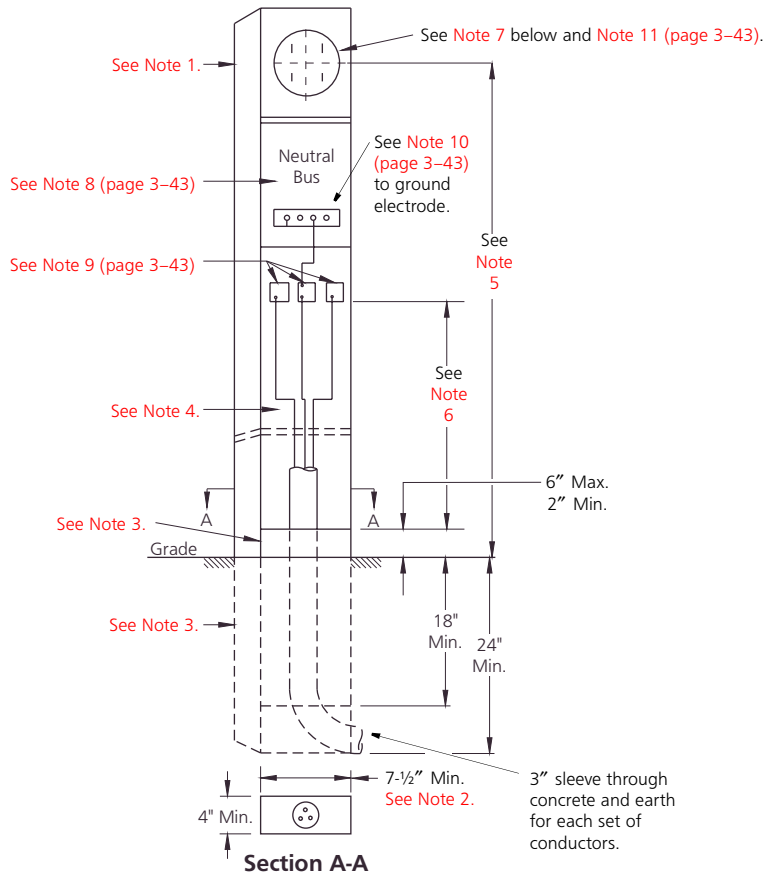

Notes

1. This type post shall have a minimum rating of 100 amperes. Posts shall be installed in such a manner that they will remain plumb and rigid. Construction, material, and corrosive-resistant finish shall be approved by a recognized test laboratory.
2. Minimum width of access opening shall be 7-1/2 inches.
3. The minimum depth of the post in the ground shall be 24 inches, with openings at the base to permit the service lateral conduit or conductors to sweep into the post from the front (meter side). A fixed panel shall extend 2 inches minimum to 6 inches maximum above grade, and 18 inches minimum below grade.
4. Adequate ventilation shall be provided to inhibit the condensation of moisture within the enclosure.
5. The minimum meter height shall be 36 inches above the grade line when the meter is enclosed, or 48 inches when exposed.
6. The service cable pull and terminating section shall be accessible from either the front or rear of the post by removing an 8 inch minimum width sealable panel (or panels). The removable panel (or panels) shall extend from the top of the fixed panel (See Note 3) and when removed, allow full access to the terminating lugs. The service cable pull and terminating section space shall be restricted to Company use.
7. Meter panels shall be removable, but shall be non-removable when meter is in place. If the meter is enclosed, the enclosing cover shall be hinged and self-supporting, equipped with a clear reading window and must be removable for meter testing or inspection.

ESR-3	Underground Service Connections 0-600 Volts	APPROVED <i>PhH</i>
PAGE 3-42	Electrical Service Requirements ▶ SCE Public ◀	EFFECTIVE DATE 7-30-2004

8. The service main disconnect and power outlet section shall have barriers installed to prevent access to the service cable pull and termination section and to unmetred conductors which connect to the socket.
9. The service terminating lugs shall be twin No. 2 to 350 Kcmil aluminum bodied pressure type. Lug height, measured to the bottom of terminating lug from the top of the fixed panel, shall be 18 inches minimum and 48 inches maximum. The space between terminating lugs, from lugs to sides of post, from lugs to any grounded surface, or from lugs to panel above, shall be 1-1/2 inches minimum. Rigid insulated barriers are required and shall project 1/4 inch minimum beyond any energized parts when this space is reduced. Terminating lugs may be positioned either in line or staggered and access shall be unobstructed when all service conductors are in place.
10. A customer accessible equipment grounding lug shall be provided.
11. The meter socket base shall be fabricated with components tested by a recognized test laboratory and shall be provided with a sealing ring. The meter socket shall be mounted on a support which is attached to the meter panel. Sockets shall be factory-wired with conductors in a separate or barriered raceway from the service terminating lugs to the meter socket. These conductors shall be inaccessible from the main disconnect and power outlet section. The conductor which extends to the meter socket, shall be connected at the service terminating lugs, independently of the connection for the service lateral conductors.
12. An unobstructed work space of 36 inches minimum entirely on the property of the customer shall be maintained in front of metering and terminating sections.
13. The grounding electrode conductor may be run through the terminating enclosure.
14. The service equipment (service and meter post), all wiring and equipment from the meter post to the customer's structure shall be provided by the owner/developer.
15. Consult the local Company office before locating the service equipment. When service equipment is improperly located due to the Company not being contacted prior to the installation, the owner/developer is responsible for all modifications.

APPROVED 	Underground Service Connections 0-600 Volts	ESR-3
EFFECTIVE DATE 7-30-2004	Electrical Service Requirements ▶ SCE Public ◀	PAGE 3-43

Figure 3-24: Typical Underground Layout for Mobile Homes

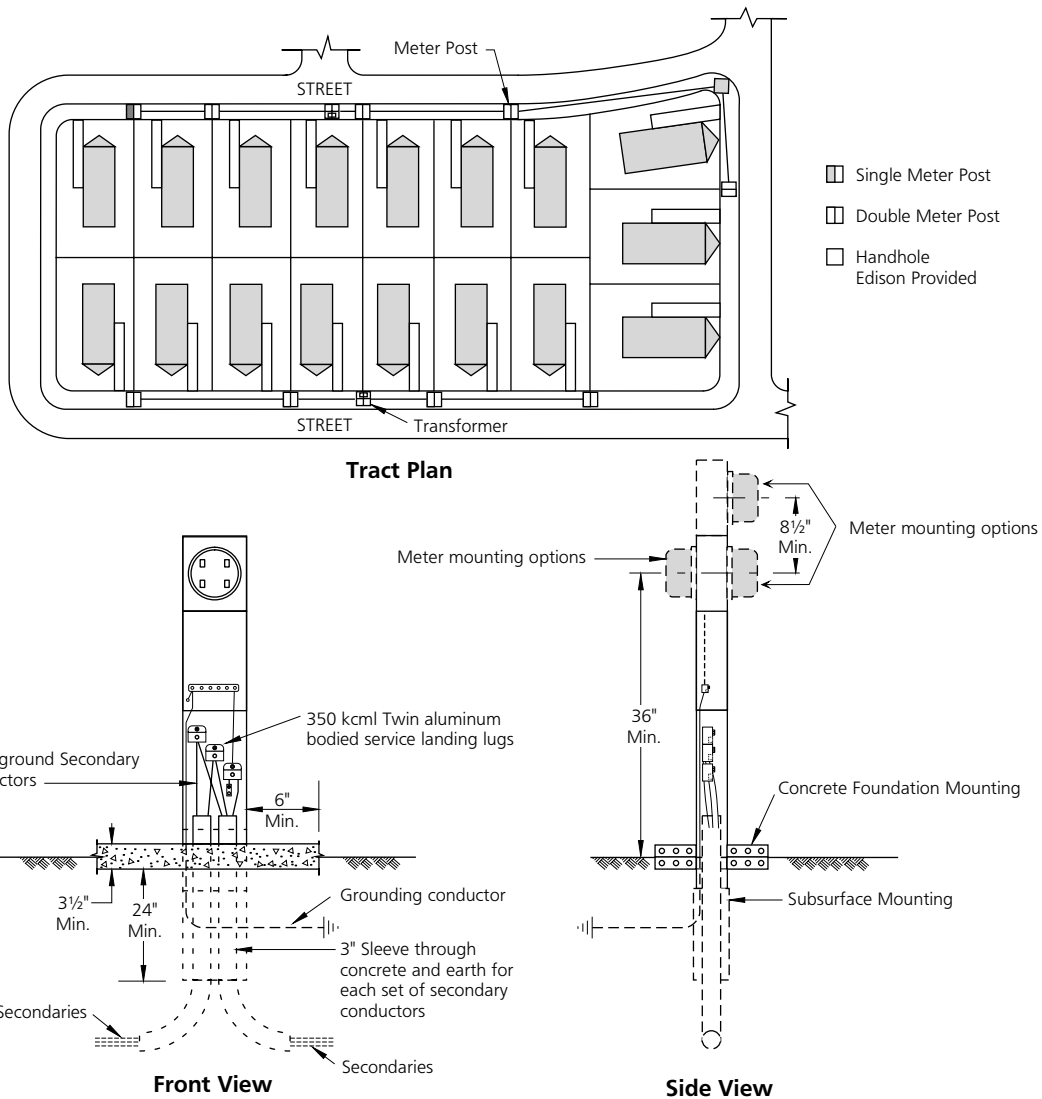

Notes

1. This standard applies to mobile home parks only. Mobile home posts shall be installed in accordance with the provisions in California Administrative Code, Title 25.
2. Mobile Home Parks shall be served from the front street easement. The service equipment (service and meter post) shall be located as shown above. When possible, the double meter type post should be utilized to serve two mobile homes from one location. Dual meter panels are acceptable with meters mounted back to back or in vertical configuration providing the meter post meets all requirements. Meter sockets shall be permanently marked to indicate premises served, see [ESR-5: Section 2.0 "Meter Sockets"](#).
3. Contact the Company local Service Planning Office before locating the service equipment. When service equipment is improperly located due to the Company not being contacted prior to installation, the developer is responsible for all modifications.
4. Refer to [Figure 3-23 \(page 3-42\)](#) for service and meter post requirements.
5. All wiring and equipment from the meter post to the customer's mobile home shall be provided by the developer/owner.
6. The authority having jurisdiction (state/local) may require the park developer to file for special approval when the service and meter post is located in the front street easement.

ESR-3	Underground Service Connections 0-600 Volts	APPROVED <i>PhH</i>
PAGE 3-44	Electrical Service Requirements ▶ SCE Public ◀	EFFECTIVE DATE 7-30-2004

Figure 3-25: Non-Residential Service Pedestals 0-200 Amperes, 0-600 Volts

EUSER DRAWING NO. 308

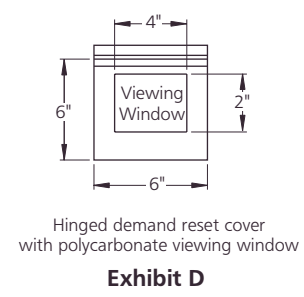
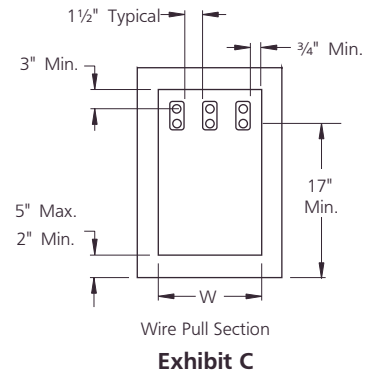
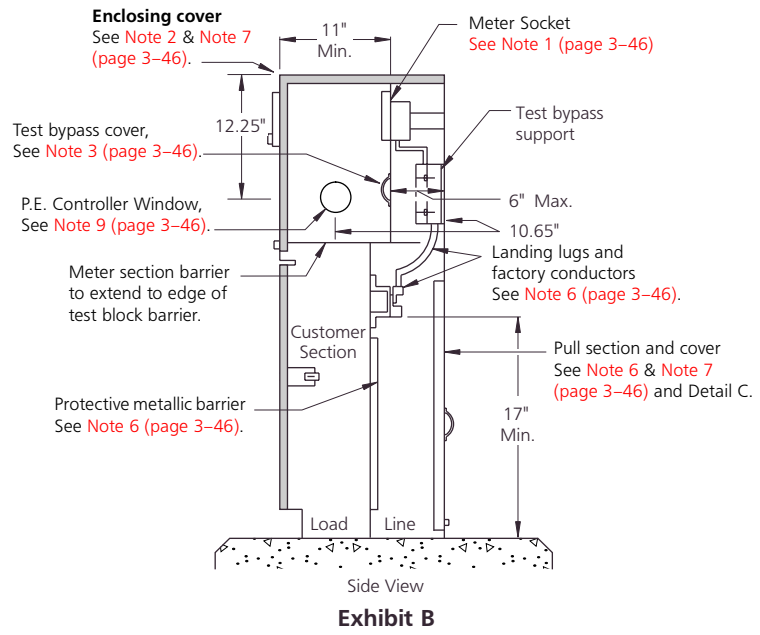
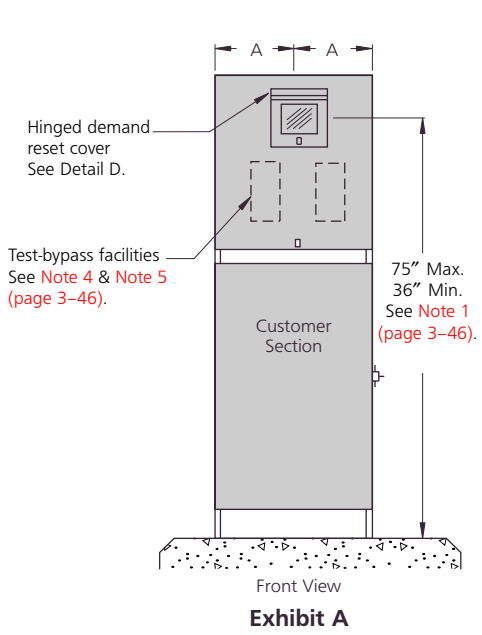

Table 3-7: Terminating Pull Section Minimum Dimensions

Service	W ^(a)	A ^(b)
1 Phase	10-1/2"	10"
3 Phase	12-1/2"	

(a) See Note 6 (page 3-46)
(b) See Note 2 (page 3-46)

APPROVED <i>Ph.H</i>	Underground Service Connections 0-600 Volts	ESR-3
EFFECTIVE DATE 7-30-2004	Electrical Service Requirements ► SCE Public ◀	PAGE 3-45

Notes

1. The meter socket shall be rigidly mounted on a support, attached to the meter panel, and provided with a sealing ring. Ringless sockets are not acceptable. Meter height is measured from the center of the meter-socket.
2. The meter socket shall be enclosed and the enclosing cover shall be:
 - a. Hinged to allow the top and front to be rotated back as one unit to expose the metering compartment. The "A" dimension applies when the metering compartment side panels are fixed and obstruct the meter side clearance. The lifting force required to open the cover shall not exceed 25 pounds.
 - b. Equipped with a lifting handle.
 - c. Provided with a demand reset cover with a viewing window (see Exhibit D). The reset cover shall be sealable and lockable with a padlock having a 5/16-inch lockshaft.
3. Test-bypass compartment covers shall be sealable and fitted with a lifting handle - covers exceeding 16 inches in width shall require two lifting handles.
4. Test-bypass blocks with rigid barriers shall be furnished, installed and wired or bussed to the meter socket by the manufacturer. Connection sequences shall be LINE-LOAD from left to right and clearly identified by 3/4 inch minimum block letter labeling. See **Figure 5-9 (page 5-24)** and **Figure 5-10 (page 5-25)** for test-bypass block details.
5. Test-bypass shall be installed with the following clearances:
 - a. 3-inches of vertical clearance from the upper test connector stud to the upper compartment access opening and 3-inches from the center of the cable terminal screw to the lower compartment access opening.
 - b. 1-1/2 inches of side clearance from the rigid insulating barriers to the compartment sides and 1 inch to the compartment access openings.
6. The terminating pull section shall:
 - a. Comply with the minimum dimensions shown in **Table 3-7 (page 3-45)** (The "W" dimension is measured between the access opening return flanges), accept a minimum 3 inch conduit, and the cover shall be equipped with a lifting handle.
 - b. Be equipped with aluminum bodied, pressure-type lugs, with a range of No. 6 AWG through 250 KCMIL, for termination of the service conductors. Insulated cable or buss shall be installed between the termination lugs and the test-bypass facilities.
 - c. Have a protective metallic barrier (16 gauge minimum) provided between the pull section and the customer distribution section. There shall be a 1/4 inch minimum clearance between the customer section wall and the barrier to prevent screws and bolts from protruding into the pull section.
7. Compartment covers (i.e., meter cover, demand reset cover, and pull section) shall be sealable and lockable with a padlock having a 5/16 inch lockshaft.
8. Internal equipment attached to the outer walls of the enclosure shall be secured in place with devices that may not be loosened from the outside. Screws or bolts requiring special tools for installation or removal are not acceptable.
9. Pedestals serving both metered and unmetered loads, i.e. traffic signals and street lighting, must have landing lugs, with customer wire from lugs to bypasses (metered load) and from lugs to breakers (unmetered loads). A photoelectric (P.E.) receptacle shall be required in the meter/test bypass compartment for the unmetered service. Company will furnish and install P.E. controller for unmetered service.
10. For identification purposes, the numeric portion of the address must be painted with weatherproof paint on the exterior face of the portion of the pedestal facing the street or drivable surface in numbers at least 1 inch high.

ESR-3	Underground Service Connections 0-600 Volts	APPROVED <i>PhH</i>
PAGE 3-46	Electrical Service Requirements ▶ SCE Public ◀	EFFECTIVE DATE 7-30-2004

Figure 3-26: Non-Residential Un-Metered Service Pedestal 0-200 Amperes, 0-240 Volts, Single Phase, LS-2, Street Lighting Systems Only

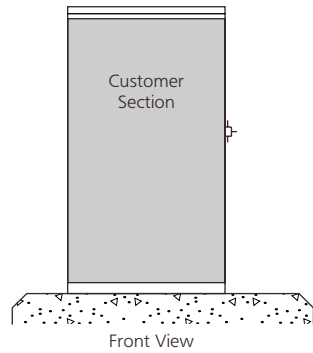

Exhibit A

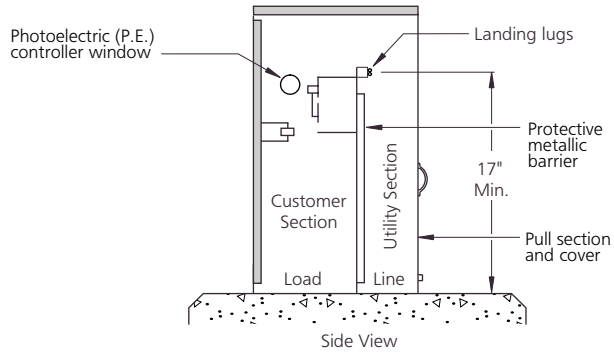

Exhibit B

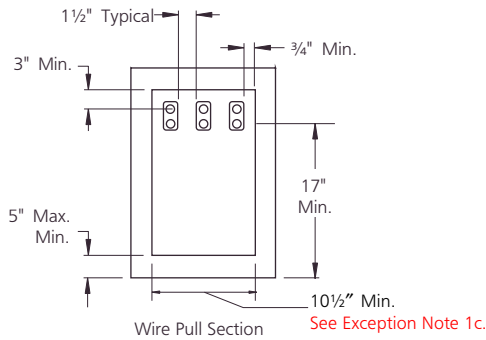

Exhibit C

Notes

1. The Terminating pull section shall:
 - a. Be equipped with aluminum bodied, pressure-type lugs, with a range of No. 6 AWG through 250 KCMIL, for termination of the service conductors.
 - b. Have a protective metallic barrier (16 gauge minimum) provide between the pull section and the customer distribution section. There shall be a 1/4 inch minimum clearance between the customer section wall and the barrier to prevent screws and bolts from protruding into the pull section.
 - c. Comply with the minimum dimensions shown. The width dimension is measured between the access opening return flanges, accept a minimum 3 inch conduit, and the cover shall be equipped with a lifting handle.

Exception:
When the service cable pull and terminating section is accessible from either the rear or side of the pedestal by removing an 8 inch minimum width sealable panel (or panels), the removable panel (or panels) shall extend from the top of the fixed panel and when removed, allows full access to the terminating lugs. Rigid insulated barriers are required and shall project 1/4 inch minimum beyond any energized parts when this space is reduced. Terminating lugs may be positioned either in line or staggered and access shall be unobstructed when all service conductors are in place.
2. Compartment cover of the pull section shall be sealable and lockable with a padlock having 5/16 inch-lockshaft.
3. Internal equipment attached to the outer walls of the enclosure shall be secured in place with devices that may not be loosened from the outside. Screws or bolts requiring special tools for installation or removal are not acceptable.
4. For identification purposes, the numeric portion of the address must be painted with weatherproof paint on the exterior face of the portion of the pedestal facing the street or drivable surface in numbers at least 1 inch high.
5. Service pedestals shall have clear lens (window) for P.E. cells and face north and away from automobile headlights when possible.

APPROVED <i>Ph.H</i>	Underground Service Connections 0-600 Volts	ESR-3
EFFECTIVE DATE 7-30-2004	Electrical Service Requirements ▶ SCE Public ◀	PAGE 3-47

6. If customer's load exceeds the 1,000 watt capacity of the P.E. cell, an auxiliary relay is required.
7. Customer shall furnish and install all of the material:
 - a. P.E. receptacle located in the customer section of the service pedestal.
 - b. Auxiliary relay (when required).
 - c. Disconnect Device.
8. Company will furnish the P.E. cell for un-metered LS-2 pedestals only. When the replacement of the P.E. cell becomes necessary, call (800) 611-1911 to receive a new cell.

ESR-3	Underground Service Connections 0-600 Volts	APPROVED <i>PhH</i>
PAGE 3-48	Electrical Service Requirements ▶ SCE Public ◀	EFFECTIVE DATE 7-30-2004

ESR-4

**COMPANY OWNED
TRANSFORMERS ON
CUSTOMER'S
PREMISES**

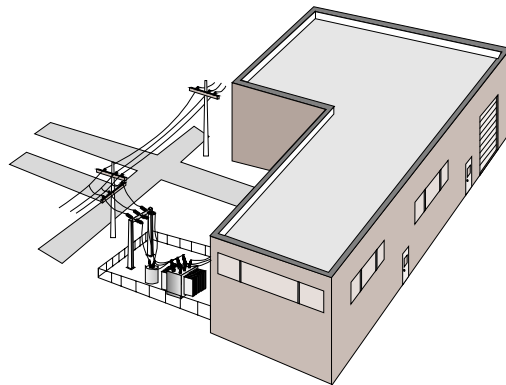

TDBU
► SCE Public ◀



**SOUTHERN CALIFORNIA EDISON
TDBU**

ESR-4: Company Owned Transformers on Customer's Premises

TABLE OF CONTENTS

Section No.	Title	Page
1.0	General Information	4-2
2.0	Transformers on Pole Type Structures	4-2
3.0	Customer Provided Transformer Room or Vault	4-3
4.0	Outdoor Transformer Enclosures	4-4
4.1	Walled Transformer Enclosures	4-4
4.2	Fenced Transformer Enclosures	4-5
4.3	Padmounted Transformers	4-5
4.4	Subsurface Transformers.	4-6
4.5	Service Equipment	4-6
4.6	Service Connections	4-6
4.7	Grounding	4-6

LIST OF TABLES

Table No.	Title	Page
4-1	Approved Methods of Transformer Installation	4-2
4-2	Customer Provided Transformer Room Regulations	4-3
4-3	Fenced Transformer Enclosures	4-5
4-4	Padmounted Transformers—General Locations.	4-6

APPROVED 	Company Owned Transformers on Customer's Premises	ESR-4
EFFECTIVE DATE 1-11-2002	Electrical Service Requirements ▶ SCE Public ◀	PAGE 4-1

1.0 General Information

Company transformers may be installed on a customer's premises when, in the opinion of the Company, such an installation is necessary. The customer shall consult with the local Service Planning office to determine the proposed transformer installation method.

In cases where the Company plans to install transformers on the customer's premises, the customer may be required to furnish, without cost to the Company, an easement providing adequate space for the Company's lines and transformer installation, together with the necessary appurtenances. Easement and space provisions shall be such that required clearances can be maintained between the Company's facilities and adjacent structures, and shall include adequate provision for ingress to and egress from these facilities by Company employees, and shall provide truck access or other approved means for the installation, maintenance and replacement of such facilities. Any vault, room, or enclosure provided by the customer shall comply with all applicable laws of the State of California, and/or municipal regulations of other public bodies having jurisdiction thereof, and shall meet with the approval of the Company.

Where the Company's transformers are to be located on the customers premises, the installation will be made by one of the following methods as shown in **Table 4-1** which shall be approved by the Company with consideration being given to the customer's demand load, suitability for the particular application, and the Company's operating necessity. The capacity of the transformer installation will be determined by the Company.

Table 4-1: Approved Methods of Transformer Installation

Approved Methods	
1.	By a padmounted transformer, on a pad or slab box provided by the customer at their expense.
2.	On an outdoor concrete pad or foundation provided by the customer at their expense, within a fenced enclosure installed on the pad as detailed herein.
3.	In an approved room, vault or outdoor walled enclosure provided by the customer at their expense.
4.	By a subsurface transformer, in a subsurface enclosure provided by the customer at their expense. Consult the Company for methods of service to loads of 6,000 KW demand or more, and loads of a special nature.
5.	For transformer installations of 1,000 KVA or less, on a pole type structure erected by the Company at its expense.

2.0 Transformers on Pole Type Structures

In cases where the Company's transformers are to be installed on a pole type structure(s), the Company will furnish and erect such structures at its own expense. Service from this structure(s) will be supplied in accordance with the Company's rules governing overhead or underground service connections and the following requirements:

For overhead service, the pole type structure(s) shall be located not more than twelve feet from the point of service attachment on the customer's building or structure. This location will be designated by the Company.

The maximum underground service from a pole type structure(s) shall be limited to 2,000 amperes of customer's main disconnect capacity.

ESR-4	Company Owned Transformers on Customer's Premises	APPROVED <i>PhH</i>
PAGE 4-2	Electrical Service Requirements ▶ SCE Public ◀	EFFECTIVE DATE 1-11-2002

Service voltages exceeding 600 volts supplied from a pole type structure(s) to the customer's load terminating facility will normally be installed underground.

3.0 Customer Provided Transformer Room or Vault

A transformer room or vault may be in a building or underground on a customer's premises. Its dimensions, together with provisions for access, ventilation, lighting and drainage, as well as all other details, shall meet with the approval of the Company. No ducts, pipes, conduits, or other foreign infrastructure, except those which are a part of the electrical installation, shall be installed in or through the room or vault except where specifically permitted by the Company. Where installed, it shall be encased in not less than two inches of concrete. Water sprinklers shall not be installed in a transformer room or vault per Titles 8 and 24 of the State of California.

Transformer rooms or vaults shall be in compliance with all applicable laws of the State of California, and/or municipal regulations and/or regulations of other public bodies having jurisdiction thereof, and shall comply with the following Company regulations:

Table 4-2: Customer Provided Transformer Room Regulations

Company Regulations	
1.	Floors shall be of reinforced concrete construction and shall have adequate structural strength to support the load imposed, but in no case less than four inches minimum thickness and a minimum fire resistance rating of three hours. Contact the local inspection authority having jurisdiction for acceptable construction requirements. ^(a)
2.	Walls shall be constructed of six inch reinforced concrete, eight inch filled and reinforced cement block, or eight inch reinforced brick. ^(a)
3.	Doors shall consist of assemblies of materials approved for three-hour noncombustible fire resistive construction. ^(a)
4.	Ceilings – Contact the local inspection authority having jurisdiction for acceptable construction requirements. ^(a)
5.	Vaults provided for residential occupancies, shall be located in or on earth, or shall have a buffer floor between the vault and any occupancy.
6.	Vaults in public health care facilities shall be equipped with seismic anchoring for all Company equipment. The anchoring system shall be designed by the Company and installed by the customer, at customer's expense.
7.	The customer shall provide for adequate natural ventilation or forced ventilation, as required by the Company. In cases where forced ventilation is to be used, the Company will furnish and install the motors, blower, switch and wiring, together with a special transformer where the available voltage is not suitable for direct operation of a blower motor. The customer shall pay to the Company the material cost of the equipment. The Company will, after completion of the original installation, retain ownership of and maintain the equipment at its own expense, and will provide the energy for its operation. With either natural or forced ventilation systems, the customer shall provide all vents and related facilities as part of the vault.

APPROVED 	Company Owned Transformers on Customer's Premises	ESR-4
EFFECTIVE DATE 1-11-2002	Electrical Service Requirements ▶ SCE Public ◀	PAGE 4-3

- (a) Where transformer rooms or vaults are protected by automatic sprinkler systems, i.e.: carbon dioxide or halon systems, construction of a rated one-hour door shall be permitted. Contact the local inspection authority having jurisdiction for acceptable construction requirements. Size of equipment to be installed will dictate minimum door openings. Contact the local service planning office for specific requirements.

Where the customer has provided a room or vault in which Company-owned transformers and switching equipment may be installed, and which meets the requirements of foregoing **Section 3.0 (page 4-3)**, the Company will complete the installation consisting of such protective equipment, primary and secondary bus, and grounding as required.

The customer's service busway shall terminate within the room or vault at a location designated by the Company.

High voltage supply conductors from the Company's lines to a transformer room or vault in which Company-owned transformers are to be installed, will be installed underground. Such supply conductors shall be installed in accordance with the Company's rules governing the supply of underground service.

The customer shall, at their expense, furnish and install all service equipment necessary to receive service at the Company's facilities. The Company will make the connections to its facilities.

The details of design for each service installation shall be approved by the Company prior to the start of construction. Except where approved busway is used, the type, insulation specifications, and terminal fittings of the proposed service entrance conductors for high voltage service shall be approved by the Company prior to their installation.

If any questions arise, contact the local Service Planning office.

When transformer rooms or vaults are improperly engineered and the Company was not contacted in advance, the customer shall be responsible for all modifications and the cost to provide same.

4.0 Outdoor Transformer Enclosures

The customer shall, at their expense, provide and maintain a concrete pad or foundation of such dimensions and specifications as designed by the Company.

Enclosures are required when Company transformers, other than padmounted or subsurface transformers, are installed outdoors.

4.1 Walled Transformer Enclosures

Where the customer desires or the Company requires that the Company's transformers and switching equipment are to be installed in an outdoor walled enclosure surrounding or in conjunction with the concrete pad or foundation specified in the foregoing, and the Company has approved such installation, the customer shall, at their expense, provide the pad or foundation and walled enclosure, together with any protective overhead screen or other appurtenances required by the Company. All dimensions and details of construction of the pad or foundation and the walled enclosure shall meet with the approval of the Company.

The enclosure shall comply with the Electrical Safety Orders of the State of California, and/or with all applicable laws of the state, municipal regulations, or regulations of other public bodies having jurisdiction.

ESR-4	Company Owned Transformers on Customer's Premises	APPROVED <i>PhH</i>
PAGE 4-4	Electrical Service Requirements ▶ SCE Public ◀	EFFECTIVE DATE 1-11-2002

Where the customer has complied with these requirements, the Company will complete the installation consisting of such protective equipment, primary and secondary bus, and equipment supporting structures as it requires.

4.2 Fenced Transformer Enclosures

Normally, fenced transformer enclosures shall be located at least six feet from all buildings, but may be less than six feet from buildings provided: (1) such walls are of blank fire-resistant construction, (2) the customer has installed protective mesh-type fencing as specified by the Company on the roof of the building above and along all walls which are less than six feet horizontally from the transformer enclosure, and (3) all clearances specified in these requirements are maintained.

Table 4-3 identifies the conditions that will apply when a fenced enclosure is installed.

Table 4-3: Fenced Transformer Enclosures

Conditions	
1.	The customer shall, at their expense, furnish and install the fenced enclosure and any required equipment supporting structures in accordance with the detailed specifications of the Company.
2.	The Company will install protective equipment, transformers, primary and secondary conductors per applicable Rules.

High voltage supply conductors from the Company's lines to an outdoor fenced transformer enclosure will normally be installed overhead. Where overhead supply is undesirable, is not practical, or is not in accordance with local ordinances, underground supply conductors shall be installed in accordance with the Company's rules governing the supply of underground service.

Service shall be taken from the enclosure by means of overhead busway, overhead conductors in rigid conduit, or underground conductors in conduit. The supply end of any service raceway shall terminate within the enclosure at a location and in a manner designed by the Company.

The details of design for each service installation shall be approved by the Company prior to the start of construction. Contact the local Service Planning Office for details.

4.3 Padmounted Transformers

Where padmounted transformers are used, installations shall be made in accordance with applicable Company rules and requirements, and state or local codes and ordinances.

Pads or slab boxes for such installations shall be furnished and installed by the customer at their expense. Consult the local Service Planning office for structure specifications and installation requirements.

Pads and slab boxes shall be located as specified by the Company. In general, these structures shall be located as identified in **Table 4-4** (page 4-6).

APPROVED 	Company Owned Transformers on Customer's Premises	ESR-4
EFFECTIVE DATE 1-11-2002	Electrical Service Requirements ▶ SCE Public ◀	PAGE 4-5

Table 4-4: Padmounted Transformers—General Locations

General Requirements for Placement of Pads and Slab Boxes	
1.	Transformers clear the surface of buildings by not less than three feet. This clearance may be reduced to two feet if the building surface is noncombustible.
2.	Horizontal clearance of twelve inches is maintained from the edge of the pad or slab box to projections of the building foundation or other building projections.
3.	Transformers are not placed directly in front of or beneath windows which can be opened, doors, or stairways.
4.	Clearance of at least eight feet can be maintained in front of any padmounted transformer or switch for operating purposes.
5.	Transformers will not be exposed to damage from vehicular traffic. Where exposed to such damage, protective barriers will be required, see ESR-3: Figure 3-3 for barrier details.

4.4 Subsurface Transformers

Where subsurface transformers are used, subsurface enclosures are to be furnished and installed by the customer at their expense. Consult the local Service Planning office for enclosure specifications and all installation details.

4.5 Service Equipment

Service equipment installations shall be made in accordance with the applicable sections of these Electrical Service Requirements. Refer to [ESR-5: Section ESR-5: "Meters — EXO Installations"](#) for EXO installations and [ESR-6: Section ESR-6: "Switchboards 600 Volts and Below"](#) for switchboard designs and installations below 600 volts.

Service equipment locations must have Company approval prior to the installation of any equipment. Where equipment is improperly installed without company approval, any necessary modifications will be at the customers expense. Refer to [ESR-5: Table 5-2 "Prohibited Meter Locations"](#) for prohibited meter locations.

4.6 Service Connections

Where service entrance conductors are installed in conduit by the contractor in compliance with these requirements, the conductors shall extend a minimum of seventy-two inches beyond the end of the conduit.

Where more than three overhead service entrance conductors per phase are necessary, a service entrance busway shall be installed, see [ESR-2: Figure 2-17](#) and [ESR-7: Figure 7-7](#) for busway details. The height of the busway above grade and the busway service head location shall be designed by the Company. Unsupported busway shall extend a maximum of thirty inches inside the vault or enclosure.

The Company will furnish and install the necessary terminal lugs and fittings for its wire or cable. The Company will make the connections to its facilities and to the supply end of the customer's service entrance conductors or busway.

4.7 Grounding

All grounding materials shall be furnished and installed by the customer. Refer to the local service planning office for information on specific details and installations.

ESR-4	Company Owned Transformers on Customer's Premises	APPROVED 
PAGE 4-6	Electrical Service Requirements ▶ SCE Public ◀	EFFECTIVE DATE 1-11-2002

ESR-5

METERS — EXO INSTALLATIONS

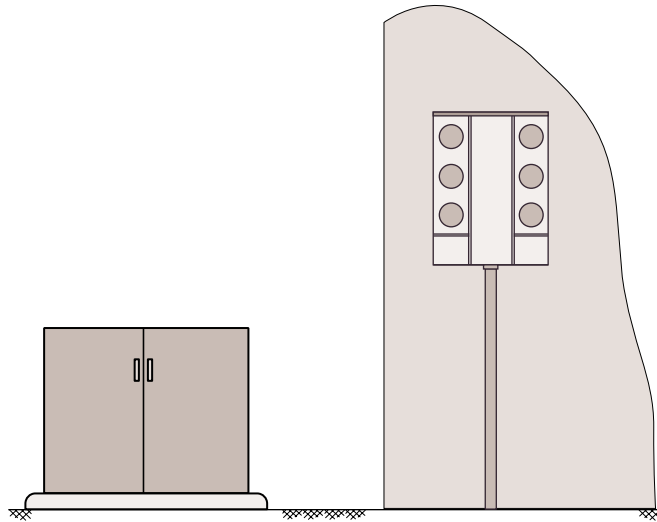

TDBU
▶ **SCE Public** ◀

 **SOUTHERN CALIFORNIA
EDISON**[®]
An *EDISON INTERNATIONAL*[®] Company

“Copyright © 2004 by Southern California Edison Company.”

**SOUTHERN CALIFORNIA EDISON
TDBU**

ESR-5: Meters – EXO Installations

TABLE OF CONTENTS

Section No.	Title	Page
1.0	Single and Three Phase Meters and Metering Equipment	5-4
2.0	Meter Sockets	5-4
3.0	Meter Switch	5-5
3.1	Number of Switches	5-6
3.2	Sequence	5-6
4.0	Main Service Disconnect - Multiple Metering	5-6
5.0	Metering Equipment Installations	5-6
6.0	Meter Locations	5-7
6.1	Meter Access	5-8
7.0	Residential Occupancies	5-11
7.1	Individually Metered 120/240 volt services	5-11
7.2	Individually Metered 120/208 volt three-wire services	5-12
8.0	Commercial and Industrial Occupancies	5-12
8.1	Single Phase Service 120/240 Volt	5-12
8.2	Three Phase Services 120/208 Volt, 240 Volt, 120/240 Volt and 277/480 Volt	5-12
8.3	Meter switch larger than 125 amperes on a 100 ampere safety socket box.	5-13
8.4	Meter Sockets – Self-Contained, Non-Residential	5-13
8.5	Agricultural Power Service	5-14
9.0	Factory Wired Safety Socket Boxes	5-19
9.1	Overhead Service	5-19
9.2	Underground Service	5-19
9.3	Underground Service to Equipment Cabinets or Enclosures	5-20
10.0	Current Transformer Cabinet & Meter Socket Panel	5-27
11.0	Grounding and Bonding	5-33
11.1	Electrical Service Grounding and Bonding Diagrams	5-34

REFERENCE NO. <i>PhH</i>	Meters – EXO Installations	ESR-5
EFFECTIVE DATE 7-30-2004	Electrical Service Requirements ▶ SCE Public ◀	PAGE 5-1

LIST OF TABLES

Table No.	Title	Page
5-1	Meter Location per Type of Occupancy	5-8
5-2	Prohibited Meter Locations	5-10
5-3	Self-Contained & Current Transformer Meter Socket Terminal Arrangements	5-15

LIST OF FIGURES

Figure No.	Title	Page
5-1	Typical Plaque/Directory Specifications	5-5
5-2	Meter Socket – Terminal Arrangements.	5-15
5-3	Separation of Meter Assemblies For Electric and Gas Services	5-16
5-4	Workspace	5-17
5-5	Meter Clearances 0–600 Volts	5-17
5-6	Meter Switches and Main Disconnects	5-18
5-7	Safety Socket Box with Factory-Installed Test-Bypass Facilities 100 Amp	5-20
5-8	Safety-Socket Box with Factory-Installed Test-Bypass Facilities 200 Amp	5-22
5-9	Test-Bypass/Disconnect Block for Safety Sockets 100 and 200 Amp 0–600 Volts	5-24
5-10	Test-Bypass/Disconnect Block for Safety Sockets 100 and 200 Amperes, 0-600 Volts (Bussed and/or Cable Terminations)	5-25
5-11	Safety Socket Box for Meters Used with Instrument Transformers	5-26
5-12	Combination Current–Transformer Cabinet and Meter Socket Panel for Overhead Service 400 Amperes Maximum	5-28
5-13	Combination Current–Transformer Cabinet and Meter Socket Panel for Underground Service 400 Amperes Maximum.	5-29
5-14	Current–Transformer Mounting Base Three-Phase, Four-Wire Services 0–600 Volts, 400 Ampere Maximum.	5-30
5-15	Current–Transformer Mounting Base Single or Three-Phase, Three-Wire Services 0–600 Volts, 400 Ampere Maximum.	5-31
5-16	Single-Phase and Three-Phase Meters and Metering Equipment EXO Current Transformer Installation Meter Spacing and Clearances	5-32
5-17	Combination Meter and Service Section for Overhead Dwelling Service	5-35
5-18	Meter Remote From Service Section for Overhead Dwelling Service	5-36
5-19	Meter and Service with Current Transformer Enclosure Overhead Supply	5-37
5-20	Single-Meter Commercial Service with a Neutral (Where a Main Disconnecting Means is Required)	5-38

ESR-5	Meters – EXO Installations	REFERENCE NO. <i>PhH</i>
PAGE 5-2	Electrical Service Requirements ▶ SCE Public ◀	EFFECTIVE DATE 7-30-2004

LIST OF FIGURES

Figure No.	Title	Page
5-21	Three-Phase, Three-Wire Delta Service with Added Grounding Connector	5-39
5-22	Commercial Service, Overhead Supply – Six Subdivisions or Less	5-40
5-23	Commercial Service, Overhead Supply More Than – Six Subdivisions of Service	5-41
5-24	Combination Meter and Service For Underground Dwelling Service	5-42
5-25	Combination Meter and Service For Underground Multi-Family Dwelling Service – Six Subdivisions of Service or Less	5-43
5-26	Combination Meter and Service for Underground Multi-Family Dwelling Service – More Than Six Subdivisions	5-44
5-27	Combination Meter and Service for Underground Commercial Service – Six Subdivisions or Less	5-45
5-28	Combination Meter and Service for Underground Commercial Service – More Than Six Subdivisions of Service	5-46
5-29	Switchboard Service Section	5-47
5-30	Underground Service Post.	5-48
5-31	Concrete-Encased Electrode (UFER Ground).	5-49
5-32	Typical Single Phase Customer’s Transformer Bonding and Grounding	5-50
5-33	Typical Three Phase Four Wire Wye, Customer’s Transformer Bonding and Grounding . . .	5-51
5-34	Typical Three Phase Four Wire Delta, Customer’s Transformer Bonding and Grounding . .	5-52
5-35	High-Impedance Grounded Neutral System (NEC Section 250-36)	5-53

REFERENCE NO. 	Meters – EXO Installations	ESR-5
EFFECTIVE DATE 7-30-2004	Electrical Service Requirements ▶ SCE Public ◀	PAGE 5-3

1.0 Single and Three Phase Meters and Metering Equipment

All meter installations shall comply with the Electrical Service Requirements of the Company, along with the rules and regulations of electrical inspection authorities having jurisdiction, and with all applicable governing laws and ordinances.

If any question arises concerning these requirements, contact a local Service Planning office. See [ESR-1: Table 1-1 "Service Planning Office – Phone Numbers & Locations"](#) for the addresses and phone numbers of these offices.

Whenever any electrical service wiring is installed, provisions shall be made for the installation of metering equipment complying with these requirements. Existing service equipment which, in the opinion of the company, is satisfactory and adequate for the application may be reused.

Meters will be installed by the Company when the necessary metering facilities are provided and the installation has been approved for service by the local electrical inspection authorities. Meters will not be installed on any installation which does not meet the requirements of the Company or which is considered hazardous.

Unauthorized persons are prohibited from altering or changing, in any way, a meter or its connections. All enclosures and raceways on the line side (unmetered) or housing metering equipment shall be sealable. Meter seals shall not be broken by anyone except an authorized Company employee.

Service equipment exposed to the weather shall be NEMA - 3R, raintight.

For the purpose of these specific requirements, a customer installing their own wiring will be considered the electrical contractor.

For the purpose of these requirements, when one meter registers the current supplied to more than one single family residential occupancy, it shall be considered a commercial installation.

Refer to [Section 11.0 \(page 5-33\)](#) through (page 5-53) for bonding and grounding requirements.

2.0 Meter Sockets

Every new service installation shall be equipped with an approved meter socket and sealing ring together with its supporting raceway or box where these are required. These items shall be furnished and installed by the electrical contractor.

All meter fittings shall be mounted on a substantial support in a true vertical position.

When meters are in place, meter socket terminals shall be inaccessible and meter mounting panels shall be non-removable.

Where a self-contained "A" base meter is in place, and the meter is relocated on the same building or an increase in load requires the installation of larger service conductors or a larger raceway, a new meter panel or switchboard shall be installed.

Meter sockets equipped with circuit closing devices shall not be installed. Ringless type socket enclosures shall not be installed. Any such equipment installed, shall be replaced at the customer's expense, prior to the Company providing service.

See [Table 5-3](#) and [Figure 5-2 \(page 5-15\)](#) for meter socket terminal arrangements.

All new sockets for self-contained metering applications shall be listed by a recognized testing laboratory, i.e.: UL, CSA, etc. Residential meter panels may have a maximum ampere rating of 125, 225 or 400 amperes. See [ESR-3: Section 15.1 "Type Required For Service 0-600 Volts"](#), [ESR-3: Figure 3-6](#) and [ESR-3: Figure 3-7](#). Factory wired safety socket boxes shall have maxi-

ESR-5	Meters – EXO Installations	REFERENCE NO. <i>PhH</i>
PAGE 5-4	Electrical Service Requirements ▶ SCE Public ◀	EFFECTIVE DATE 7-30-2004

imum continuous duty ratings of 100 or 200 amperes. See ESR-5: Section 9.0 "Factory Wired Safety Socket Boxes", Figure 5-7 (page 5-20) and Figure 5-8 (page 5-22) for factory wired safety socket box requirements.

When a service installation does not serve an entire building, the installation shall be permanently marked by the contractor to indicate the portion of the premises served. See Figure 5-1 (page 5-5).

Refer to ESR-6: Figure 6-12 and ESR-6: Figure 6-15 through ESR-6: Figure 6-17 for details of meter socket panel installations in switchboard service sections.

Figure 5-1: Typical Plaque/Directory Specifications^{1/}

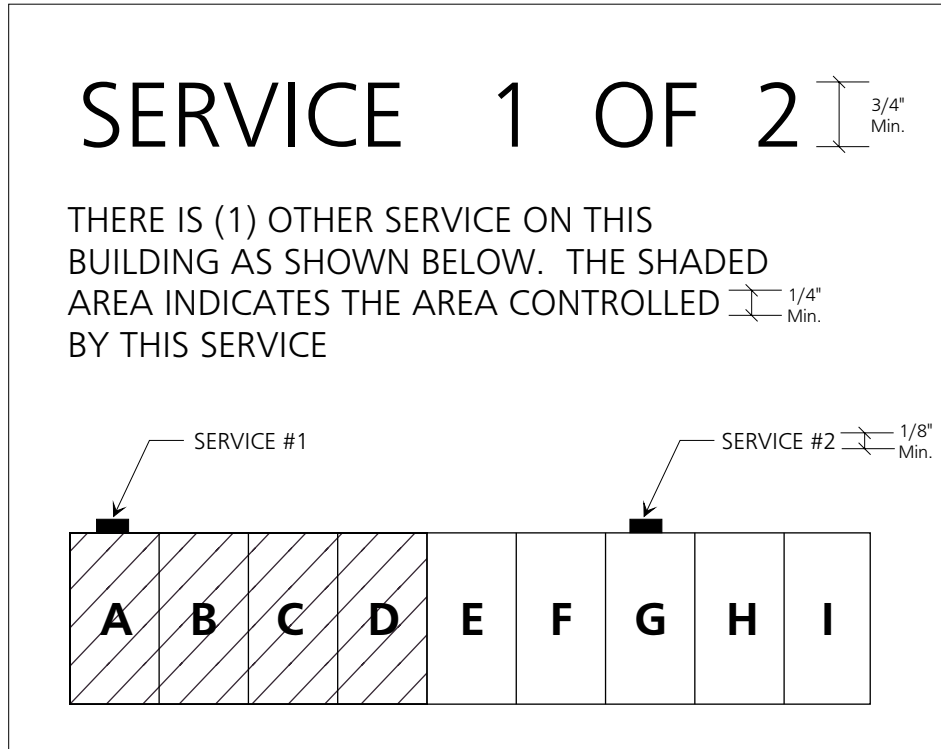

3.0 Meter Switch

For each and every meter, the contractor shall furnish and install a switch, or other approved disconnecting means with overcurrent protection. This is referred to as the "Meter Switch". It shall be installed at the same location and directly adjacent to the metering and service equipment. The meter switch shall control all of, and only, the energy registered by that meter. Where permitted by local code or ordinances, the meter switch may consist of a group of switches or breakers, per NEC 230-71. A separate meter switch will be required for each separate service, of any group where the loads are totalized by a single meter.

1/ The plaque or directory required shall be metal or plastic, with engraved or machine printed letters, or Electro-Photo plating, in contrasting color to the plaque. The plaque shall include a plate map of the entire building, and shall be attached to the service disconnect with pop-rivets, screws, or epoxy.

REFERENCE NO. <i>PhH</i>	Meters – EXO Installations	ESR-5
EFFECTIVE DATE 7-30-2004	Electrical Service Requirements ▶ SCE Public ◀	PAGE 5-5

3.1 Number of Switches

Every meter or service shall be furnished with a meter switch as described in Item 3.0 above. The NEC allows up to a maximum of six switches or disconnects to constitute the main overcurrent device for a single commercial or industrial service. A residential service may have a maximum of two switches or disconnects for each single family service.

3.2 Sequence

Every meter switch installed on an individual service less than 600 volts shall be on the load side of the meter or metering equipment. For service over 600 volts, see **ESR-7: Section 19.0 "Service and Meter Switch"**.

4.0 Main Service Disconnect - Multiple Metering

A main disconnect may be installed on the line side of groups of two to six meter sockets, safety socket boxes, instrument transformer boxes or switchboards where each meter has a single meter switch.

A main disconnect shall be installed on the line side of a group of more than six meter sockets, safety socket boxes, instrument transformer boxes or switchboards.

A main disconnect shall be installed on the line side of groups of two to six meter sockets, safety socket boxes, instrument transformer boxes or switchboards where groups of switches, circuit breakers, or disconnects that constitute the meter switch, and the total number of switches or disconnects exceeds six.^{2/}

The main disconnect may be a fused switch, or a circuit breaker. Where fuses are installed, the Company is not responsible for their replacement. Main disconnect enclosures containing unmetred conductors shall be sealable.

5.0 Metering Equipment Installations

The center line of any meter socket shall not be more than 6 feet 3 inches or less than 4 feet above the standing and working surface. The only exception to the maximum and minimum meter heights is the minimum height of a meter may be reduced to 3 feet when the meter has been enclosed, i.e.: in a meter room, multiple meter closet or commercial meter pedestal. Mobile home service pedestals may be reduced to 3 feet in height above the standing and working surface. Also, where local ordinance dictates a maximum height requirement for equipment located in franchise areas and the minimum meter height of 4 feet cannot be attained, the minimum meter height may be reduced to 3 feet for an exposed meter when a safety socket box with factory-installed test-bypass facilities is mounted and secured to the outside of an enclosure or cabinet (traffic controller, fiber optics or wireless equipment enclosures).

The minimum meter clearance and work space permitted between other meters and sidewalls, ceilings, tops, bottoms and other obstructions shall be as illustrated in **Figure 5-3 (page 5-16)** and **Figure 5-4 (page 5-17)**.

The minimum inside dimension depth of any closet or enclosure for single phase residential meters shall be 7 inches from the face of the meter panel. The minimum inside dimension depth of any enclosure for all other meters shall be 11 inches from the face of the meter panel. The maximum inside dimension depth of recess for all meters shall be 12 inches from the face of the meter panel. See illustrations in **Figure 5-5 (page 5-17)**.

2/ In all installations listed above, the service disconnect shall be installed at the same location and directly adjacent to the meter and service equipment.

ESR-5	Meters — EXO Installations	REFERENCE NO. <i>PhH</i>
PAGE 5-6	Electrical Service Requirements ▶ SCE Public ◀	EFFECTIVE DATE 7-30-2004

A level standing and working surface, entirely on the property served, clear and unobstructed, at least equal to the width and height of the meter space (but not less than 36 inches wide and 6 feet 6 inches high) and extending at least 36 inches from the meter mounting surface. It shall also be provided when meters are enclosed in a cabinet or enclosure. The clear space shall extend at least 36 inches from the outer face of the cabinet or enclosure. See illustrations in [Figure 5-4 \(page 5-17\)](#).

6.0 Meter Locations

All metering facilities shall be located to provide 24-hour access, and preferably on the exterior building wall.

The local Service Planning office shall be contacted to approve the location prior to the installation of meter/service equipment. Any service equipment which has been installed without prior Company approval shall be modified or relocated at the customer/contractors expense.

Where it is determined that all current and future metering facilities are to be installed on an exterior wall, and adequate wall space in an approved location is not available, the builder or architect shall provide a meter closet or illuminated meter room with approved exterior access (**roll up doors are not acceptable**) in which all of the required meter and service facilities may be properly installed. When meters or metering equipment are installed in a lockable enclosure, a lock - box (provided and installed by the Company) shall be permanently secured to the outer surface of the enclosure/door in a permanently accessible location. The customer shall provide a key for the meter enclosure/room door, to the local Service Planning office prior to delivery of service. This key is to be housed in the lock - box for future utility access.

For all single and three-phase self-contained meter installations with individual meter switches rated 200 amperes and below, serving any single or multiple occupancy building (including condominiums in common tenancy and townhouses developed with common areas), the meter and service equipment shall be grouped in one readily accessible central location. When existing meter and service equipment have been established for a building, additional meter and service equipment shall be located with its existing equipment. Consult the service planning office for assistance in determining acceptable meter and service locations.

For townhouse developments where commonly-owned property is not available, individual services may be provided to each townhouse unit.

For any single or multiple occupancy building, when the individual meter switch exceeds 200 amps, consult the local service planning office for acceptable service equipment and meter locations.

No meter or service equipment shall be installed within any individual residential occupancy, in any type of single or multiple occupancy building; within any individual commercial occupancy which it does not serve; or in any location prohibited as identified in [Table 5-2 \(page 5-10\)](#).

[Table 5-1 \(page 5-8\)](#) identifies the type of occupancy for meter installations.

REFERENCE NO. <i>PhH</i>	Meters — EXO Installations	ESR-5
EFFECTIVE DATE 7-30-2004	Electrical Service Requirements ▶ SCE Public ◀	PAGE 5-7

Table 5-1: Meter Location per Type of Occupancy^(a)

Type of Building	
1.	Dwellings or Apartments - Meter and service equipment shall be installed on an exterior wall or exterior meter closet and so located that the meter and service equipment will be accessible without entering the building. Meter locations shall be selected so that future building or other structural changes (i.e., fences, patio enclosures, etc.) will not make the metering facilities inaccessible.
2.	Single Story Buildings - Meter and service equipment may be installed inside a building when located in an illuminated meter room directly accessible from the outside and readily accessible 24 hours a day.
3.	Multi Story Buildings (other than dwellings or apartments) - Meter and service equipment shall be installed as required for single story buildings.

(a) All meter and service related equipment shall be located at one central location which provides 24 hour access or as otherwise agreed to by the Company.

6.1 Meter Access

Access shall be through a door (**roll up doors are not acceptable**) on the building exterior, opening directly into the electric meter room that provides 24 hour access.

Due to different characteristics of a building design, could restrict meter location options. An order of preference shall be used to evaluate and approve meter/metering equipment access. This order of preference is to provide direction for Planners and Design Service Representatives in determining meter/metering equipment location.

- A. Metering facilities and related service equipment are preferred to be located on the exterior of buildings and or structures to provide immediate access.
- B. If exterior locations become unavailable, then customers may install metering facilities inside a meter closet recessed within the exterior structure wall and accessible from the exterior.
- C. The customer may install metering facilities inside a building or structure within an approved meter room. This meter room and location must be approved by the company in advance of construction. The customer shall provide an access door on the building exterior which allows access directly into the meter room. A company provided lock-box will be provided to allow company access directly into the meter room.
- D. If an access door directly into the meter room is not provided, then immediate and non-hazardous access to the meter room shall be required through entrances and areas used during normal business hours. In addition, an exterior door in close proximity to the meter room location shall also be required for installation, replacement, and maintenance of utility service entrance cables and equipment. A local telephone number shall also be readily posted for emergency access during non-business hours to electrical service equipment located within a meter room without direct exterior door access.

In certain cases, the customer may be required by the National Electrical Code (N.E.C.) to provide 2 entrances into a meter room. This is a code issue between the customer and the local authority having jurisdiction.

ESR-5	Meters – EXO Installations	REFERENCE NO. <i>PhH</i>
PAGE 5-8	Electrical Service Requirements ▶ SCE Public ◀	EFFECTIVE DATE 7-30-2004



When meter access problems result due to metering equipment being improperly located and the Company had not approved the location, the customer at their expense will be responsible for all modifications.

If, at any time, the company determines a meter access problem exists, or may exist (i.e., fences, building additions, shrubbery, dogs, hazardous materials, etc.) the customer at their expense shall relocate the metering facilities to a new location acceptable to the Company. For single family dwellings only, an acceptable remote meter reading device may be installed. Installation of this device(s) will be made by the Company. This option is available for 100 and 200 amp residential services only.

REFERENCE NO. <i>PHH</i>	Meters – EXO Installations	ESR-5
EFFECTIVE DATE 7-30-2004	Electrical Service Requirements ▶ SCE Public ◀	PAGE 5-9

Table 5-2: Prohibited Meter Locations^(a) (Sheet 1 of 2)

No metering or service equipment shall be located in any of the following places:	
1.	In any place where moisture, fumes or dust may interfere with their operation or cause damage. The metering equipment may be enclosed to prevent any such result. Contact the local service planning office for specific details.
2.	In any elevator shaft or hatchway.
3.	In any room containing elevator equipment.
4.	In any substation or transformer vault, unless such metering equipment is in an enclosure which is effectively barred from the high voltage compartment and contains no bare or exposed live parts.
5.	Behind any switchboard having bare or exposed live parts unless such meter is located at least five feet from such parts and is effectively barred therefrom.
6.	In any projection room.
7.	In any hazardous location or locations where employees would need to pass through a hazardous area to gain access to metering or service equipment.
8.	Attic or any place not in general use.
9.	Show window or behind a sales counter.
10.	Rest, shower, bath or toilet room.
11.	Directly over any door, window, stairway, ramp, steps or stairs.
12.	Directly over or 18 inches horizontally from a gas meter or plumbing fixture which extends more than 6 inches out from the wall. See illustrations in Figure 5-3 (page 5-16) .
13.	Mechanical or other type of room or structure that contains motors, valves or any piping which is under pressure.
14.	Balcony, mezzanine floor or other elevated location. In any underground vault or other depressed location unless approved by the Company. These locations must be accessible by a stairway of normal tread and rise. A stairway of normal rise (4- to 7-inches) and run (11 inch min.) and conforming to building code requirements is acceptable. Entrance to the location shall be through a vertical doorway not less than 36 inches wide and 78 inches high or through an access way approved by the Company.
15.	On any surface subject to excessive vibration as determined by the Company.
16.	Garage, carport, breezeway, or patio which may be enclosed.
17.	On/Or recessed on any wall in a school building accessible to student traffic. Meters are not permitted in school hallways.

ESR-5	Meters – EXO Installations	REFERENCE NO. <i>PhH</i>
PAGE 5-10	Electrical Service Requirements ▶ SCE Public ◀	EFFECTIVE DATE 7-30-2004

Table 5–2: Prohibited Meter Locations^(a) (Sheet 2 of 2)

No metering or service equipment shall be located in any of the following places:
18. On/Recessed in any wall or structure with less than 3’ of clear level work space in front of the metering equipment or its enclosure(s). This space shall not be impeded by property lines, public thoroughfares, alleys, driveways or walks.
19. Inside any building, unless located within an acceptable meter room which has 24-hour access.
20. In any location not readily accessible 24-hours a day for meter reading, maintenance or replacement of the metering/service facilities.
21. In any area protected by alarm systems, security gates/doors, guard dogs, etc., unless approved by the Company.
22. On mobile homes or trailers ^(b) ; Exceptions: a. Temporary mobile school buildings. b. Residential mobile homes which are: (1) Located on an individual private lot (not mobile home parks) (2) Units are a minimum of 10 feet wide (3) Units installed on a permanent foundation system which is defined by title 25 as: <i>“A foundation system is an assembly of materials constructed below, or partly below grade, not intended to be removed from its installation site, which is designed to support the mobile home and engineered to resist the imposition of external natural forces.”</i> A State HUD form 433 (A) must be submitted to the Company as proof of compliance with these requirements. Only underground service will be provided.
23. Meters shall not be located so as to require reading or servicing from within the fenced portion of a freeway.
24. Meters are not to be placed on Company poles, either jointly or solely owned, except for city agencies with company approval, or in locations where employees would need to pass through hazardous areas to gain access to metering or service equipment.

- (a) The local service planning office shall be contacted prior to the installation of any meter/service equipment. Any service equipment which has been installed without prior Company approval shall be modified or relocated at the customer/contractor’s expense.
- (b) These requirements do not apply to modular/factory built homes. These types of structures will be served the same as any framed (stick built) home.

7.0 Residential Occupancies

Refer to [Table 5–3](#) and [Figure 5–2 \(page 5–15\)](#) for meter socket terminal requirements.

Multi-family occupancies which are not individually metered shall be serviced in accordance with the requirements for commercial and industrial occupancies.

7.1 Individually Metered 120/240 volt services

When a meter switch does not exceed 125 amperes, a 125 maximum ampere rated, four terminal socket shall be installed.

When a meter switch exceeds 125 amperes, but does not exceed 225 amperes, a 225 maximum ampere rated, four terminal socket shall be installed.

REFERENCE NO. <i>PhH</i>	Meters – EXO Installations	ESR–5
EFFECTIVE DATE 7-30-2004	Electrical Service Requirements ▶ SCE Public ◀	PAGE 5–11

When a meter switch exceeds 225 amperes, but does not exceed 400 amperes, a self-contained panel shall be installed, see [ESR-3: Figure 3-7 "Meter Panel for Single-Family Residential Underground Service, 300/400 Ampere \(Class 320\), 120/240 Volt Single Phase 3-Wire"](#). If the meter switch exceeds 400 amperes, a switchboard shall be installed, see [ESR-6: Section 1.0 "Switchboards 600 Volts and Below"](#).

120 volt, two wire services are limited to a maximum load of one 15 ampere and one 20 ampere circuit.

7.2 Individually Metered 120/208 volt three-wire services

For a 120/208 volt three-wire service, when the meter switch does not exceed 125 amperes, a 125 ampere maximum rated, five terminal socket shall be installed.

When a meter switch exceeds 125 amperes, but does not exceed 200 amperes, a 200 ampere continuous duty rated, five terminal socket shall be installed, and a 120/208 volt, three-wire service shall be supplied. Test by-pass blocks will not be required for individually metered residential occupancies.

If the meter switch exceeds 200 amperes, a switchboard for three-phase, four-wire service shall be installed, see [ESR-6: Section 1.0 "Switchboards 600 Volts and Below"](#).

8.0 Commercial and Industrial Occupancies

Safety socket box applications and details can be found in [ESR-5, Section 9.0 "Factory Wired Safety Socket Boxes"](#) (page 5-19) through (page 5-23). Refer to [Table 5-3 \(page 5-15\)](#) and [Figure 5-2 \(page 5-15\)](#) for meter socket terminal requirements.

8.1 Single Phase Service 120/240 Volt

When a meter switch does not exceed 125 amperes, a factory-wired safety socket panel with a 125 maximum ampere continuous duty rated, four terminal socket shall be installed.

When a meter switch exceeds 125 amperes, but does not exceed 200 amperes, a factory-wired safety socket box with a 200 ampere continuous duty rated, four terminal socket shall be installed.

When a meter switch exceeds 200 amperes, a switchboard shall be installed, see [ESR-6: Section 1.0 "Switchboards 600 Volts and Below"](#).

8.2 Three Phase Services 120/208 Volt, 240 Volt, 120/240 Volt and 277/480 Volt

Where a meter switch does not exceed 125 amperes, a factory-wired safety socket box with a 125 maximum ampere continuous duty rated socket shall be installed.

Where a meter switch exceeds 125 amperes, but does not exceed 200 amperes, a factory-wired safety socket box with a 200 ampere continuous duty rated socket shall be installed.

When a meter switch exceeds 200 amperes, a switchboard shall be installed, see [ESR-6: Section 1.0 "Switchboards 600 Volts and Below"](#).

Sockets for 120/208 volt and 277/480 volt three-phase, four-wire services shall be seven terminal, regardless of whether or not the load served utilizes a neutral. Sockets for 120/240 volt three-phase, four-wire services shall be seven terminal. Sockets for 240 volt three-phase power services may be five or seven terminal depending on transformer grounding. Consult the local service planning office for details.

ESR-5	Meters – EXO Installations	REFERENCE NO. <i>PhH</i>
PAGE 5-12	Electrical Service Requirements ▶ SCE Public ◀	EFFECTIVE DATE 7-30-2004

Sockets for 480 volt three-phase, three-wire power services, shall be five terminal. Consult the local service planning office for details.

The local service planning office must be contacted before purchasing or installing, any 240 or 480 volt, three-phase service equipment. They will provide the requirements for each 240 or 480 volt three-phase service installation in question. Where incorrect service equipment is installed and the Company was not contacted in advance, the customer will be responsible for all required modifications.

8.3 Meter switch larger than 125 amperes on a 100 ampere safety socket box.

For motor starting currents only, a meter switch larger than 125 amperes may be installed on a 100 ampere continuous duty rated safety socket box. The maximum wire size or current carrying capacity of conductors installed in the customer's raceway, shall not exceed No. 1 AWG and the conduit size shall not exceed 1-1/2 inches. Whenever the actual continuous operating load current exceeds 100 amperes, a 200 ampere continuous duty rated safety socket box shall be installed.

For motor starting currents only, a meter switch larger than 200 amperes may be installed on a 200 ampere continuous duty rated safety socket box, where the maximum wire size or current-carrying capacity of conductors installed in the customer's service raceway does not exceed 250 kcmil, and the conduit size of such raceway does not exceed 2-1/2 inches. Whenever the actual continuous operating load current exceeds 200 amperes, a switchboard shall be installed, see [ESR-6: Section 1.0 "Switchboards 600 Volts and Below"](#).

8.4 Meter Sockets – Self-Contained, Non-Residential

A safety socket box with factory installed test-bypass blocks, as detailed in [Section 9.0 \(page 5-19\)](#) through (page 5-23), will be required for the following types of installations:

- Commercial and industrial – including all public buildings.
- Multi-family, not separately metered, considered commercial per [Section 7.0 \(page 5-11\)](#).
- All three phase installations (including customer owned permanent and temporary service meter poles.
- Metered street lights, domestic water pumps, or other domestic agricultural installations served by 240/480 volt, three-wire, or 480 volt, two-wire sources.
- Traffic signal enclosures^{3/}.

On underground traffic signal enclosure installations exceeding 120 volts, the customer shall provide the auxiliary relay. The relay shall be placed in the customer's section and shall be located ahead (line side) of the customer's unmetered street light breaker buss.

A safety socket box will be required for a house lighting service in a multi-family residential occupancy. House lighting services include miscellaneous services for laundry rooms, garages, halls, exit lighting, fire alarms, recreation rooms, swimming pools, spas and similar non-commercial uses on the premises.

3/ The test block perch, shall be provided with mounting holes, in the center or right side position for mounting a auxiliary relay, see [Figure 5-11 \(page 5-26\)](#). The Company will only provide and install 120 volt relays.

REFERENCE NO. <i>PhH</i>	Meters – EXO Installations	ESR-5
EFFECTIVE DATE 7-30-2004	Electrical Service Requirements ▶ SCE Public ◀	PAGE 5-13

Exceptions:

1. A safety socket box will not be required for single phase services of a strictly temporary nature rendered on an up and down basis (such as temporary service for construction) when the removal of the entire installation is assured within a short period of time acceptable to the Company.
2. A safety socket box will not be required for single phase service to any single-family, non-commercial installation such as a domestic water pump or other domestic agricultural installation.
3. A safety socket box will not be required for single phase services to any bus shelter installations. Metering on a bus shelter with overhead or underground service will be allowed.
4. A safety socket box will not be required for single phase services that serve an enclosure for the Southern California Gas Company. This enclosure is designed to house cathodic protection equipment (rectifier A.C. to D.C.) for gas company facilities.

8.5 Agricultural Power Service

Three phase 240 volt and 277/480 volt agricultural service will be supplied by the normal method whereby the customer supplies complete service facilities. See commercial and industrial requirements, [Section 8.0 \(page 5-12\)](#).

- A. Where the nameplate horsepower rating of any motor does not exceed 30 HP 240 volts or 60 HP 277/480 volts, a factory bussed safety socket box with a 100 ampere continuous duty rating shall be installed, see [Figure 5-7 \(page 5-20\)](#).

The meter socket for 240 volt service will be five or seven terminal, depending on the grounding of the serving transformer(s). The meter socket for 277/480 volt service will be seven terminal. Consult your local service planning office before purchasing or installing service equipment.

The maximum wire size or current carrying capacity of the conductors installed in the customer's service raceway shall not exceed that of No. 1 AWG wire and the conduit size of such raceway shall not exceed 1-1/2 inches. The capacity of the customers service switch is not limited under these conditions.

The total actual continuous operating load current, excluding motor starting current, shall not exceed 100 amperes.

- B. Where the nameplate horsepower rating of any motor does not exceed 60 hp 240 volts or 125 HP 277/480 volts, a factory bussed safety socket box with a 200 ampere continuous duty rating shall be installed, see [Figure 5-8 \(page 5-22\)](#).

The meter socket for 240 volt service will be five or seven terminal, depending on the grounding of the serving transformer bank. The meter socket for 277/480 volt service will be seven terminal. Consult your local service planning office before purchasing or installing service equipment.

The maximum wire size or current carrying capacity of the conductors installed in the customer's service raceway shall not exceed that of 250 kcmil wire and the conduit size of any such raceway shall not exceed 2-1/2 inches. The capacity of the customers service switch is not limited under these conditions.

The total actual continuous operating load current, excluding motor starting current, shall not exceed 200 amperes.

ESR-5	Meters – EXO Installations	REFERENCE NO. <i>PhH</i>
PAGE 5-14	Electrical Service Requirements ▶ SCE Public ◀	EFFECTIVE DATE 7-30-2004

- C. If the total operating load current, excluding motor operating current, for any reason exceeds 200 amperes, either at the time of installation or thereafter, the customer shall at such time have complete facilities installed at their expense, consisting of an approved switchboard, see **ESR-6: Section 1.0 "Switchboards 600 Volts and Below"**.

Table 5-3: Self-Contained & Current Transformer Meter Socket Terminal Arrangements

Type of Service	Self-Contained Terminals Figure 5-2	Current Transformer Terminals Figure 5-2
Single Phase 120 volt two-wire	4 Clip, Exhibit A	
Single Phase 240 volt three-wire	4 Clip, Exhibit A	5 Clip, Exhibit B or C
Single Phase 120/208 volt three-wire	5 Clip, Exhibit B or C	
Single Phase 240/480 volt three-wire	4 Clip, Exhibit A	
Single Phase 277/480 volt three-wire	5 Clip, Exhibit B or C	
Three Phase 240 volt three-wire ^(a)	5 Clip, Exhibit B or C	15 Clip, Exhibit E
Three Phase 480 volt three-wire ^(b)	5 Clip, Exhibit B or C	15 Clip, Exhibit E
Three Phase 120/208 volt four-wire	7 Clip, Exhibit D	15 Clip, Exhibit E
Three Phase 120/240 volt four-wire Delta ^(c)	7 Clip, Exhibit D	15 Clip, Exhibit E
Three Phase 277/480 volt four-wire	7 Clip, Exhibit D	15 Clip, Exhibit E
Three Phase 2,400-33,000 kV three-wire		15 Clip, Exhibit E
Three Phase 4,160-16,500 kV four-wire		15 Clip, Exhibit E
Totalizing two, three-wire, single phase circuits		15 Clip, Exhibit E
Totalizing three, three-wire, single phase circuits		15 Clip, Exhibit E

- (a) One phase grounded, fourth-wire run for grounding purposes only per G.O. 95 rule 58.2A-1 or G.O. 128 rule 36.5A-1.
 (b) 480 volt three-wire service may be supplied in some areas, consult the local Company office for details.
 (c) Mid-tap grounded, fourth-wire run for a neutral and/or for grounding purposes.

Figure 5-2: Meter Socket – Terminal Arrangements^{4/}

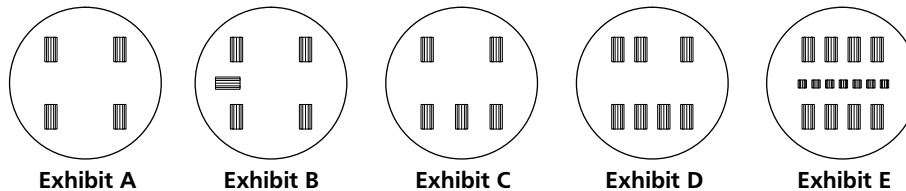

4/ Potential wiring provided for metering shall be a minimum #12 stranded Cu. wire, white in color.

REFERENCE NO. <i>PhH</i>	Meters – EXO Installations	ESR-5
EFFECTIVE DATE 7-30-2004	Electrical Service Requirements ▶ SCE Public ◀	PAGE 5-15

Figure 5-3: Separation of Meter Assemblies For Electric and Gas Services

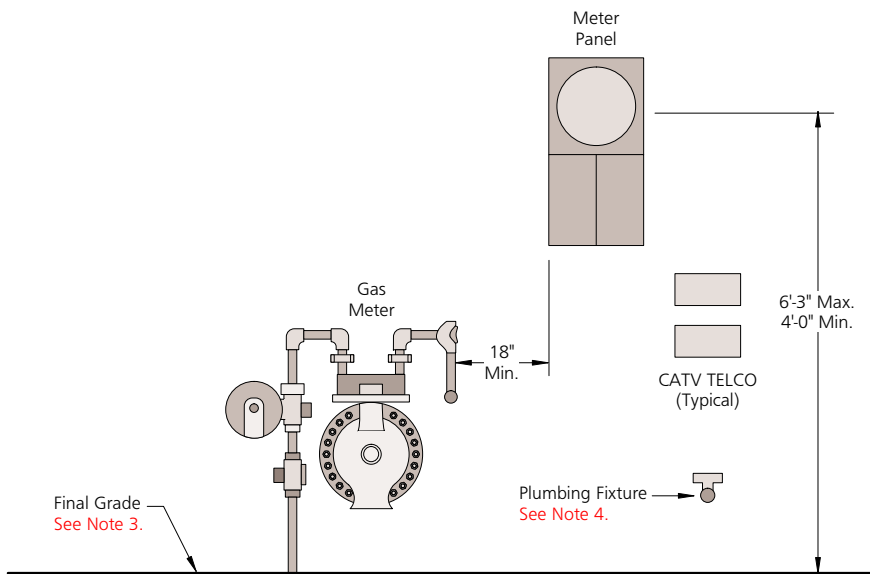
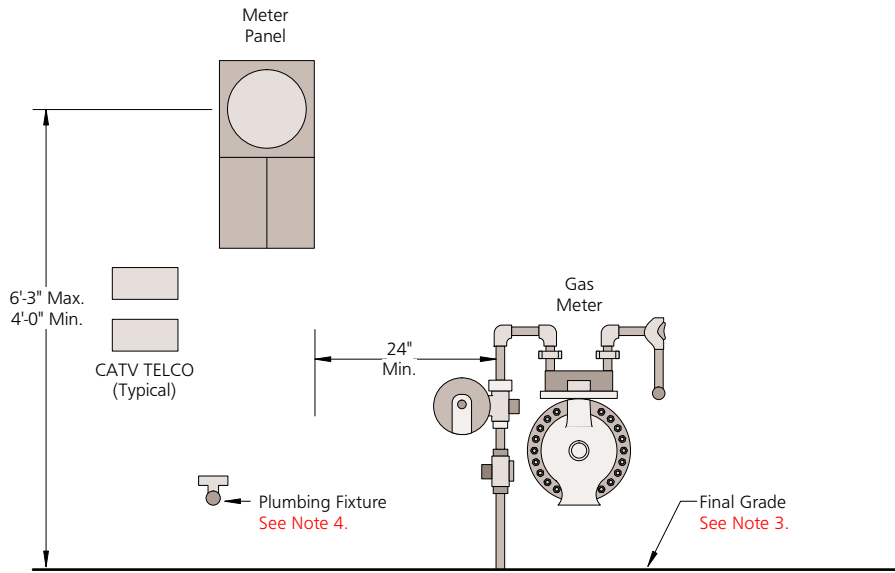

Notes

1. Size and dimensions of panels will vary. Drawings are not to scale.
2. This drawing pertains to both overhead and underground electric service applications.
3. Maintain 3 feet clear, level, and unobstructed work space in front of electric service equipment.
4. Plumbing fixtures which extend more than 6 inches out from wall surface must be located 18 inches minimum from the outside edge of the meter panel.

ESR-5	Meters – EXO Installations	REFERENCE NO. <i>PhH</i>
PAGE 5-16	Electrical Service Requirements ▶ SCE Public ◀	EFFECTIVE DATE 7-30-2004

Figure 5-4: Workspace

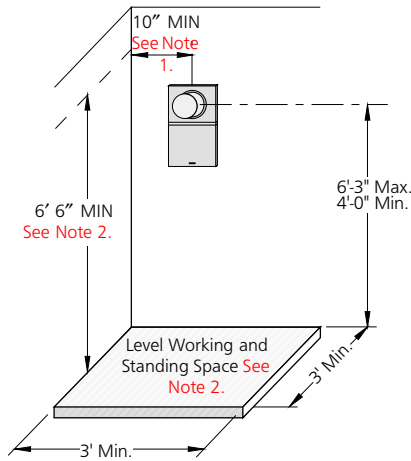

Surface - Mounted or Semi-Flush Meter Installation

Notes

1. The horizontal clearance from the center line of the meter to the nearest side wall or other obstruction shall be 10 inches minimum. A gas meter or plumbing fixture that does not protrude more than 6 inches out from the wall, or extend less than 18 inches horizontally from the outside edge of the meter panel, shall not be considered an obstruction. See [Figure 5-3 \(page 5-16\)](#).
2. A level working and standing surface, clear and unobstructed, entirely on the property of the customer, shall be provided. The minimum width of the workspace shall be 36 inches overall, but need not be centered beneath the meter. The minimum depth of the workspace shall be 36 inches. Where meters are enclosed in a closet or recessed in an enclosure, the depth of the workspace is measured from the outer face of the closet or recess. The minimum height of the workspace shall be 78 inches.

Figure 5-5: Meter Clearances 0-600 Volts

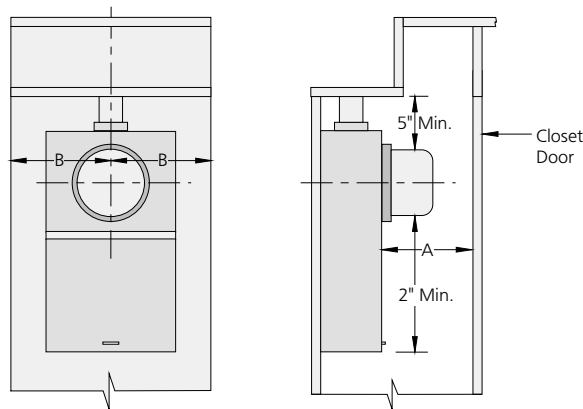

Minimum Enclosed Meter Clearances

	A	B
Residential	7"	10"
Commercial	11"	10"

REFERENCE NO. 	Meters – EXO Installations	ESR-5
EFFECTIVE DATE 7-30-2004	Electrical Service Requirements ▶ SCE Public ◀	PAGE 5-17

Figure 5-6: Meter Switches and Main Disconnects

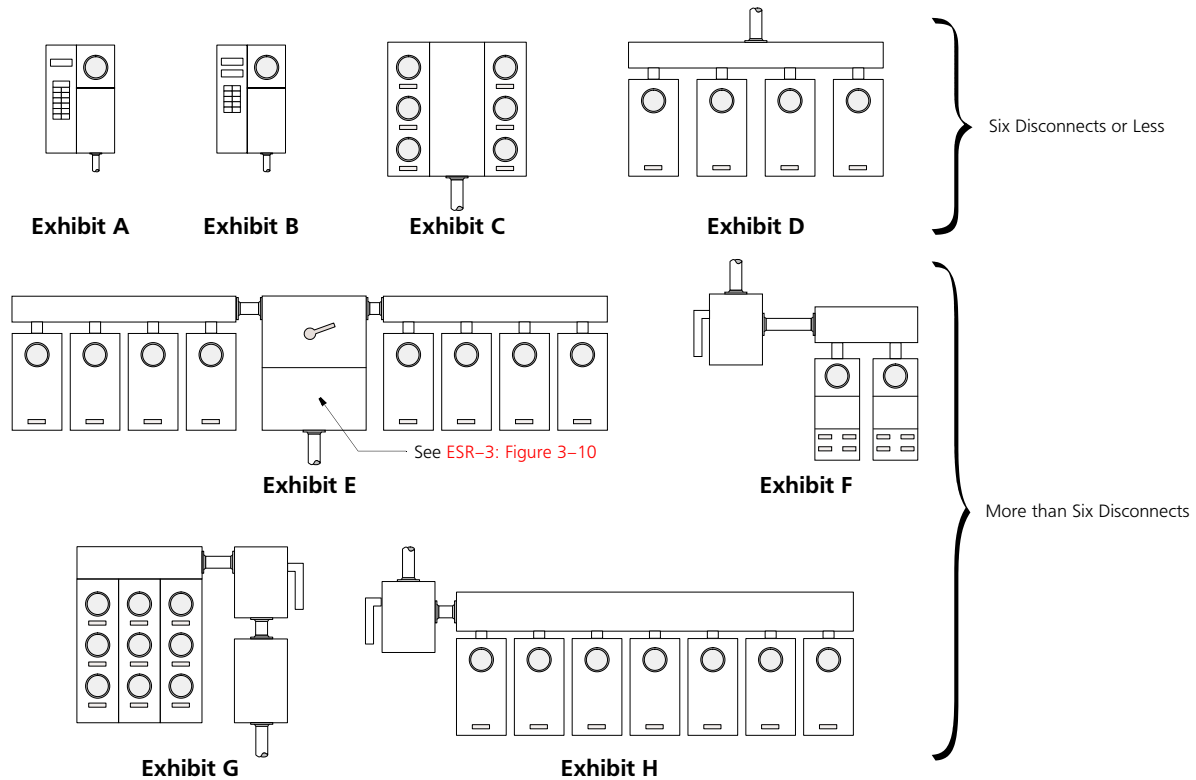

Notes

1. These illustrations are typical of overhead and underground residential and commercial metering configurations, but are not the only acceptable configurations.
2. A meter switch shall be installed for each meter as detailed in [Section 3.0 \(page 5-5\)](#).
3. A main disconnect shall be installed on the source side of a group of more than six disconnects, meter sockets, safety socket boxes, or instrument transformer boxes. See Exhibits E to H in [Figure 5-6](#).
4. A main disconnect may be installed on the source side of a group of two to six meter sockets, safety socket boxes, or instrument transformer boxes where each meter has a single meter switch.
5. A main disconnect shall be installed on the source side of a group of two to six meter sockets, safety socket boxes, or instrument transformer boxes where groups of switches or breakers constitute the meter switches, and the total number of such switches, or breakers, exceeds six. See Exhibits E to H in [Figure 5-6](#).
6. The main disconnect may be a fused switch, or circuit breaker. Where fuses are installed, the Company assumes no responsibility for their replacement. Main disconnect enclosures shall be sealable. See Exhibits E to H in [Figure 5-6](#).
7. Where a main disconnect is placed on the supply side of a group of meters, any equipment tapped ahead of the metering or disconnect shall be separately metered.^{5/}

5/ Exception: NEC required ground fault protection equipment.

ESR-5	Meters – EXO Installations	REFERENCE NO. <i>PhH</i>
PAGE 5-18	Electrical Service Requirements ▶ SCE Public ◀	EFFECTIVE DATE 7-30-2004

9.0 Factory Wired Safety Socket Boxes

All factory wired safety socket boxes shall have factory installed test by-pass blocks which are factory bussed or wired to the meter socket on both line and load sides. Factory wired safety socket boxes shall be listed and labeled with a 100/200 ampere continuous duty rating.

Test by-pass block terminals shall be suitable for copper/aluminum conductors. Factory wired safety socket boxes with 100 ampere continuous duty rated sockets shall be served with a maximum of 1/0 AWG conductors. Factory wired safety socket boxes with 200 ampere continuous duty rated sockets shall be served with a maximum of 250 kcmil conductors. Refer to [Section 8.4 \(page 5-13\)](#), [Figure 5-7 \(page 5-20\)](#) and [Figure 5-8 \(page 5-22\)](#) for specific application requirements.

The wiring sequence of factory installed test by-pass blocks, from left to right, is LINE-LOAD, LINE-LOAD, LINE-LOAD. This wiring sequence shall be permanently labeled in 3/4-inch block letters below the test by-pass terminals. Line and load conductors shall be connected ONLY to test by-pass block terminals designed as LINE and LOAD, respectively.

On 120/240 volt three phase, four-wire installations, and 240 volt three-phase installations where a midpoint grounded fourth wire is run with the service conductors for grounding purposes, the extreme right hand line and load terminals (two poles) shall be labeled POWER LEG.

The contractor shall furnish and install all necessary grounding and bonding on service entrance equipment. Refer to [Section 11.0 \(page 5-33\)](#) through (page 5-53) for details.

Not more than one load circuit shall leave any safety socket box. Load wiring may leave from the bottom, top, top side, bottom side, or bottom rear, but shall not impair access to the test by-pass blocks.

9.1 Overhead Service

The contractor shall furnish and install both line and load wiring from the point of service delivery. The neutral or grounding conductor shall be continuous through the safety socket box and shall be bonded in accordance with [Figure 5-7 \(page 5-20\)](#) and [Figure 5-8 \(page 5-22\)](#).

9.2 Underground Service

A factory wired safety socket box, per [Figure 5-7 \(page 5-20\)](#) and [Figure 5-8 \(page 5-22\)](#), may be used as a combination terminating pull box and a meter socket box where the service conduit enters the center bottom knockout and the test by-pass block terminals are of adequate size for the incoming service lateral conductors. The Company will pull and terminate the service lateral conductors. The contractor shall furnish and install the load wiring.

Where the Company installs service lateral conductors larger than can be accommodated by the terminals of a safety socket box, or where two or more safety socket boxes are ganged together, a separate terminating pull box will be required. The contractor shall furnish the pull box and install the conductors from the terminating pull box to the safety socket box(es). Consult the local Service Planning office for details.

Where a safety socket box is used for unmetered street lighting service, the customer shall provide a means for a photocontroller at the service location. Consult the Company for requirements.

REFERENCE NO. <i>PhH</i>	Meters — EXO Installations	ESR-5
EFFECTIVE DATE 7-30-2004	Electrical Service Requirements ▶ SCE Public ◀	PAGE 5-19

9.3 Underground Service to Equipment Cabinets or Enclosures

Where local ordinance dictates a maximum height requirement for equipment located in franchise areas and the minimum meter height of 4 feet can not be attained, the minimum meter height may be reduced to 3 feet for an exposed meter when a safety socket box with factory-installed test-bypass facilities is mounted and secured to the outside of an enclosure or cabinet (traffic controller, fiber optics or wireless equipment enclosures). The minimum and maximum meter height is measured from the level standing and working surface area to the centerline of the meter socket. See **ESR-3: Section 16.10 "Meter Heights"** for height exceptions.

Figure 5-7: Safety Socket Box with Factory-Installed Test-Bypass Facilities 100 Amp

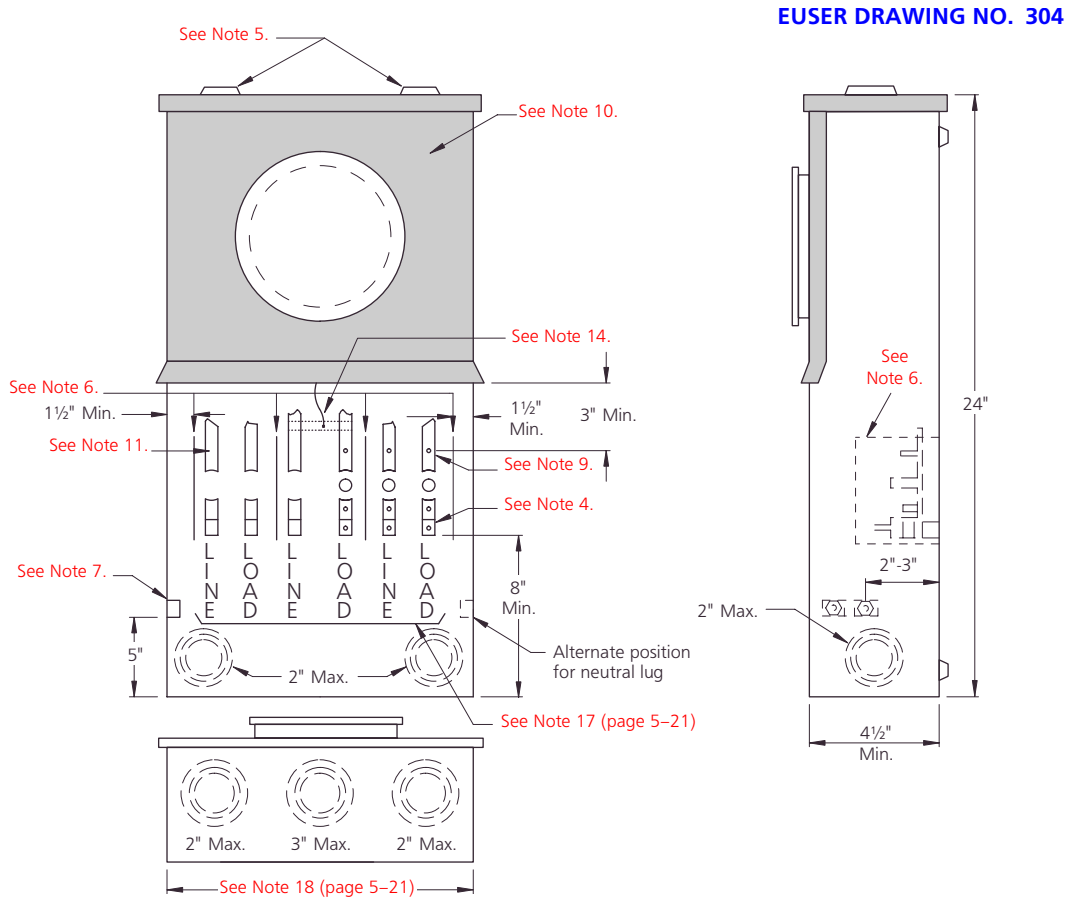

Notes

1. Refer to **Section 8.4 (page 5-13)** for application, **Section 11.0 (page 5-33)** for 240 volt three-phase delta requirements, **Section 9.0 (page 5-19)** for general requirements, and **Figure 5-9 (page 5-24)** for test-bypass requirements.
2. This device may be used for commercial, multi-family residential (not separately metered) agricultural and other types of occupancies.
3. This device may be used as a combination terminating pull and meter socket box for an underground service.
4. Aluminum-bodied terminals for #6 through #1/0 wire capacity.
5. Hubs capped off if used for underground feed.
6. Rigid insulating barriers. See **Figure 5-9 (page 5-24)**.
7. Insulated bondable vertical lay-in, double-neutral lug with #1/0 wire capacity, mounted on either side wall.

ESR-5	Meters – EXO Installations	REFERENCE NO. <i>PhH</i>
PAGE 5-20	Electrical Service Requirements ▶ SCE Public ◀	EFFECTIVE DATE 7-30-2004

8. Test-bypass blocks shall be bussed or wired to socket jaws or terminals. See [Table 5-3](#) and [Figure 5-2 \(page 5-15\)](#) for meter socket clip requirements.
9. Upper test connector studs.
10. All panels shall be independently removable. Meter panel shall be provided with a sealing ring and the meter socket shall be rigidly mounted on a support and attached to the meter panel. Test-bypass compartment cover panel shall be sealable and permanently labeled: "DO NOT BREAK SEALS. NO FUSES INSIDE".
11. Test-bypass block detail on separate drawing, see [Figure 5-9 \(page 5-24\)](#).
12. For three-phase, four-wire, connect seventh jaw to body of neutral lug with #12 strand minimum copper wire, white in color.
13. For three-phase, four-wire delta, identify right-hand test-bypass block (two poles) as power leg. Identification to be orange in color
14. For three-phase, three-wire, install buss to connect line and load poles together at top of center test-bypass block and connect fifth jaw to this buss, using #12 strand minimum copper wire. Color shall be other than white, gray, green or orange.
15. For single-phase, three-wire, provide two test-bypass blocks mounted in outer positions and a four-jaw socket.
16. For single-phase, three-wire 120/208 volts, provide two test-bypass blocks mounted in outer positions and five-jaw socket. Connect fifth jaw of meter socket to body of neutral lug with #12 strand minimum copper wire, white in color.
17. The wiring sequence shall be clearly and permanently labeled in 3/4 inch block letters below the test-bypass terminals.
18. Minimum width of access opening shall be 11-1/2 inches.

REFERENCE NO. <i>PhH</i>	Meters — EXO Installations	ESR-5
EFFECTIVE DATE 7-30-2004	Electrical Service Requirements ▶ SCE Public ◀	PAGE 5-21

Figure 5-8: Safety-Socket Box with Factory-Installed Test-Bypass Facilities 200 Amp

EUSER DRAWING NO. 305

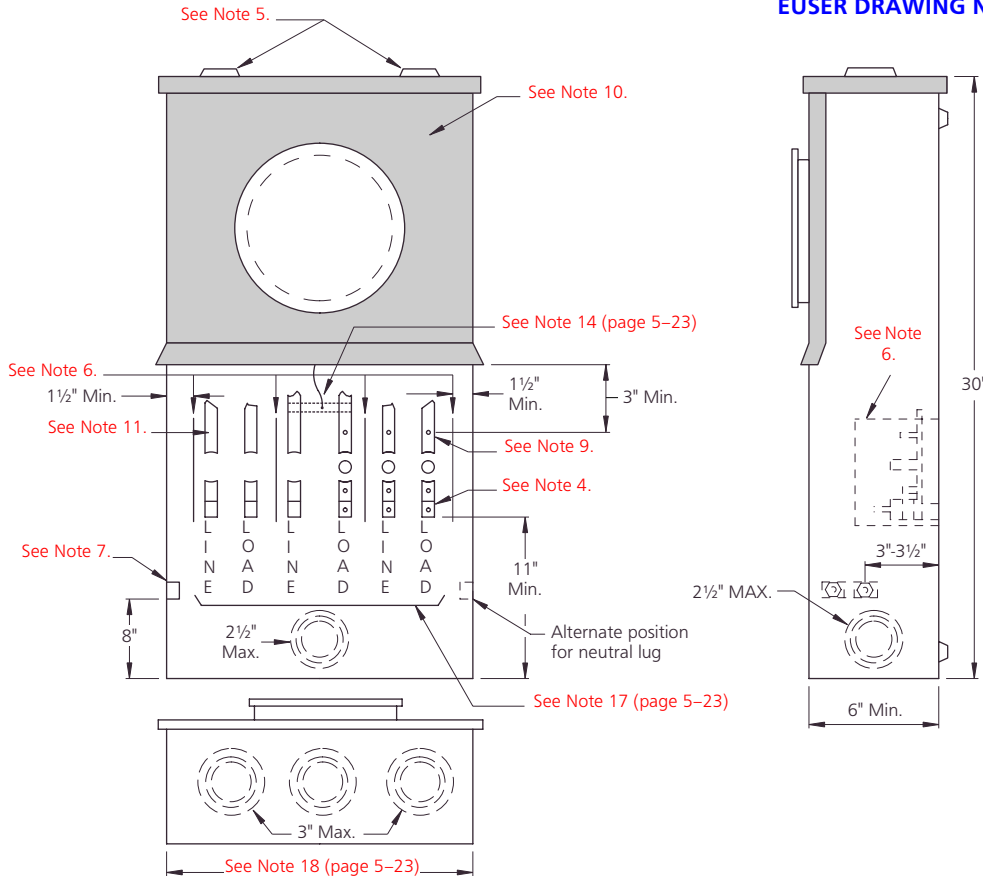

Notes

1. Refer to Section 8.4 (page 5-13) for application, Section 11.0 (page 5-33) for 240 volt three-phase delta requirements, Section 9.0 (page 5-19) for general requirements, and Figure 5-9 (page 5-24) for test-bypass requirements.
2. This device may be used for commercial, multi-family residential (not separately metered) agricultural and other types of occupancies.
3. This device may be used as a combination terminating pull and meter socket box for an underground service.
4. Aluminum-bodied terminals for #1/0 through #250 wire capacity.
5. Hubs capped off if used for underground feed.
6. Rigid insulating barriers. See Figure 5-9 (page 5-24).
7. Insulated bondable vertical lay-in, double-neutral lug with #250 wire capacity, mounted on either side wall.
8. Test-bypass blocks shall be bussed or wired to socket jaws or terminals. See Table 5-3 and Figure 5-2 (page 5-15) for meter socket clip requirements.
9. Upper test connector studs.
10. All panels shall be independently removable. Meter panel shall be provided with a sealing ring and the meter socket shall be rigidly mounted on a support and attached to the meter panel. Test-bypass compartment cover panel shall be sealable and permanently labeled: "DO NOT BREAK SEALS. NO FUSES INSIDE".
11. Test-bypass block detail on separate drawing, see Figure 5-9 (page 5-24).
12. For three-phase, four-wire, connect seventh jaw to body of neutral lug with #12 strand minimum copper wire, white in color.
13. For three-phase, four-wire delta, identify right-hand test-bypass block (two poles) as power leg. Identification to be orange in color.

ESR-5	Meters — EXO Installations	REFERENCE NO. <i>PhH</i>
PAGE 5-22	Electrical Service Requirements ▶ SCE Public ◀	EFFECTIVE DATE 7-30-2004



14. For three-phase, three-wire, install buss to connect line and load poles together at top of center test-bypass block and connect fifth jaw to this buss, using #12 strand minimum copper wire. Color shall be other than white, gray, green or orange.
15. For single-phase, three-wire, provide two test-bypass blocks mounted in outer positions and a four-jaw socket.
16. For single-phase, three-wire, 120/208 volt, provide two test-bypass blocks mounted in the outer positions and a five jaw socket. Connect the 5th jaw of meter socket to body of neutral lug with a No. 12 minimum copper wire, white in color.
17. This wiring sequence shall be clearly and permanently labeled in 3/4 inch minimum block letters below the test-bypass terminals.
18. Minimum width of access opening shall be 13-1/2 inches.

REFERENCE NO. 	Meters — EXO Installations	ESR-5
EFFECTIVE DATE 7-30-2004	Electrical Service Requirements ▶ SCE Public ◀	PAGE 5-23

Figure 5-9: Test-Bypass/Disconnect Block for Safety Sockets 100 and 200 Amp 0-600 Volts

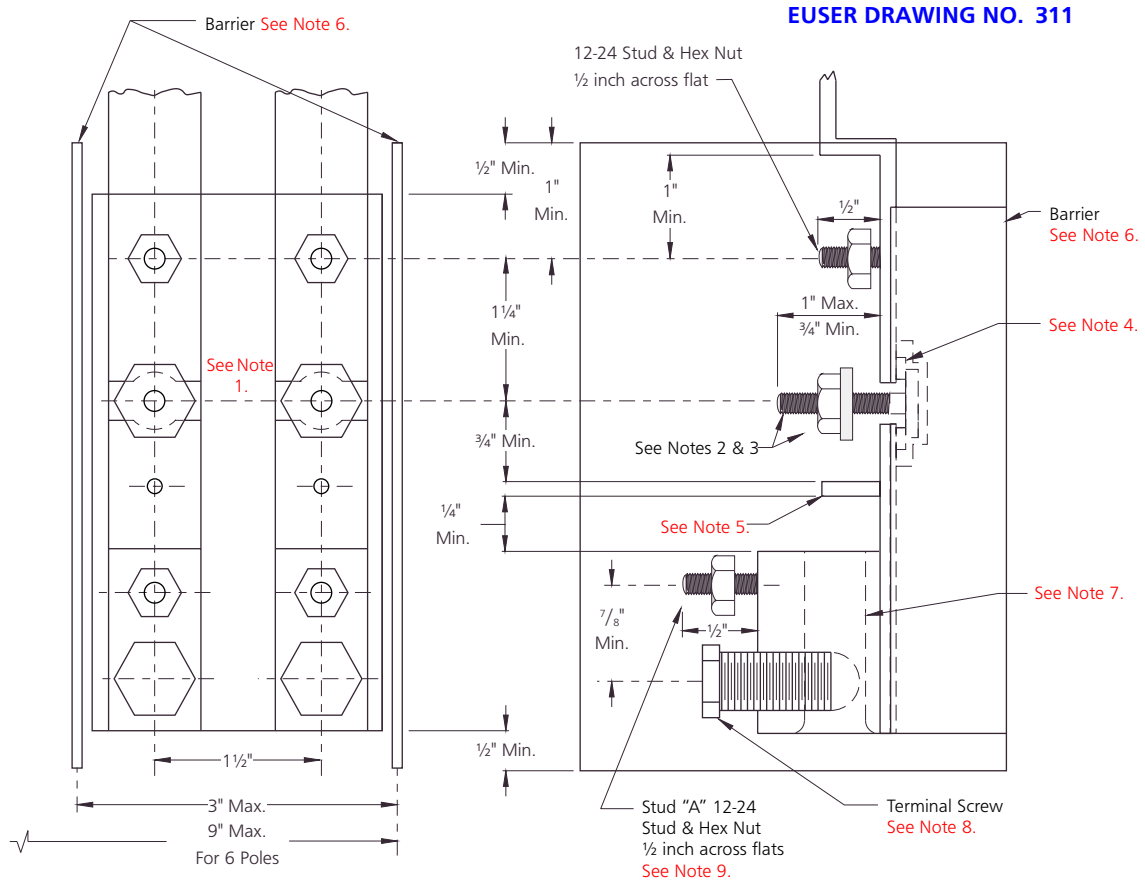

Notes

1. Strike distance between upper and lower buss sections shall not be less than 1/4 inch when shorting nut is backed off.
2. Circuit-closing nut shall be a hex nut 5/8 inch across flats with plated copper washer attached and have threads counter-bored at bottom to facilitate re-installation. Bolt head shall be secured in place to prevent turning and backout.
3. The circuit-closing nut and bolt assembly shall maintain the applied contact pressure between the plated copper washer and the buss members of the test-bypass block.
4. Insulating washer shall be made from dimensionally stable, nontracking material and shall provide a minimum of 1/8 inch creep distance between the bolt and the buss sections. Buss sections shall be plated.
5. Wire stops shall extend to center of terminal opening or beyond.
6. Rigid insulating barriers shall project at least 1/4 inch beyond any energized parts when the maximum wire size is installed.
7. Terminals shall be aluminum bodied. For required conductor range, see Figure 5-7 (page 5-20) and Figure 5-8 (page 5-22). The opening shall extend through the terminal body and, if wire hole is round, shall be chamfered as necessary to facilitate installation of the largest size wire.
8. The terminal screw may be of the allen type (3/16 inch across flats for 100 amp, 5/16 inch across flats for 200 amp). If stud "A" is a part of the terminal screw, the terminal screw shall be 5/8 inch hex across flats.
9. Stud "A" shall be located in the clear area between the terminating lug and the circuit-closing nut, and may be positioned on the terminal body, on the terminal screw, on the buss member, or incorporated as part of the wire stop.

ESR-5	Meters – EXO Installations	REFERENCE NO. <i>PhH</i>
PAGE 5-24	Electrical Service Requirements ▶ SCE Public ◀	EFFECTIVE DATE 7-30-2004

Figure 5-10: Test-Bypass/Disconnect Block for Safety Sockets 100 and 200 Amperes, 0-600 Volts (Bussed and/or Cable Terminations)

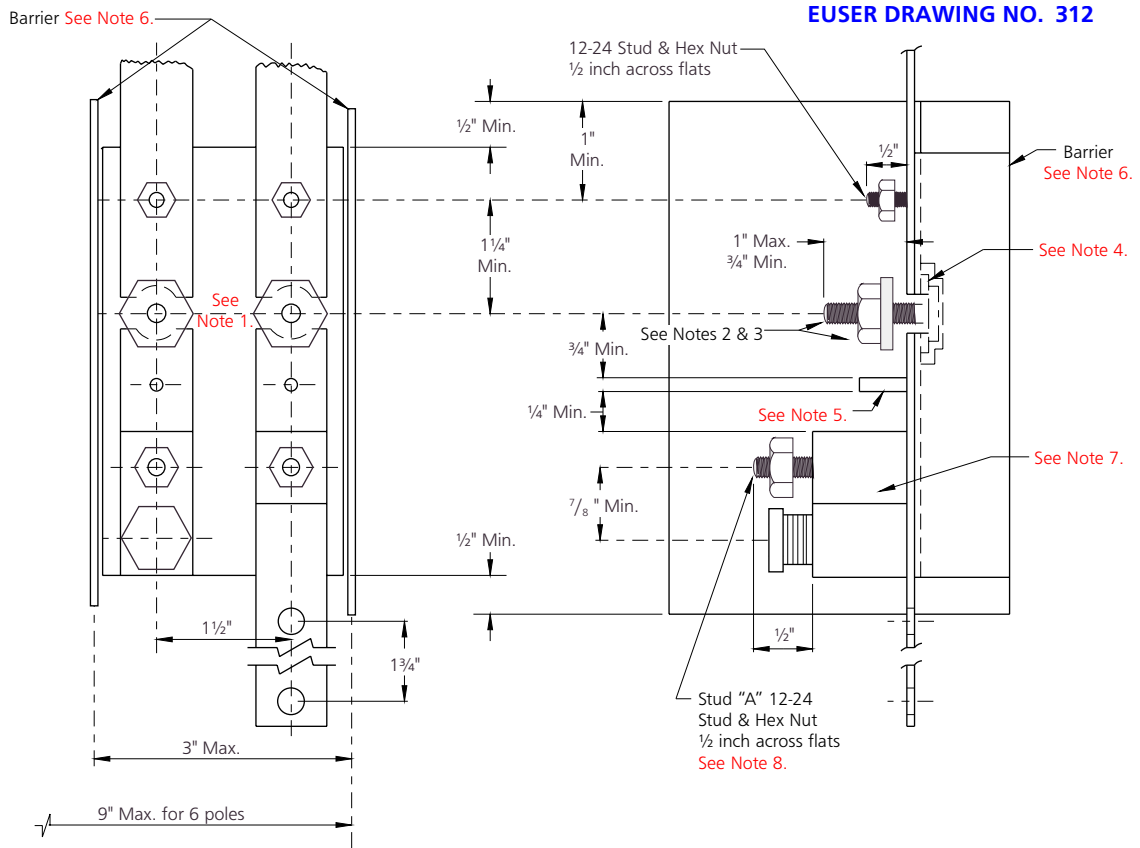

Notes

1. Strike distance between upper and lower buss sections shall not be less than 1/4 inch when shorting nut is backed off.
2. Circuit-closing nut shall be a hex nut 5/8 inch across flats with plated copper washer attached and have threads counter-bored at bottom to facilitate re-installation. Bolt head shall be secured in place to prevent turning and backout.
3. The circuit-closing nut and bolt assembly shall maintain the applied contact pressure between the plated copper washer and the buss members of the test-bypass block.
4. Insulating washer shall be made from dimensionally stable, nontracking material and shall provide a minimum of 1/8 inch creep distance between the bolt and the buss sections. Buss sections shall be plated.
5. Wire stops are not required if line and/or load is connected with buss bar. If cable terminals are used, Figure 5-9 (page 5-24) construction requirements shall apply.
6. Rigid insulating barriers shall project at least 1/4 inch beyond any energized parts when the maximum wire size is installed.
7. Termination of buss bar and cable Line or Load conductors may be cable as per Figure 5-9 (page 5-24) or buss as per this drawing. If buss and cable terminations are used together, proper locations and alignment of stud "A" must be maintained to facilitate the installation of bypass jumpers.
8. Stud "A" shall be located in the clear area between the terminating lug and the circuit-closing nut, and may be positioned on the terminal body, on the terminal screw, on the buss member, or incorporated as part of the wire stop.
9. Serviceability - The line and/or load buss is to be connected to the buss block member in a manner which will allow ready replacement of the test-bypass block assembly.

REFERENCE NO. <i>PhH</i>	Meters — EXO Installations	ESR-5
EFFECTIVE DATE 7-30-2004	Electrical Service Requirements ▶ SCE Public ◀	PAGE 5-25

Figure 5-11: Safety Socket Box for Meters Used with Instrument Transformers

EUSER DRAWING NO. 339

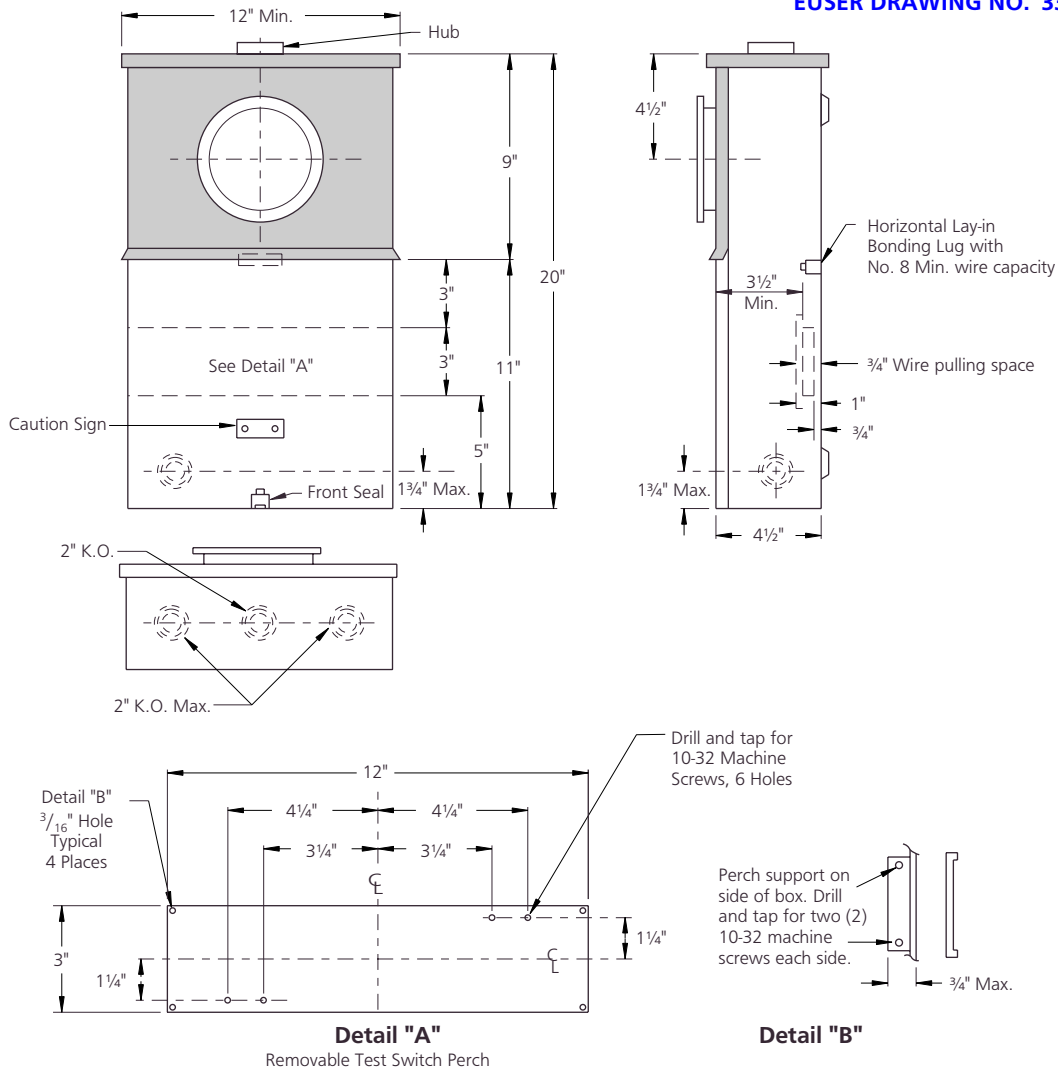

Notes

1. This device may be used as safety socket box where the Company installs a nonresidential 120 volt, two-wire service or a single-phase service requiring auxiliary equipment in the test block compartment. See [Section 8.4 \(page 5-13\)](#).
2. Refer to [Table 5-3](#) and [Figure 5-2 \(page 5-15\)](#) for meter socket requirements.
3. This box is not to be used for commercial, industrial, multi-family, or agricultural self-contained services. See [Figure 5-7 \(page 5-20\)](#) and [Figure 5-8 \(page 5-22\)](#).
4. All section covers shall be independently removable. Upper cover shall be nonremovable when meter is in place. Lower cover shall be sealable and permanently labeled, "DO NOT BREAK SEALS, NO FUSES INSIDE".

ESR-5	Meters – EXO Installations	REFERENCE NO. <i>PhH</i>
PAGE 5-26	Electrical Service Requirements ▶ SCE Public ◀	EFFECTIVE DATE 7-30-2004

10.0 Current Transformer Cabinet & Meter Socket Panel

A current transformer cabinet or switchboard service section shall be installed when the capacity requirements of self-contained metering is exceeded. Use of a switchboard service section is recommended for services 201 to 400 amperes. See [ESR-6: Section 1.0 "Switchboards 600 Volts and Below"](#) for details.

The maximum capacity of a current transformer cabinet installation is 400 amperes. Where the capacity of the largest conductor permitted in the service wiring raceway exceeds 400 amperes, a switchboard service section shall be installed.

A current transformer cabinet may be used as a combination current transformer cabinet and service terminating pull box for separately metered single commercial installations only.

Only conductors associated with metering or grounding shall be permitted in a current transformer cabinet. No connections shall be made in any current transformer cabinet to supply any other meter, except as required by the Company.

RkVah meters associated with current transformer cabinet installations shall be installed in accordance with [Figure 5-11 \(page 5-26\)](#) and [Figure 5-16 \(page 5-32\)](#). Where a current transformer cabinet and its associated safety socket box are located inside a meter room, the entire meter and service installation shall be placed in the same room. No aisle, passage way, door used for through traffic, or other obstruction shall interfere or otherwise restrict ready access between the service equipment. Where located outside of a building, the entire service installation shall be grouped in one location, and the requirements for unobstructed access shall apply.

A level standing and working surface, entirely on the property served, clear and unobstructed, at least equal to the width and height of the current transformer cabinet space and extending not less than 36 inches to the front shall be provided. For all installations, the minimum access and work space shall be 36"×36"×6'-6". Installation of this type of equipment in a cabinet type enclosure is prohibited.

When a meter is installed on an instrument transformer cabinet, the meter panel shall be a minimum No. 12 gauge and a removable secondary test switch perch, drilled and tapped shall be installed as shown in detail in [Figure 5-12 \(page 5-28\)](#) and [Figure 5-13 \(page 5-29\)](#). Where meters are installed adjacent to the instrument transformer box, refer to the requirements in [Figure 5-16 \(page 5-32\)](#).

The contractor shall furnish and install a transformer mounting base as shown in [Figure 5-14 \(page 5-30\)](#) through [Figure 5-15 \(page 5-31\)](#) together with all line and load conductors and pressure type connectors. Where the instrument transformer cabinet is used as a terminating pull box for a single commercial occupancy, the Company will furnish and install the incoming service lateral conductors and their connectors. The Company will furnish and install all instrument transformer secondary wiring.

Conductors attached to the lower mounting base terminals shall incline slightly forward to the front and center of the box to provide a 6 inch minimum clear space along the conductors before bending to enter any knockout. Service conductors shall enter the cabinet at one end, or within two inches of the end, and shall exit the cabinet at the opposite end, or within two inches of that end.

The neutral conductor shall be continuous through the instrument transformer cabinet and shall be run at the rear or along the side of the cabinet. Where used as a terminating pull box, a double neutral lug shall be provided. The neutral shall be bonded to the enclosure.

Refer to [Figure 5-12 \(page 5-28\)](#) through [Figure 5-16 \(page 5-32\)](#) for current transformer cabinet and installation details.

REFERENCE NO. <i>PhH</i>	Meters — EXO Installations	ESR-5
EFFECTIVE DATE 7-30-2004	Electrical Service Requirements ▶ SCE Public ◀	PAGE 5-27

Figure 5-12: Combination Current-Transformer Cabinet and Meter Socket Panel for Overhead Service 400 Amperes Maximum

EUSER DRAWING NO. 313

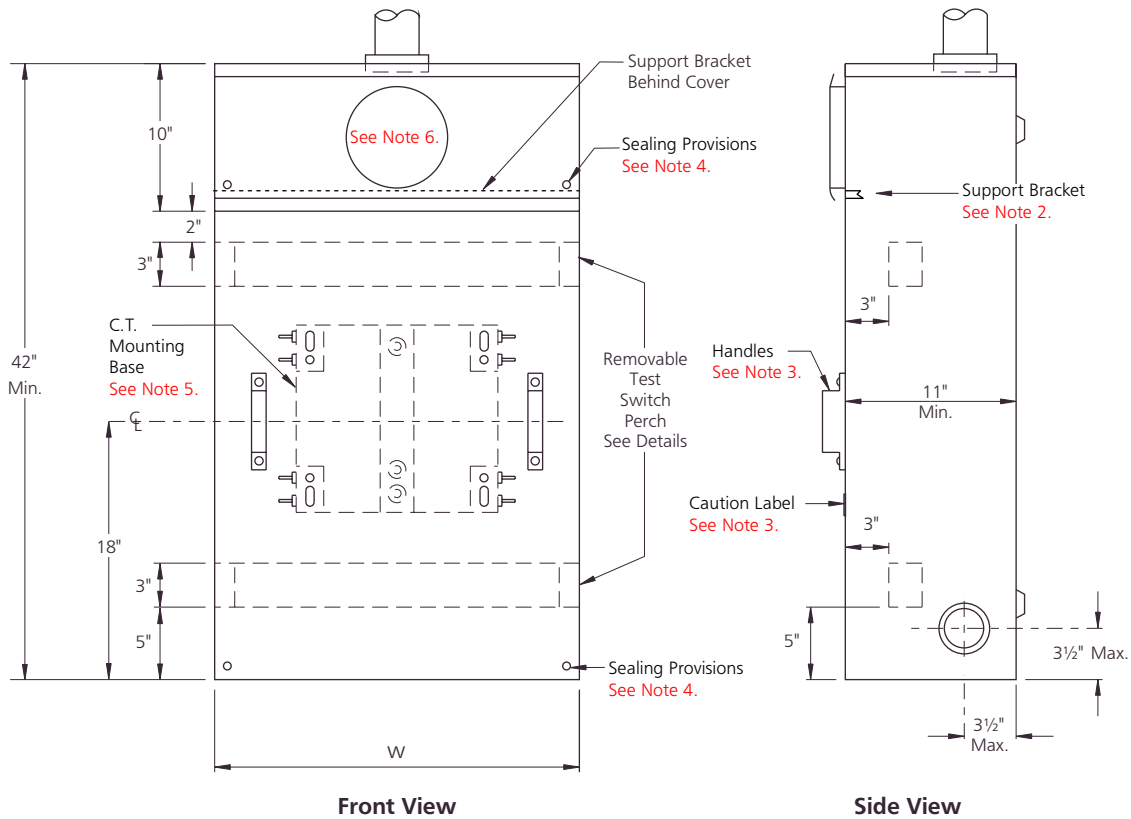

MINIMUM BOX DIMENSIONS	
W (Min.)	
3Ø 4wire Y or Δ	1Ø or 3Ø 3wire
36"	24"

Removable Test Switch Perch

Notes

1. See Section 10.0 (page 5-27) for general requirements.
2. A panel support bracket shall be provided as shown for the meter and current transformer panels. The meter panel shall be attached to the bracket with securing screws to prevent the bracket from pulling out when the meter is removed from the socket.
3. Current-transformer compartment cover panel(s) shall be limited to a maximum of 9 square feet in area, shall have two lifting handles and a caution label reading "DO NOT BREAK SEALS, NO FUSES INSIDE".
4. All meter panel and current transformer compartment cover shall be sealable.
5. See Figure 5-14 (page 5-30) through Figure 5-15 (page 5-31) for C. T. mounting base details.
6. Refer to Table 5-3 and Figure 5-2 (page 5-15) for meter socket requirements.

ESR-5	Meters – EXO Installations	REFERENCE NO. <i>PhH</i>
PAGE 5-28	Electrical Service Requirements ► SCE Public ◀	EFFECTIVE DATE 7-30-2004

Figure 5-13: Combination Current-Transformer Cabinet and Meter Socket Panel for Underground Service 400 Amperes Maximum

EUSER DRAWING NO. 314

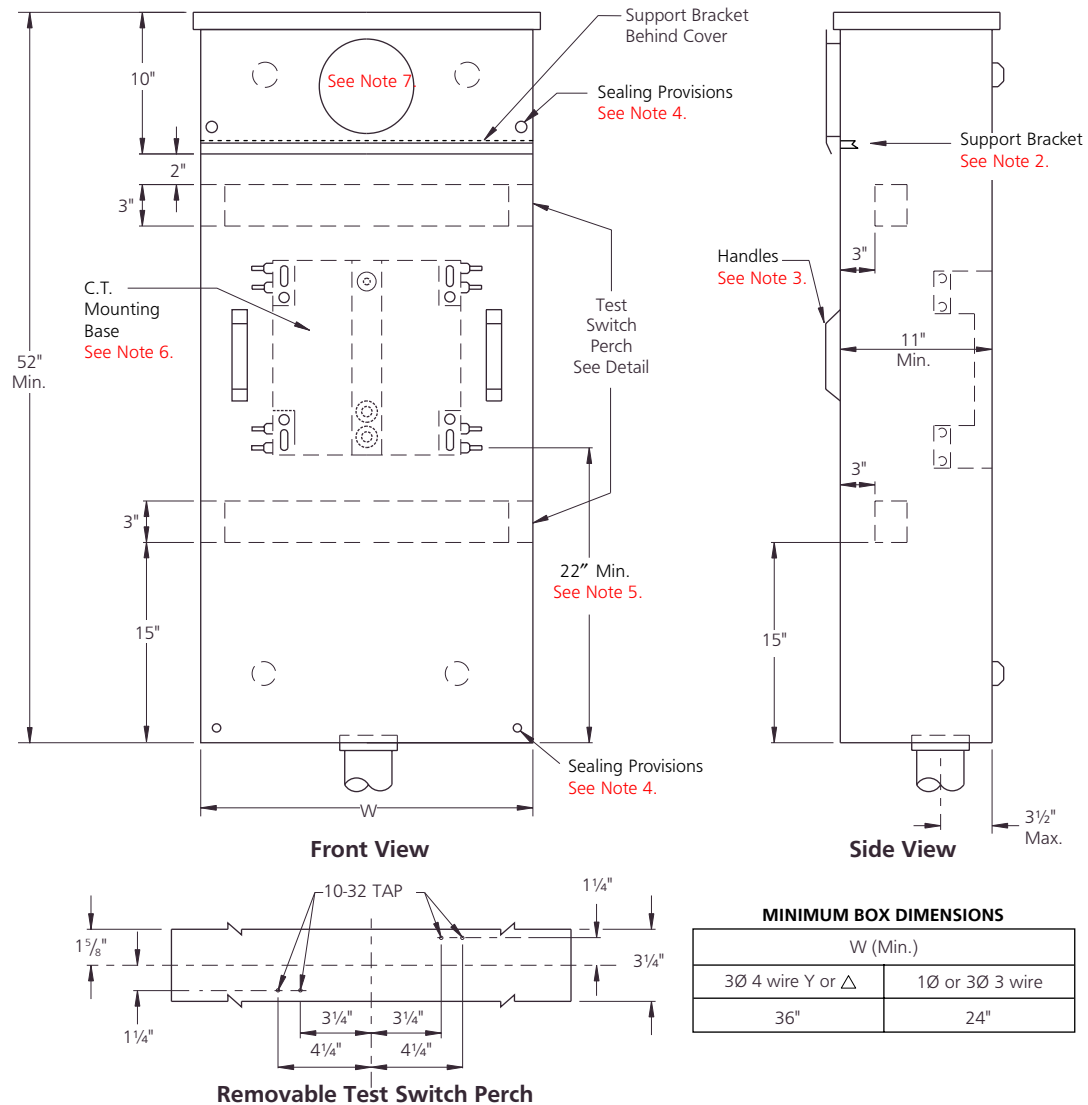

MINIMUM BOX DIMENSIONS	
W (Min.)	
3Ø 4 wire Y or Δ	1Ø or 3Ø 3 wire
36"	24"

Notes

1. See Section 10.0 (page 5-27) for general requirements.
2. A panel support bracket shall be provided as shown for the meter and current transformer panels. The meter panel shall be attached to the bracket with securing screws to prevent the bracket from pulling out when the meter is removed from the socket.
3. The current-transformer compartment cover panel(s) shall be limited to a maximum of 9 square feet in area, shall have two lifting handles and a caution label reading "DO NOT BREAK SEALS, NO FUSES INSIDE".
4. All meter panel and current transformer compartment cover shall be sealable.
5. The termination height dimension is measured from the center line of the lowest termination bolts. The height of the lowest neutral cable termination bolt may be reduced to 20 inch minimum.
6. See Figure 5-14 (page 5-30) through Figure 5-15 (page 5-31) for C.T. mounting details.
7. Refer to Table 5-3 and Figure 5-2 (page 5-15) for meter socket requirements.

REFERENCE NO. <i>PhH</i>	Meters – EXO Installations	ESR-5
EFFECTIVE DATE 7-30-2004	Electrical Service Requirements ► SCE Public ◀	PAGE 5-29

**Figure 5-14: Current-Transformer Mounting Base Three-Phase, Four-Wire Services
0-600 Volts, 400 Ampere Maximum**

EUSER DRAWING NO. 329A

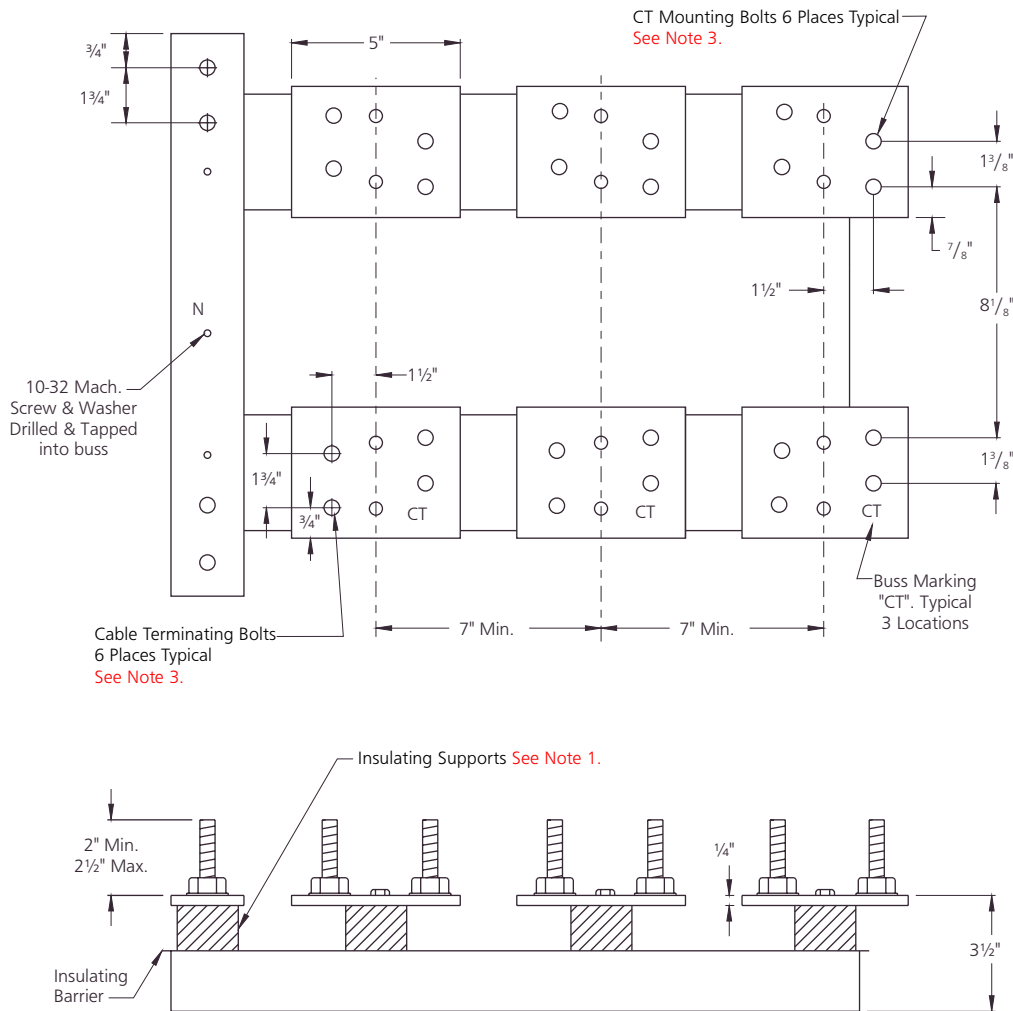

Notes

1. Insulated supports shall be rated for the serving voltage and have sufficient mechanical strength for the application.
2. Mounting base accepts bar type current transformers only.
3. Two 1/2 inch steel bolts shall be provided for each cable terminating position and each bolt shall be furnished with a spring washer and a nut. The spring washer may be either a cone-type (belleville) or a split-ring washer and a flat washer. Bolts shall be secured in place and spaced as shown. All parts shall be plated to prevent corrosion.
4. For applications, see [Figure 5-12 \(page 5-28\)](#) and [Figure 5-13 \(page 5-29\)](#).
5. This mounting base has a maximum AIC rating of 50 kA.

ESR-5	Meters – EXO Installations	REFERENCE NO. <i>PhH</i>
PAGE 5-30	Electrical Service Requirements ▶ SCE Public ◀	EFFECTIVE DATE 7-30-2004

Figure 5-15: Current-Transformer Mounting Base Single or Three-Phase, Three-Wire Services 0-600 Volts, 400 Ampere Maximum

EUSER DRAWING NO. 328A

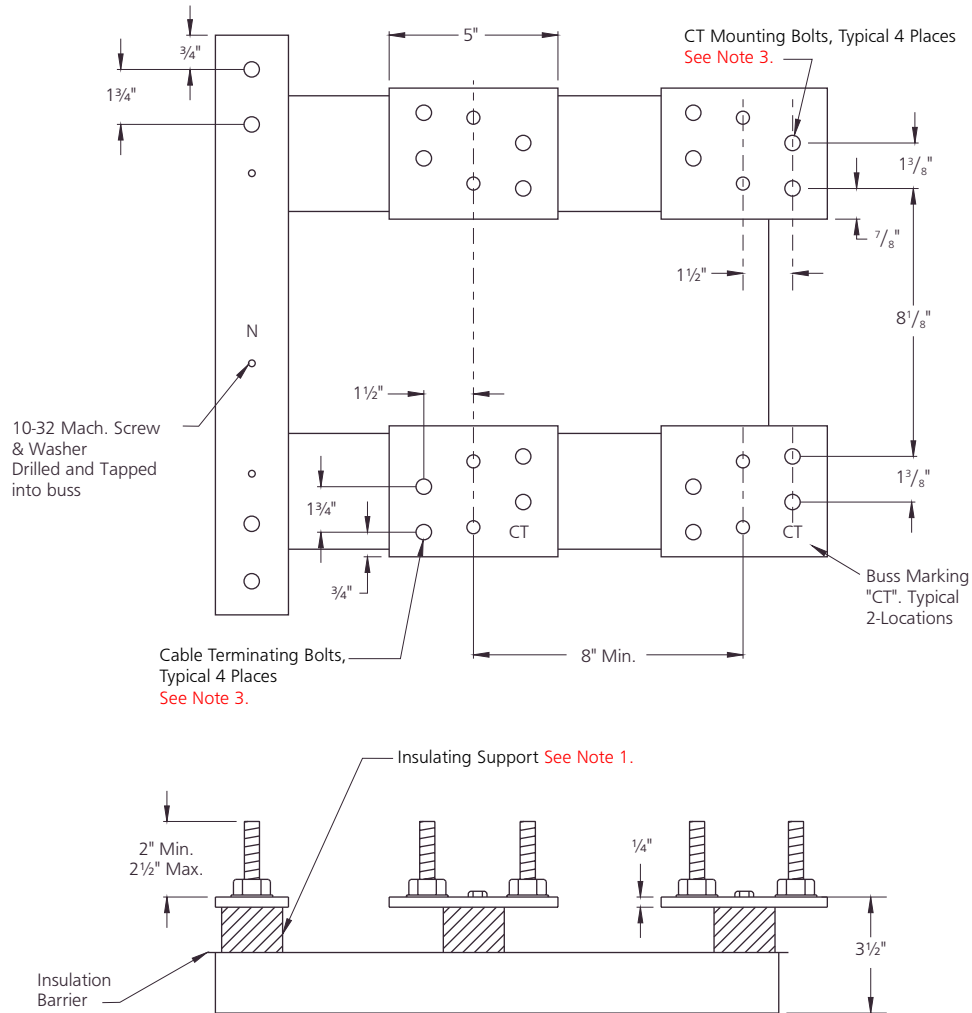

Notes

1. Insulated supports shall be rated for the serving voltage and have sufficient mechanical strength for the application.
2. Mounting base accepts bar type current transformers only.
3. Two 1/2 inch steel bolts shall be provided for each cable terminating position and each bolt shall be furnished with a spring washer and a nut. The spring washer may be either a cone-type (belleville) or a split-ring washer and a flat washer. Bolts shall be secured in place and spaced as shown. All parts shall be plated to prevent corrosion.
4. For applications, see [Figure 5-12 \(page 5-28\)](#) and [Figure 5-13 \(page 5-29\)](#).
5. This mounting base has a maximum AIC rating of 50 kA.

REFERENCE NO. 	Meters – EXO Installations	ESR-5
EFFECTIVE DATE 7-30-2004	Electrical Service Requirements ▶ SCE Public ◀	PAGE 5-31

Figure 5-16: Single-Phase and Three-Phase Meters and Metering Equipment EXO Current Transformer Installation Meter Spacing and Clearances

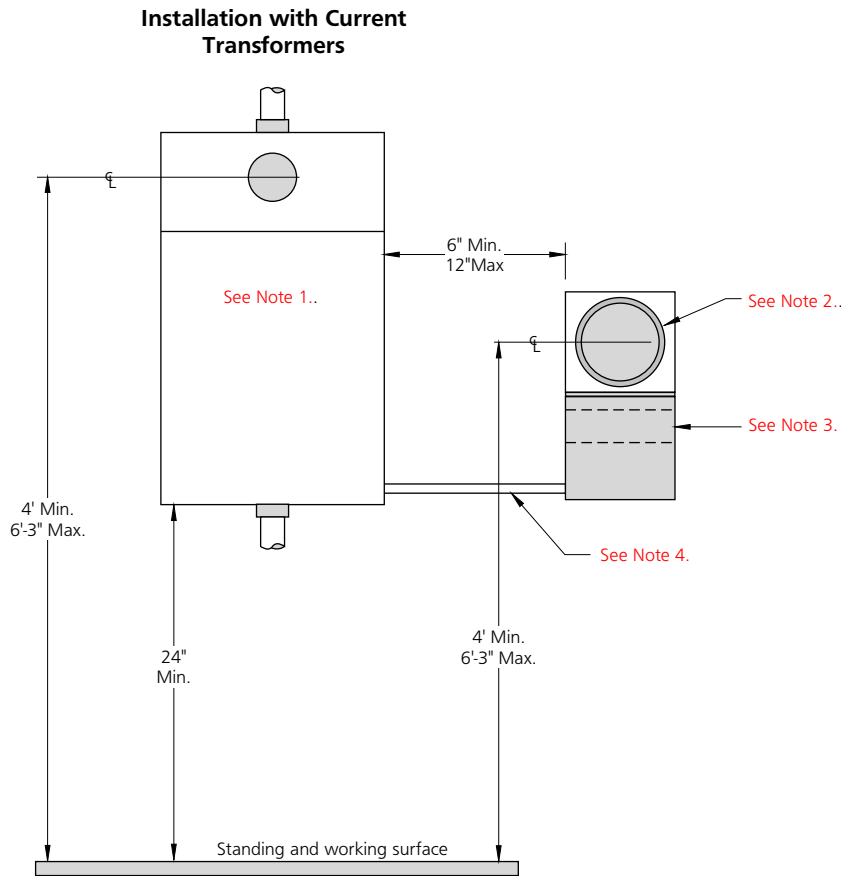

Notes

1. Instrument transformer cabinet, see Figure 5-12 (page 5-28) and Figure 5-13 (page 5-29). See Figure 5-14 (page 5-30) and Figure 5-15 (page 5-31) for current-transformer mounting base.
2. Meter Socket Terminal arrangement see Table 5-3 and Figure 5-2 (page 5-15).
3. Safety socket box, see Figure 5-11 (page 5-26) when a phasing transformer is used.
4. Secondary conduit - minimum 1-1/4 inch. Conduit may leave top, side or bottom of transformer box at any location which does not interfere with the service wiring raceways. See Section 10.0 (page 5-27) for location of boxes.

ESR-5	Meters – EXO Installations	REFERENCE NO. <i>PhH</i>
PAGE 5-32	Electrical Service Requirements ► SCE Public ◀	EFFECTIVE DATE 7-30-2004

11.0 Grounding and Bonding

The California Public Utilities Commission (CPUC) requires transformer windings to be effectively grounded, and where a secondary system is grounded at any point, the Commission and the National Electrical Code (NEC) requires the grounded conductor to be run to each service.

The local Service Planning office must be consulted before purchasing any 240 volt, three-phase service equipment. They will provide specific requirements for each 240 volt installation in question. Where incorrect service equipment is installed and the Company had not been contacted in advance, the customer will be responsible for all modifications.

Two-hundred forty (240) volt, three-phase three- or four-wire delta services will be supplied from secondary systems which have either one phase grounded or the midpoint of one transformer grounded. In either case, the Company will install a neutral or separate grounding conductor with the service conductors, this conductor and the customers neutral or grounding conductor connected to it, shall be bonded as required.

The grounding conductor may pass through the metering compartment, but where a bare wire is used, it shall be barriered from the other service entrance conductors. Typical installations are illustrated in the Electrical Service Grounding and Bonding Diagrams which follow.

The metering requirements for 240 volt, three-phase delta services will vary from location to location depending on the transformer grounding method utilized. Where one phase of the system is grounded, self-contained metering equipment must have five terminal meter sockets and instrument transformer equipment must have fifteen terminal meter sockets. Where the midpoint of one transformer is grounded, self-contained metering equipment must have seven terminal meter sockets and current transformer metering equipment must have fifteen terminal meter sockets, depending on ampacity and buss configuration, see [Table 5-3](#) and [Figure 5-2 \(page 5-15\)](#).

Serving voltages will be supplied as follows:

1. A 120 volt, single-phase, two-wire services will be supplied from secondary systems with one conductor grounded.
2. A 120/240 and 240/480 volt, single-phase, three-wire services will be supplied from secondary systems with the transformer midpoint grounded.
3. A 120/208 and 240/480 volt, single-phase, three-wire services will be supplied from secondary systems with the point common to all transformers grounded. Single-phase services from these systems will be supplied as three-wire services whether or not a neutral is required for the load to be served. Three-phase services from these systems will be supplied as four-wire services whether or not a neutral is required for the load to be served.
4. A 120/240 volt, four-wire delta combination single and three-phase services will be supplied from secondary systems which have the midpoint of one transformer grounded.
5. A 240 volt, three-phase, three or four-wire delta service will be supplied from secondary systems, which have either one phase grounded or the midpoint of one transformer grounded. A 240 volt, 3-phase, 3-wire services and 120/240 volt, 3-phase, 4 wire services shall NOT be served from the same transformer bank.
6. A 480 volt, three-phase, three-wire delta systems are ungrounded.
7. A 277/480 volt, four-wire systems will be wye connected with a neutral supplied with each service whether or not a neutral is required for the load to be served.

REFERENCE NO. <i>PhH</i>	Meters – EXO Installations	ESR-5
EFFECTIVE DATE 7-30-2004	Electrical Service Requirements ▶ SCE Public ◀	PAGE 5-33

With each new service from a grounded secondary system, the Company will install a neutral or grounding conductor. This conductor (or the customer's neutral or grounding conductor connected to it) shall be bonded to the service equipment enclosure under seal and ahead of the meter switch or main service disconnect. The minimum conductor size shall be in accordance with section 250-24 (b) of the current edition of the National Electrical Code (NEC).

All other service wire installation grounding and bonding is subject to the requirements of applicable Codes. Grounding electrode conductors required by such codes shall, where practicable, be connected to the neutral or bonding terminals in compartments which will not be under seal.

11.1 Electrical Service Grounding and Bonding Diagrams

The Southwestern Section of the International Association of the Electrical Inspectors (IAEI) has issued a bulletin under the title Electrical Service Entrance Grounding and Bonding Diagrams. These diagrams are recommended and approved by the Southwestern Section (IAEI). They are, therefore, recognized standards for Arizona, California, Hawaii, Nevada, and New Mexico areas, but are not necessarily the only methods of properly grounding and bonding.

The Company recognizes the value of such standards and has reproduced the diagrams on the following pages. However, with the exception of the bonding requirements detailed previously, these diagrams are not to be considered service requirements of the Company.

ESR-5	Meters – EXO Installations	REFERENCE NO. <i>PhH</i>
PAGE 5-34	Electrical Service Requirements ▶ SCE Public ◀	EFFECTIVE DATE 7-30-2004

Figure 5-17: Combination Meter and Service Section for Overhead Dwelling Service

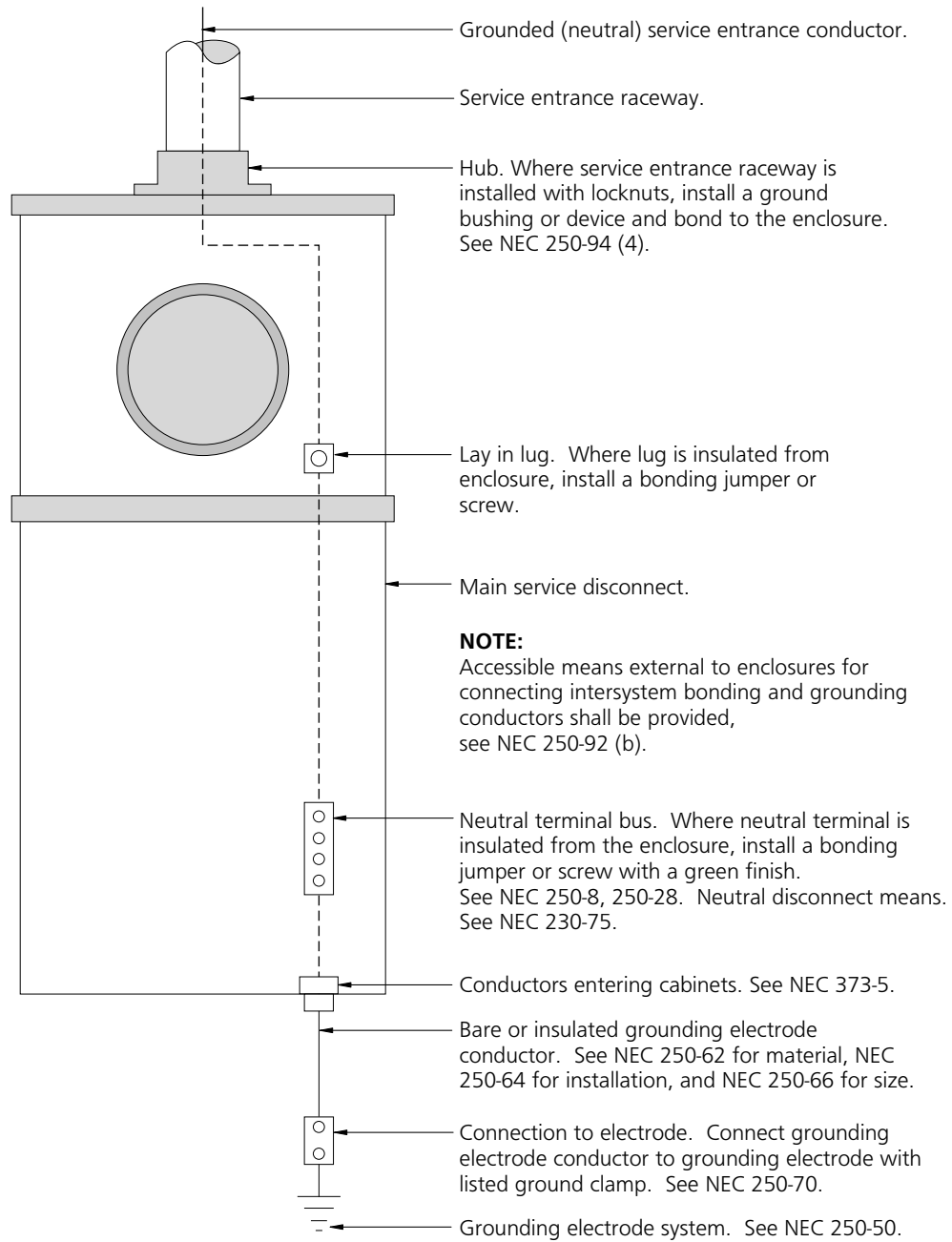

REFERENCE NO. 	Meters – EXO Installations	ESR-5
EFFECTIVE DATE 7-30-2004	Electrical Service Requirements ▶ SCE Public ◀	PAGE 5-35

Figure 5-18: Meter Remote From Service Section for Overhead Dwelling Service

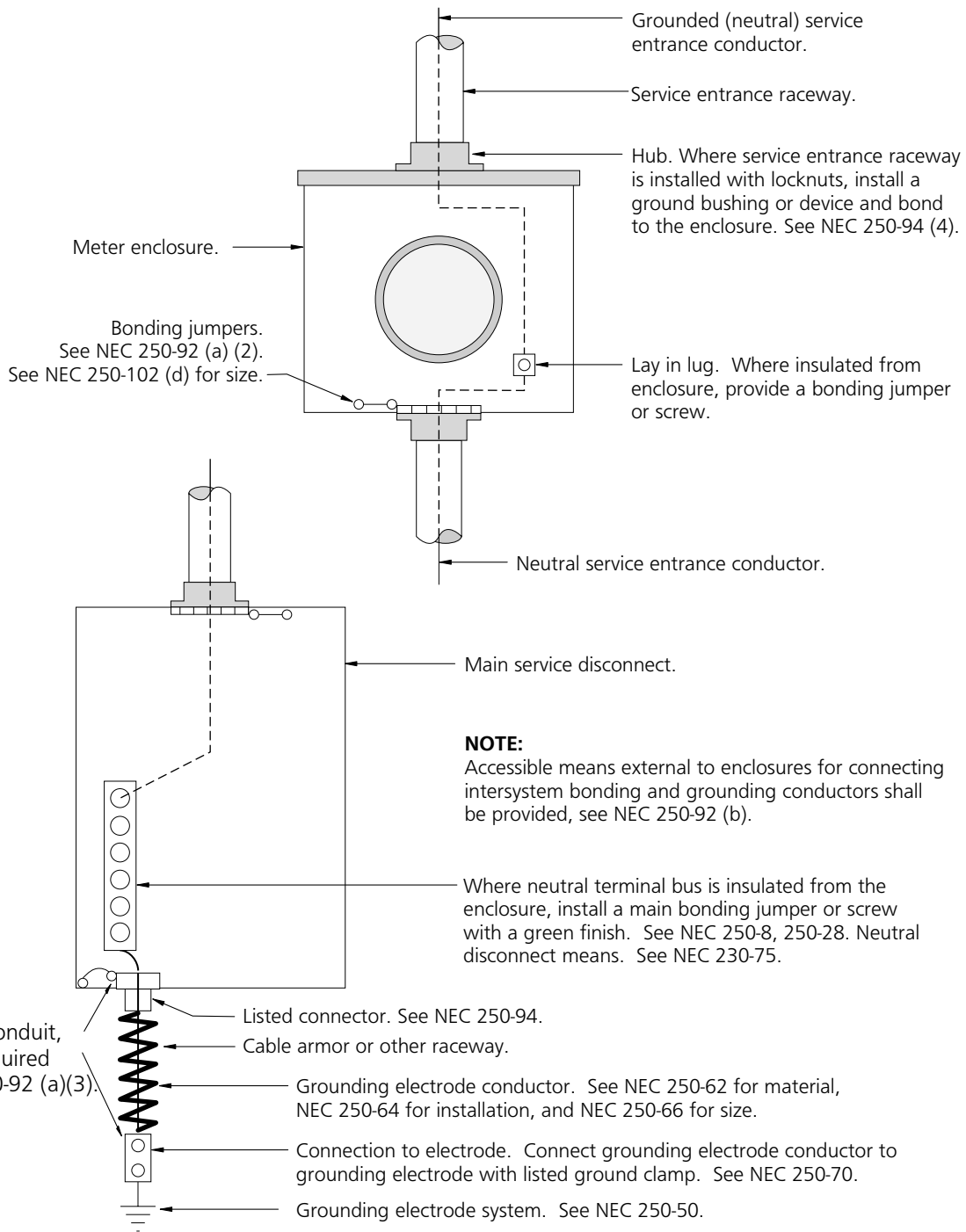

<p>ESR-5</p>	<p>Meters – EXO Installations</p>	<p>REFERENCE NO. <i>PhH</i></p>
<p>PAGE 5-36</p>	<p>Electrical Service Requirements ▶ SCE Public ◀</p>	<p>EFFECTIVE DATE 7-30-2004</p>

Figure 5-19: Meter and Service with Current Transformer Enclosure Overhead Supply

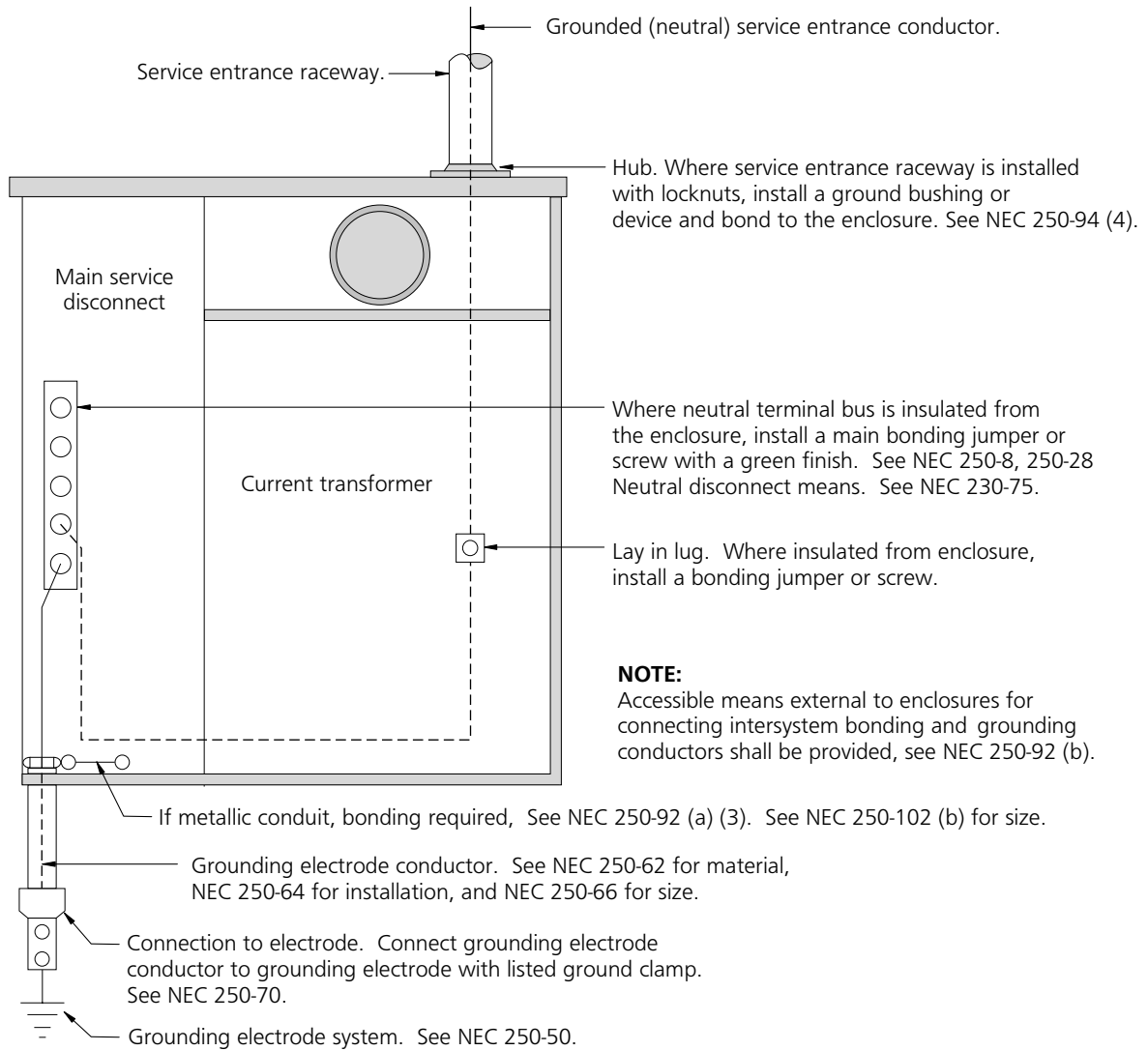

REFERENCE NO. 	Meters – EXO Installations	ESR-5
EFFECTIVE DATE 7-30-2004	Electrical Service Requirements ▶ SCE Public ◀	PAGE 5-37

**Figure 5-20: Single-Meter Commercial Service with a Neutral
 (Where a Main Disconnecting Means is Required)**

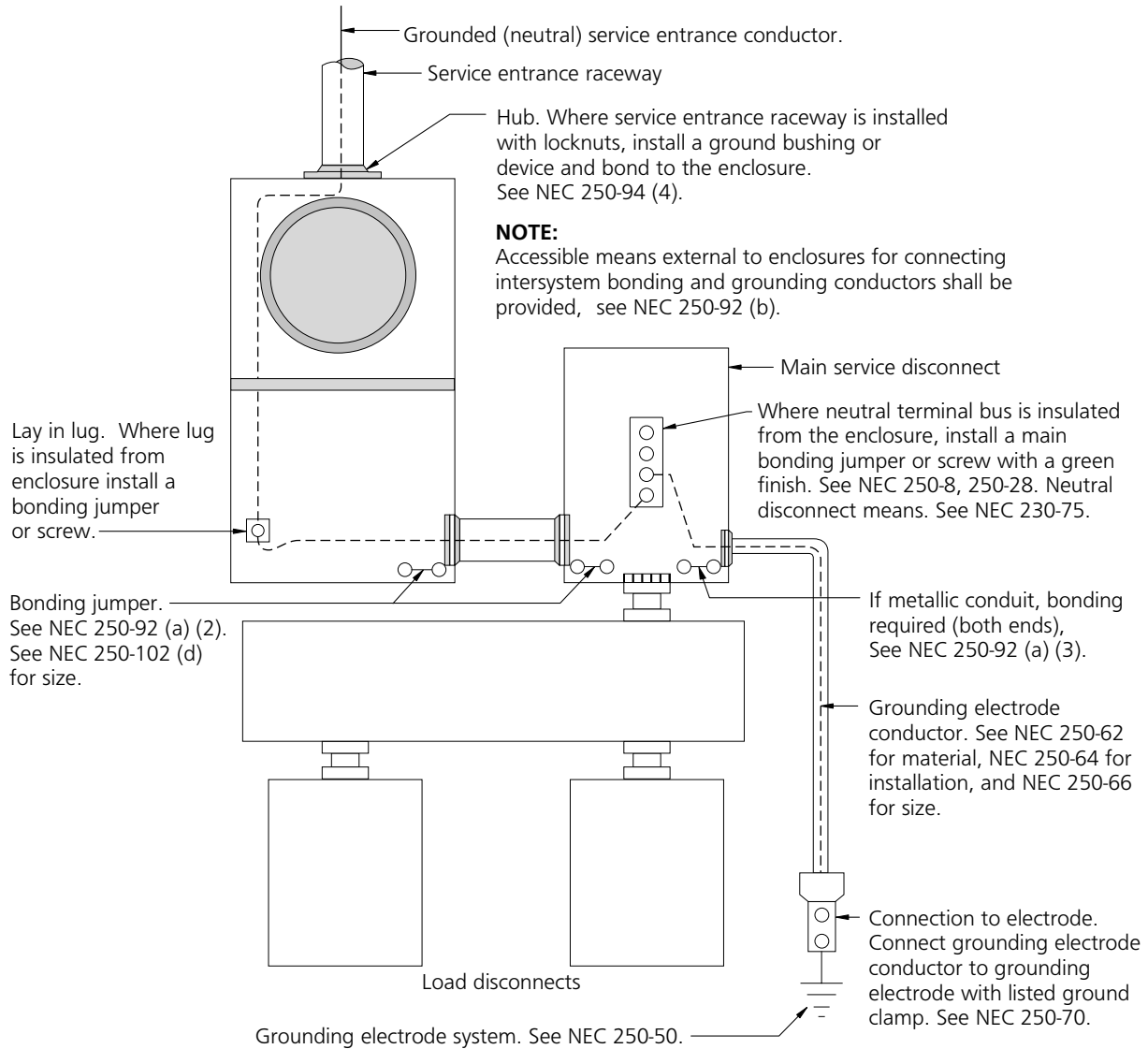

<p>ESR-5</p>	<p>Meters – EXO Installations</p>	<p>REFERENCE NO. <i>PhH</i></p>
<p>PAGE 5-38</p>	<p>Electrical Service Requirements ▶ SCE Public ◀</p>	<p>EFFECTIVE DATE 7-30-2004</p>

Figure 5-21: Three-Phase, Three-Wire Delta Service with Added Grounding Connector^{6/}

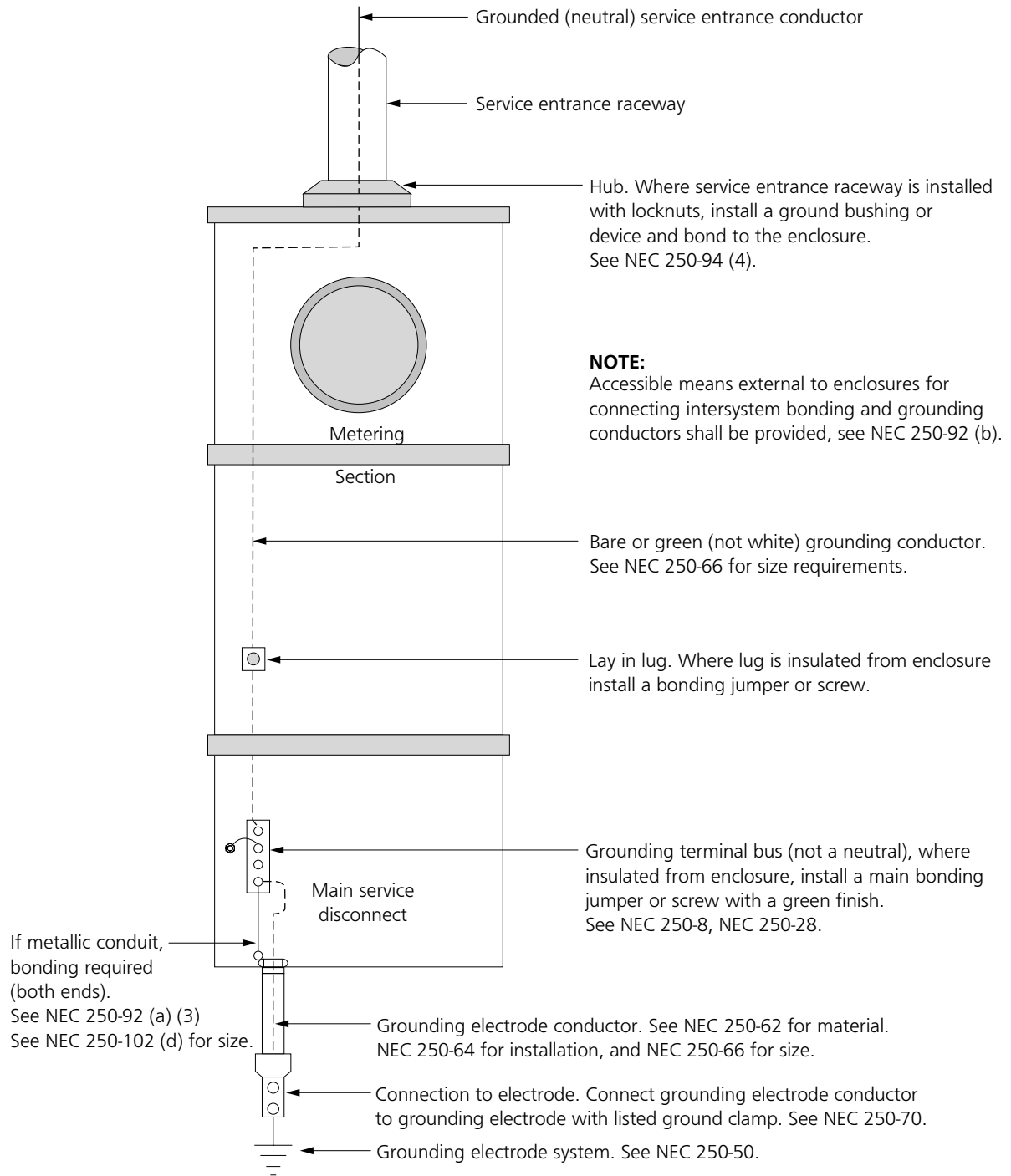

6/ Serving utility MUST be consulted for service transformer connections and transformer grounding to determine appropriate equipment ratings/application.

REFERENCE NO. 	Meters – EXO Installations	ESR-5
EFFECTIVE DATE 7-30-2004	Electrical Service Requirements ▶ SCE Public ◀	PAGE 5-39

Figure 5-22: Commercial Service, Overhead Supply — Six Subdivisions or Less

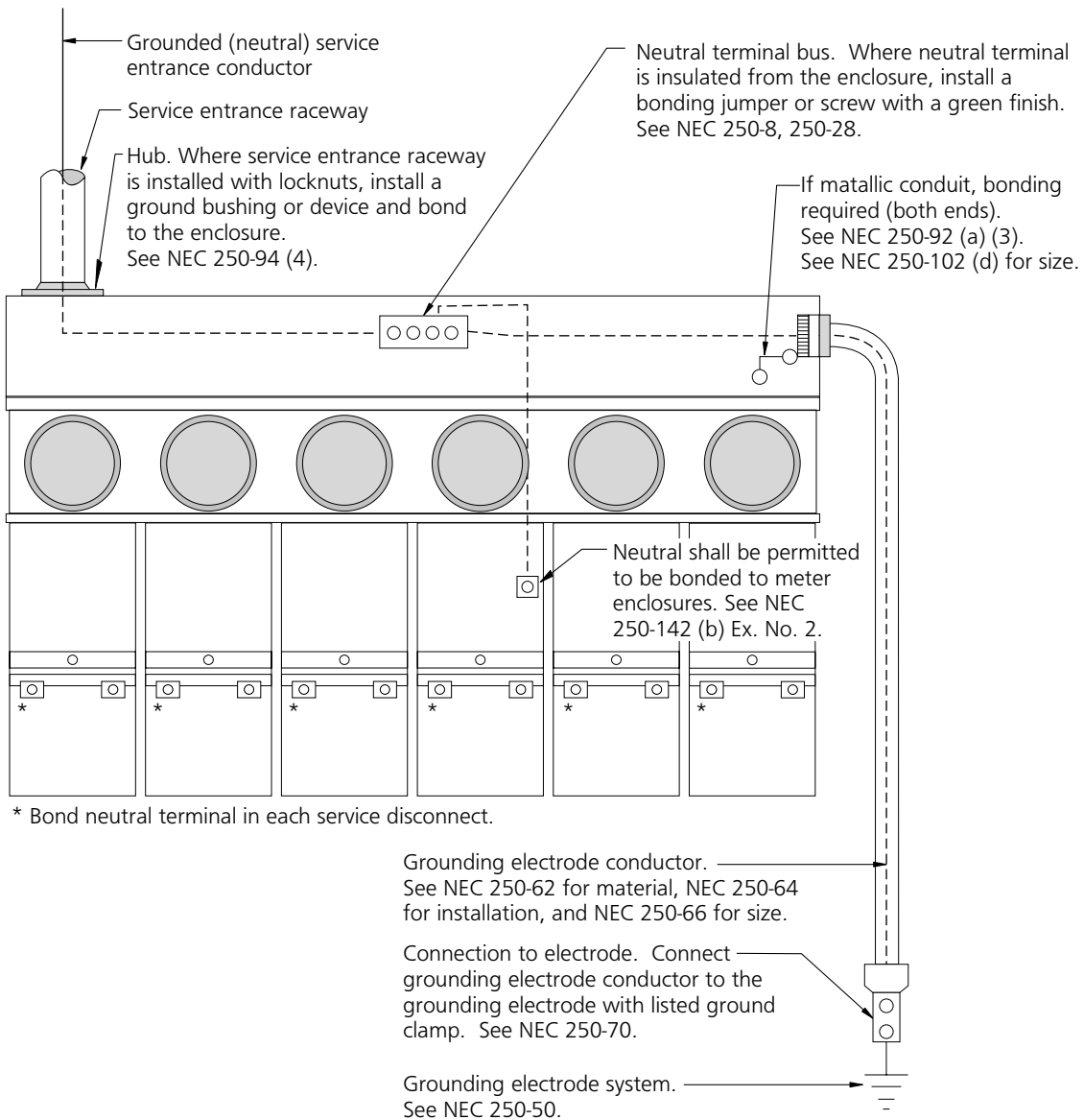

* Bond neutral terminal in each service disconnect.

NOTES:

1. Metallicly isolated water piping systems. See NEC 250-104 (a) (2).
2. Accessible means external to enclosures for connecting intersystem bonding and grounding conductors shall be provided, see NEC 250-92 (b).

ESR-5	Meters — EXO Installations	REFERENCE NO. <i>PhH</i>
PAGE 5-40	Electrical Service Requirements ▶ SCE Public ◀	EFFECTIVE DATE 7-30-2004

Figure 5-23: Commercial Service, Overhead Supply More Than — Six Subdivisions of Service

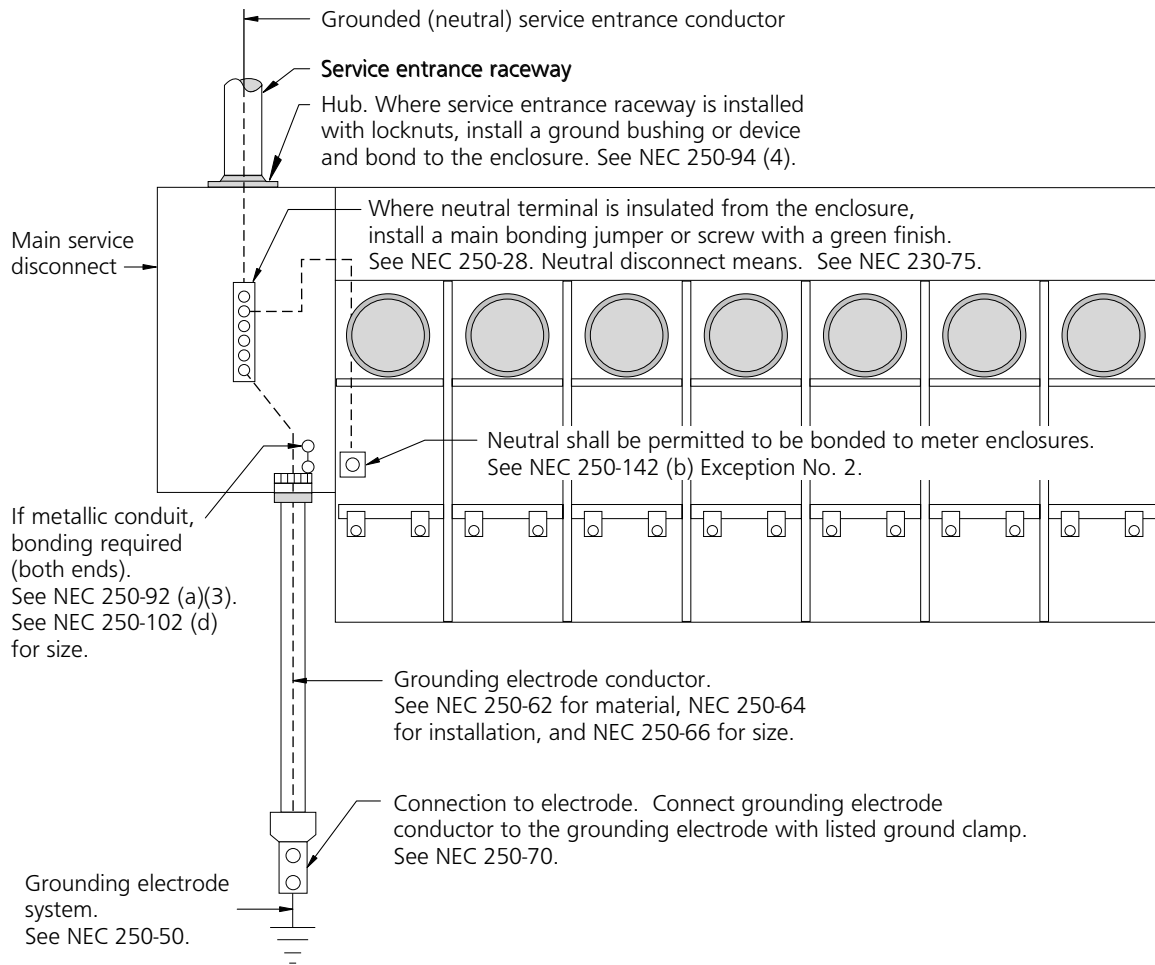

NOTES:

1. Metallically isolated water piping systems. See NEC 250-104 (a) 2).
2. Accessible means external to enclosures for connecting intersystem bonding and grounding conductors shall be provided, see NEC 250-92 (b).

REFERENCE NO. <i>PHH</i>	Meters — EXO Installations	ESR-5
EFFECTIVE DATE 7-30-2004	Electrical Service Requirements ▶ SCE Public ◀	PAGE 5-41

Figure 5-24: Combination Meter and Service For Underground Dwelling Service

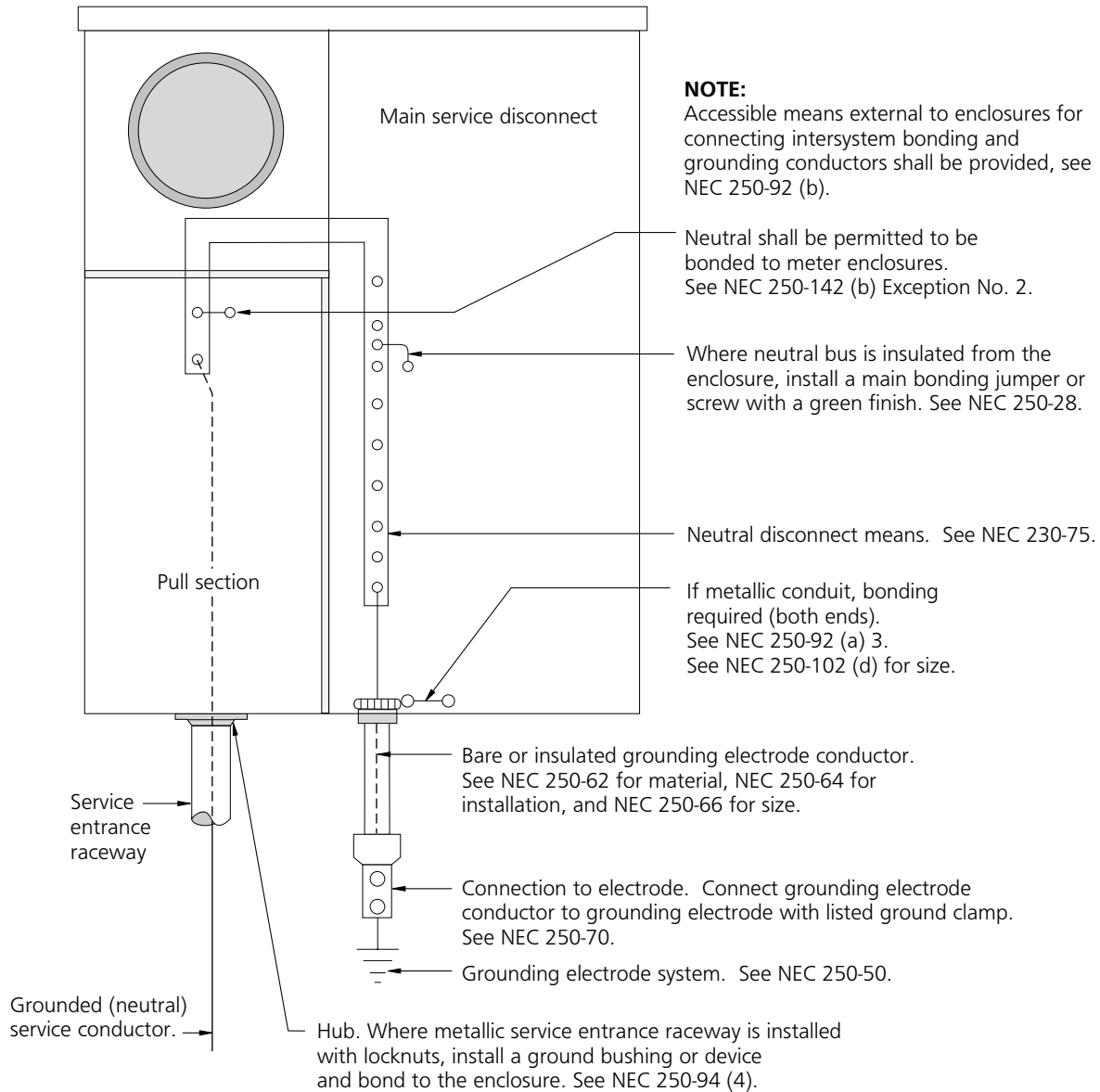

ESR-5	Meters – EXO Installations	REFERENCE NO. <i>PhH</i>
PAGE 5-42	Electrical Service Requirements ▶ SCE Public ◀	EFFECTIVE DATE 7-30-2004

Figure 5-25: Combination Meter and Service For Underground Multi-Family Dwelling Service – Six Subdivisions of Service or Less

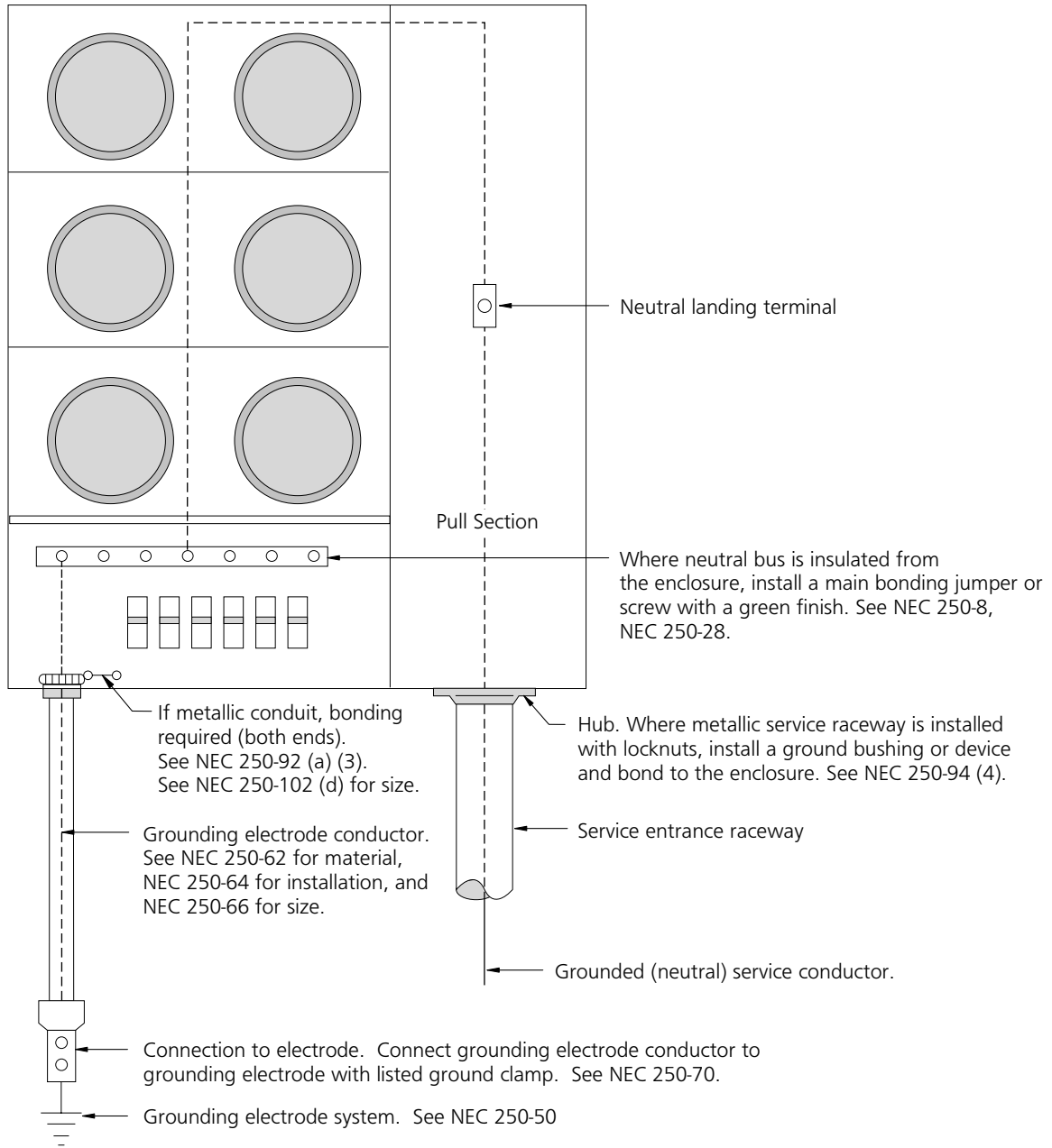

NOTES:

1. Metallically isolated water piping systems. See NEC 250-104 (a) (2).
2. Accessible means external to enclosures for connecting intersystem bonding and grounding conductors shall be provided, see NEC 250-92 (b).

REFERENCE NO. 	Meters – EXO Installations	ESR-5
EFFECTIVE DATE 7-30-2004	Electrical Service Requirements ▶ SCE Public ◀	PAGE 5-43

Figure 5-26: Combination Meter and Service for Underground Multi-Family Dwelling Service – More Than Six Subdivisions

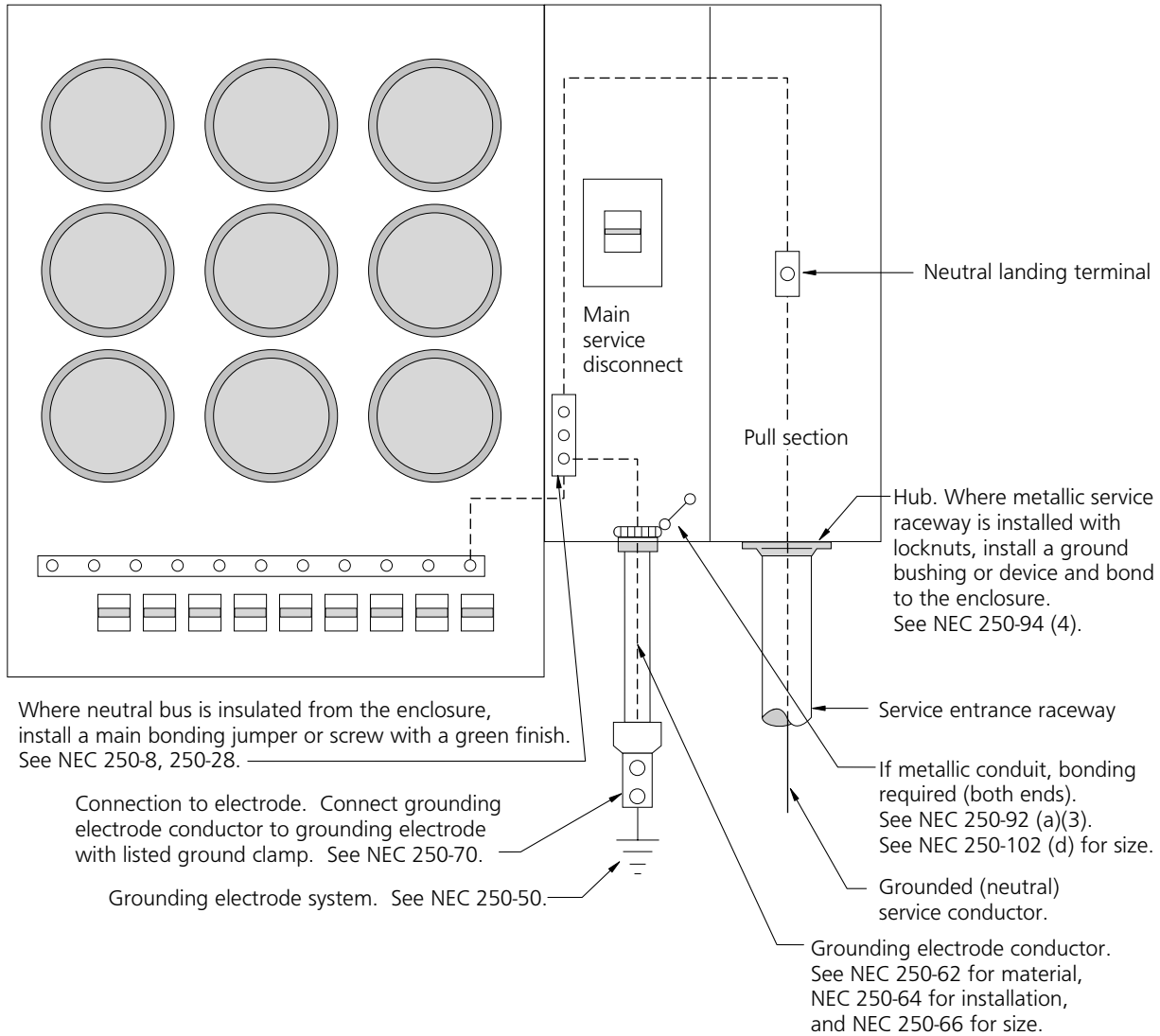

NOTES:

1. Metallically isolated water piping systems. See NEC 250-104 (a) (2).
2. Accessible means external to enclosures for connecting intersystem bonding and grounding conductors shall be provided, see NEC 250-92 (b).

ESR-5	Meters – EXO Installations	REFERENCE NO. <i>PhH</i>
PAGE 5-44	Electrical Service Requirements ▶ SCE Public ◀	EFFECTIVE DATE 7-30-2004

Figure 5-27: Combination Meter and Service for Underground Commercial Service – Six Subdivisions or Less

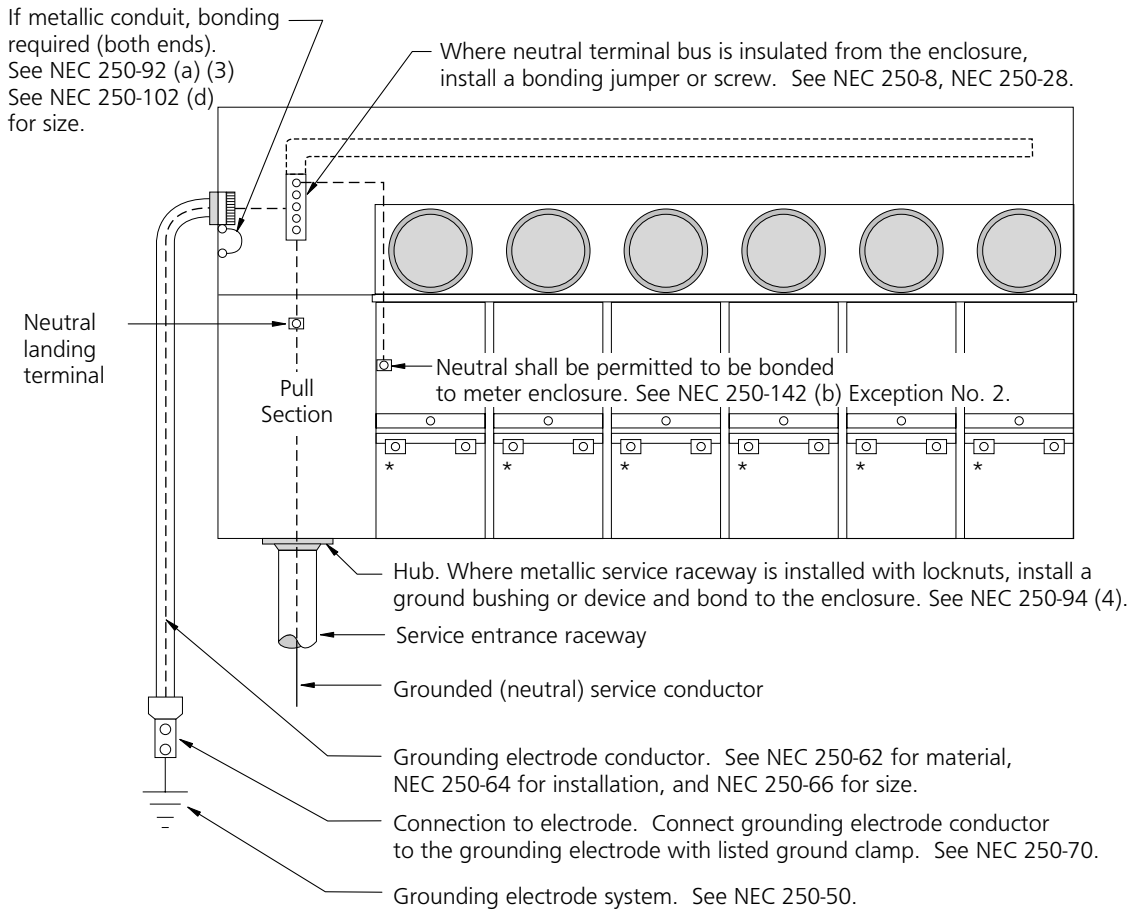

NOTES:

1. Metallically isolated water piping systems. See NEC 250-104 (a) (2).
2. Accessible means external to enclosures for connecting intersystem bonding and grounding conductors shall be provided, see NEC 250-92 (b).

* Bond neutral terminal in each service disconnect.

REFERENCE NO. <i>PHH</i>	Meters – EXO Installations	ESR-5
EFFECTIVE DATE 7-30-2004	Electrical Service Requirements ▶ SCE Public ◀	PAGE 5-45

**Figure 5-28: Combination Meter and Service for Underground Commercial Service
 – More Than Six Subdivisions of Service**

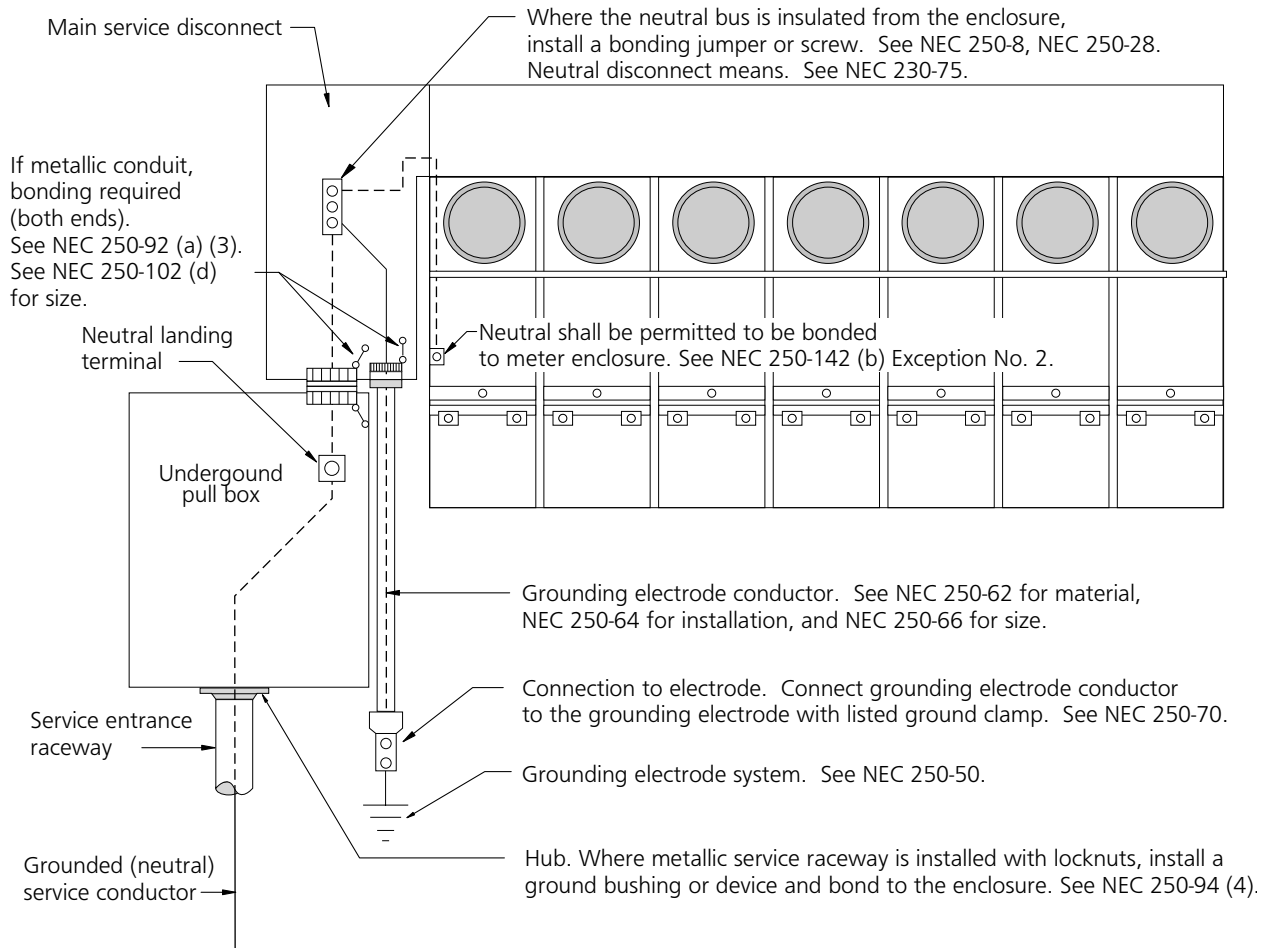

NOTES:

1. Metallicly isolated water piping systems. See NEC 250-104 (a) (2).
2. Accessible means external to enclosures for connecting intersystem bonding and grounding conductors shall be provided, see NEC 250-92 (b).

ESR-5	Meters – EXO Installations	REFERENCE NO. <i>PhH</i>
PAGE 5-46	Electrical Service Requirements ▶ SCE Public ◀	EFFECTIVE DATE 7-30-2004

Figure 5-29: Switchboard Service Section

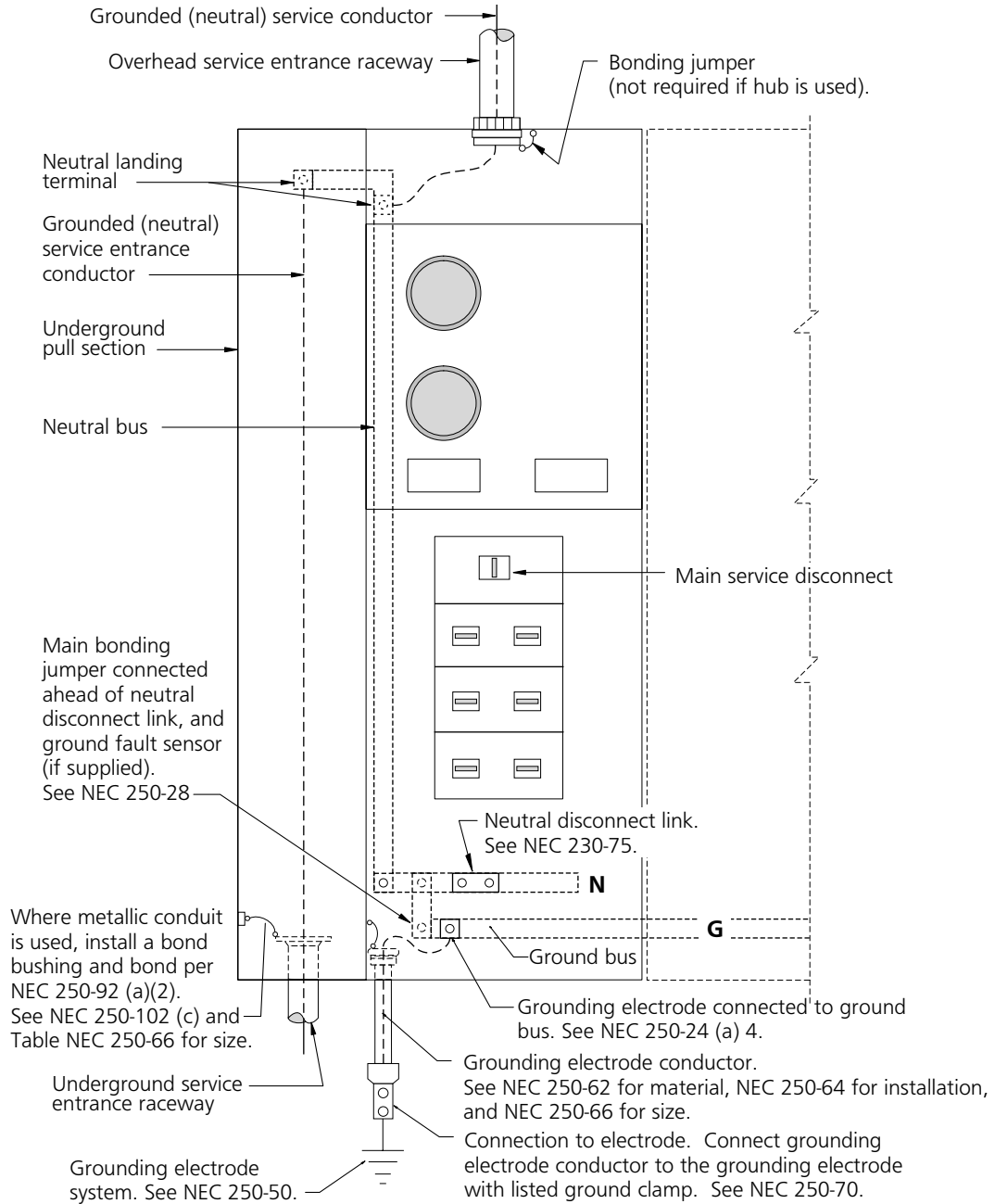

REFERENCE NO. <i>PhH</i>	Meters – EXO Installations	ESR-5
EFFECTIVE DATE 7-30-2004	Electrical Service Requirements ▶ SCE Public ◀	PAGE 5-47

Figure 5-30: Underground Service Post

Note: Accessible means external to enclosures for connecting intersystem bonding and grounding conductors shall be provided, see Section NEC 250-92 (b).

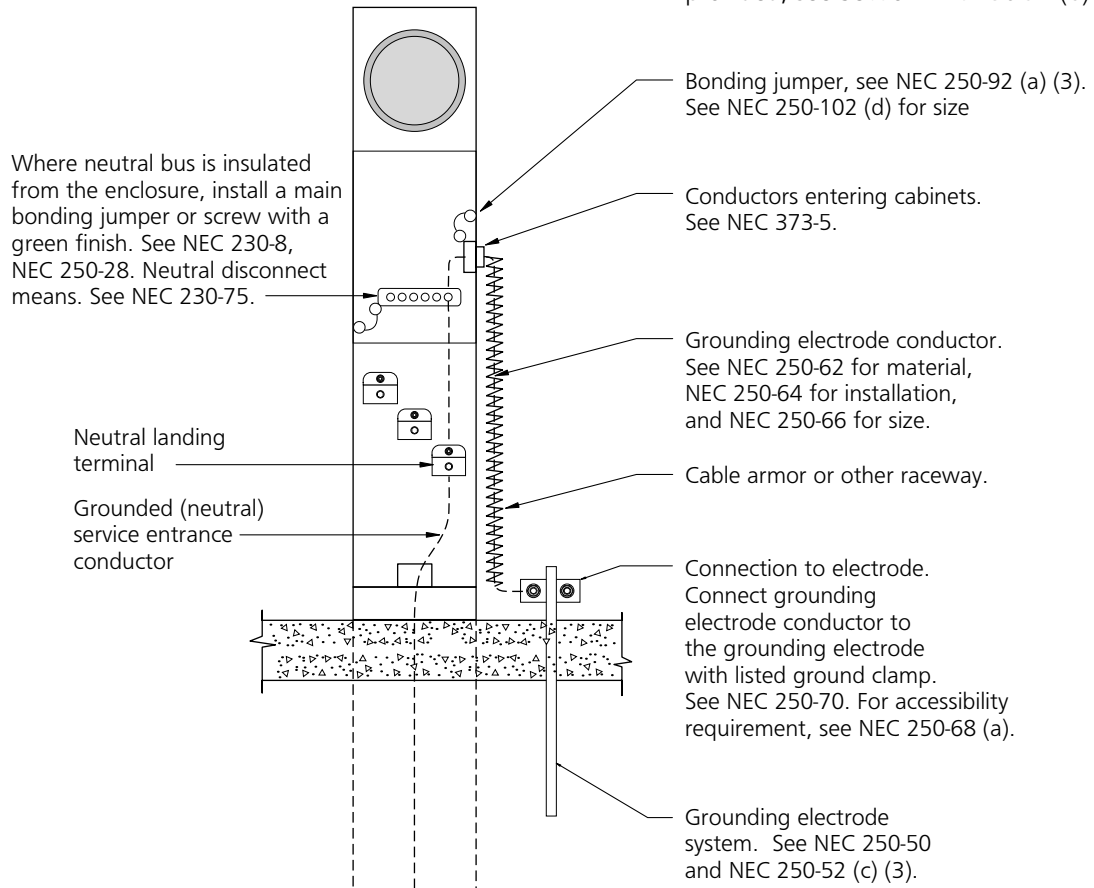

ESR-5	Meters – EXO Installations	REFERENCE NO. <i>PhH</i>
PAGE 5-48	Electrical Service Requirements ▶ SCE Public ◀	EFFECTIVE DATE 7-30-2004

Figure 5-31: Concrete-Encased Electrode (UFER Ground)

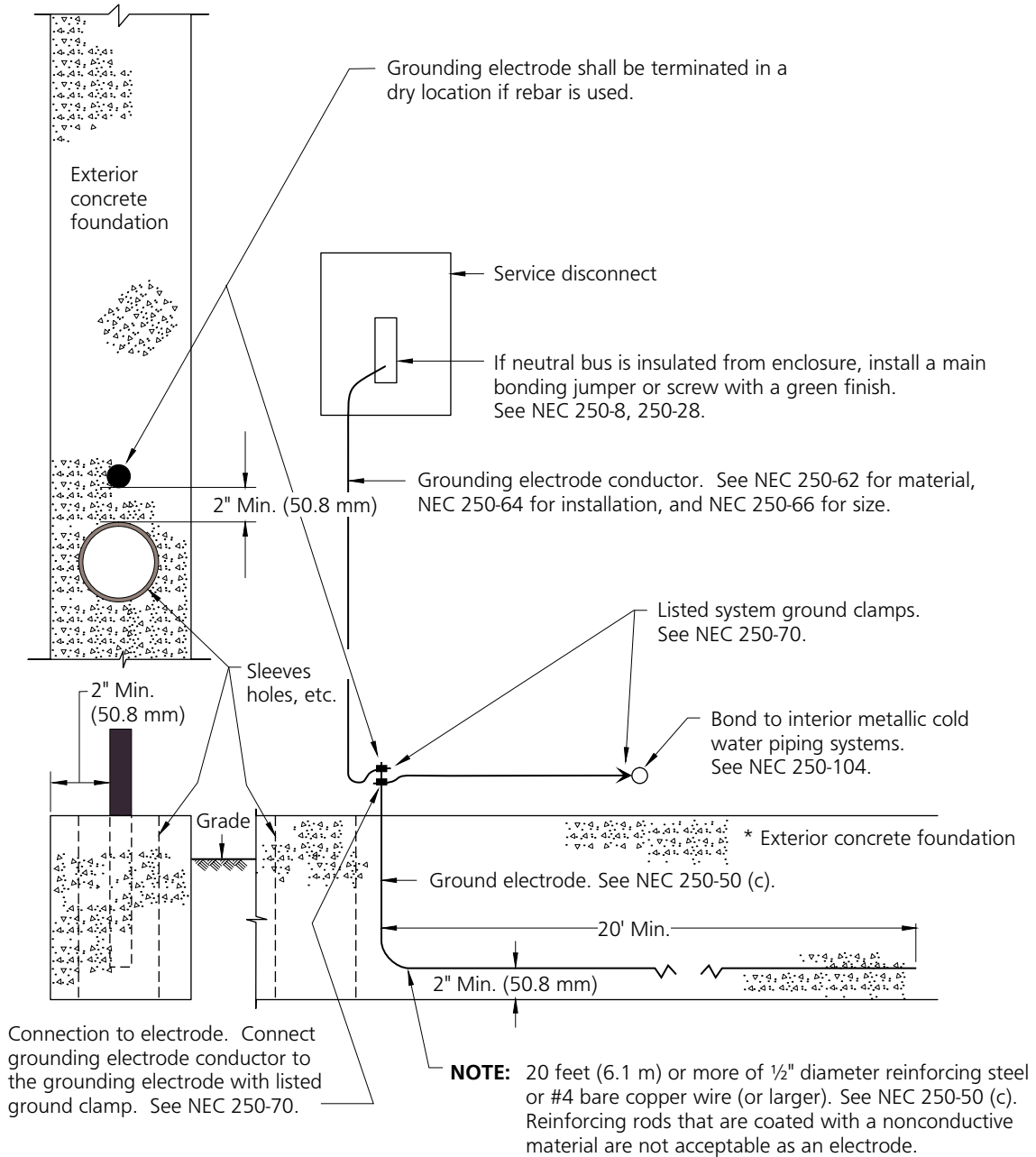

REFERENCE NO. <i>PhH</i>	Meters – EXO Installations	ESR-5
EFFECTIVE DATE 7-30-2004	Electrical Service Requirements ▶ SCE Public ◀	PAGE 5-49

Figure 5-32: Typical Single Phase Customer's Transformer Bonding and Grounding

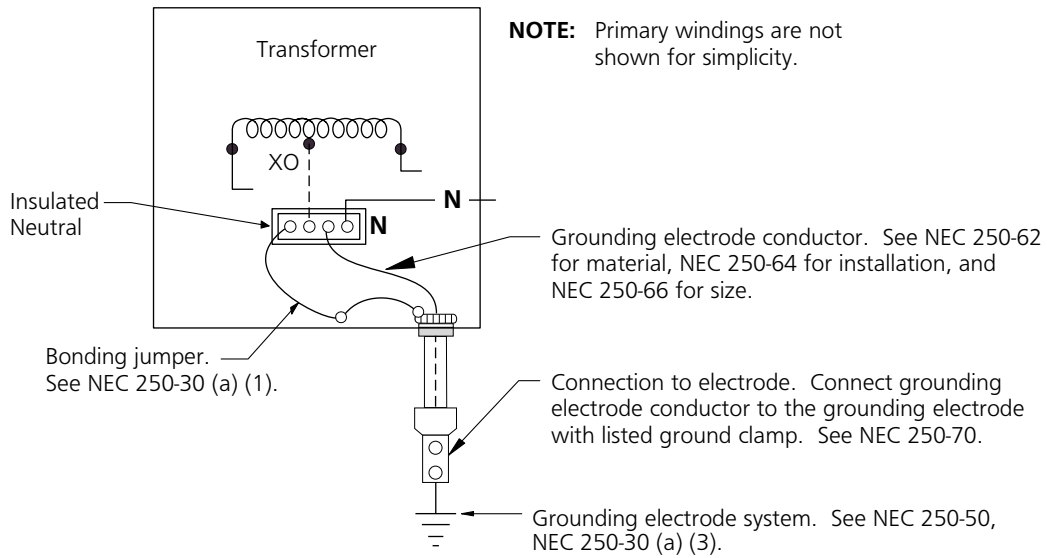

Notes:

1. Primary windings are not shown for simplicity.
2. Grounding & bonding connections as shown above are permitted to be made at any point between the transformer secondary and the first disconnecting means. See NEC 250-30 (a) (1) & (2). Exception No.1 permits bonding at both source and first disconnecting means if no parallel path is established for grounded circuit conductor. Earth is not considered a parallel path.

ESR-5	Meters – EXO Installations	REFERENCE NO. <i>PhH</i>
PAGE 5-50	Electrical Service Requirements ▶ SCE Public ◀	EFFECTIVE DATE 7-30-2004

Figure 5–33: Typical Three Phase Four Wire Wye, Customer’s Transformer Bonding and Grounding

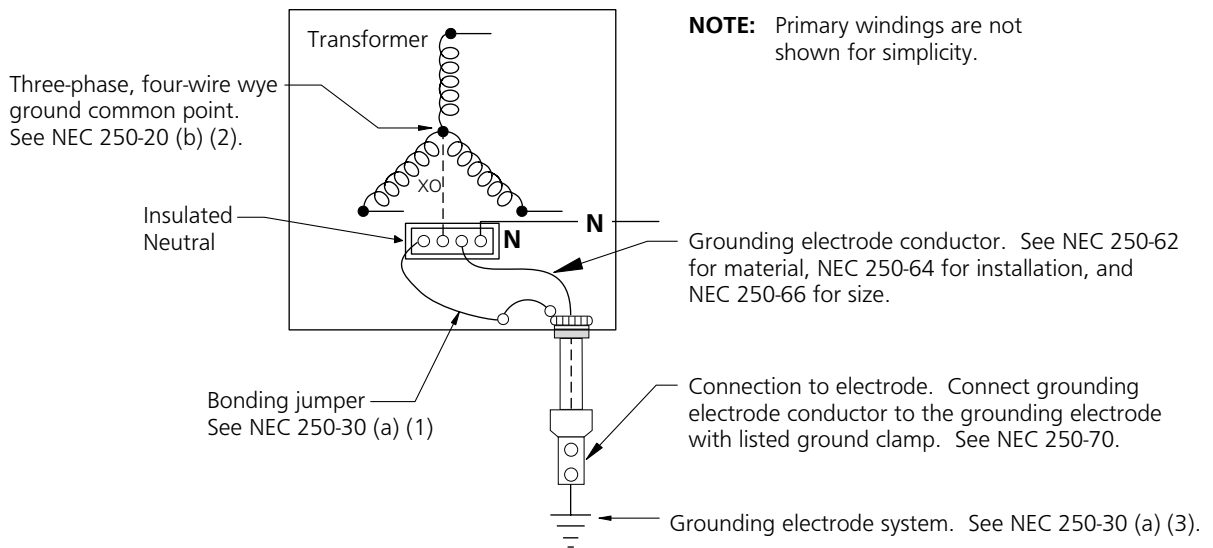

NOTE: Primary windings are not shown for simplicity.

Notes:

1. Primary windings are not shown for simplicity.
2. Grounding & bonding connections as shown above are permitted to be made at any point between the transformer secondary and the first disconnecting means. See NEC 250-30 (a) (1) & (2). Exception No.1 permits bonding at both source and first disconnecting means if no parallel path is established for grounded circuit conductor. Earth is not considered a parallel path.

REFERENCE NO. 	Meters – EXO Installations	ESR–5
EFFECTIVE DATE 7-30-2004	Electrical Service Requirements ▶ SCE Public ◀	PAGE 5–51

Figure 5-34: Typical Three Phase Four Wire Delta, Customer's Transformer Bonding and Grounding

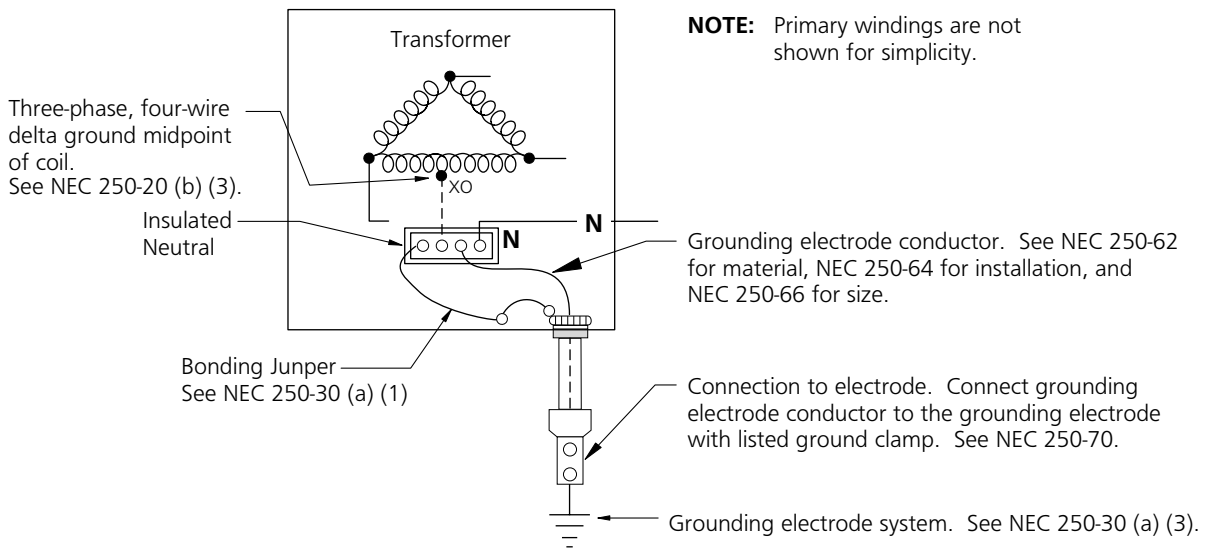

Notes:

1. Primary windings are not shown for simplicity.
2. Grounding & bonding connections as shown above are permitted to be made at any point between the transformer secondary and the first disconnecting means. See NEC 250-30 (a) (1) & (2). Exception No. 1 permits bonding at both source and first disconnecting means if no parallel path is established for grounded circuit conductor. Earth is not considered a parallel path.

ESR-5	Meters – EXO Installations	REFERENCE NO. <i>PhH</i>
PAGE 5-52	Electrical Service Requirements ▶ SCE Public ◀	EFFECTIVE DATE 7-30-2004

Figure 5-35: High-Impedance Grounded Neutral System (NEC Section 250-36)

All of conditions (1), (2), (3), and (4) must be met:

- (1) Qualified persons.
- (2) Continuity of power is required.
- (3) Ground detectors are installed.
- (4) No line-to-neutral loads are served.

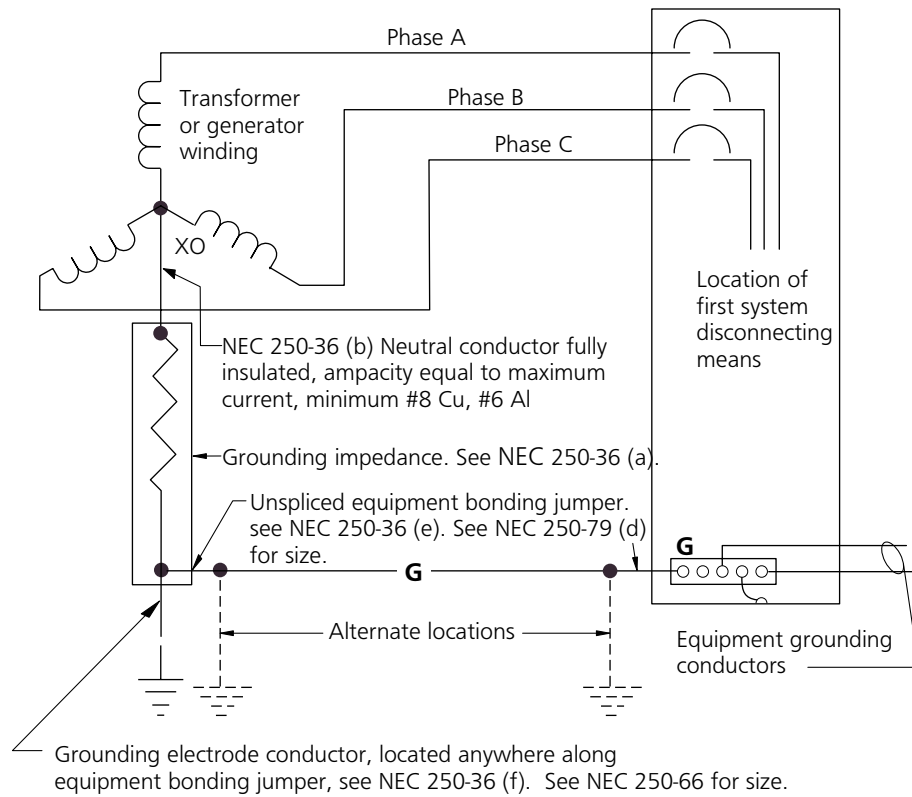

REFERENCE NO. 	Meters – EXO Installations	ESR-5
EFFECTIVE DATE 7-30-2004	Electrical Service Requirements ▶ SCE Public ◀	PAGE 5-53

SWITCHBOARDS 600
VOLTS AND BELOW

ESR-6

ESR-6

SWITCHBOARDS 600 VOLTS AND BELOW

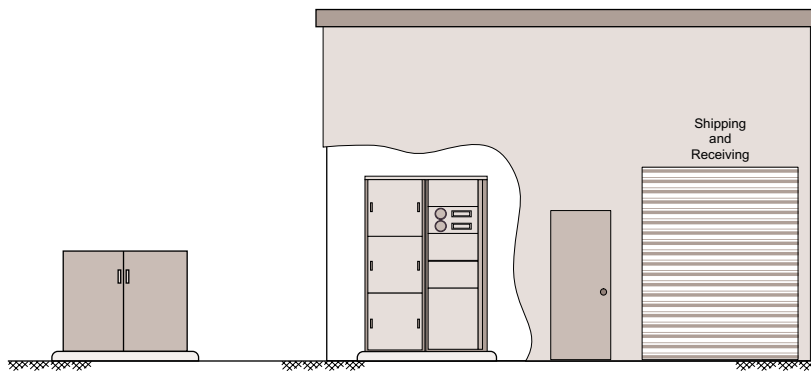

TDBU
▶ **SCE Public** ◀

 **SOUTHERN CALIFORNIA
EDISON®**
An *EDISON INTERNATIONAL*® Company

**SOUTHERN CALIFORNIA EDISON
TDBU**

ESR-6: Switchboards 600 Volts and Below

TABLE OF CONTENTS

Section No.	Title	Page
1.0	Switchboards 600 Volts and Below	6-3
2.0	Grounding and Bonding	6-4
3.0	Instrument Transformer Compartments.	6-4
4.0	Meters and Meter Panels	6-4
5.0	Totalized Services	6-5
6.0	Overhead Service Connections	6-5
7.0	Underground Service Connections	6-5
8.0	Moisture	6-5
9.0	Service Entrance Conductors.	6-5
10.0	Termination Points	6-5
11.0	Switchboard Locations	6-6

LIST OF TABLES

Table No.	Title	Page
6-1	Minimum Pull Section Dimensions.	6-14
6-2	Number of Service Conduits for Commercial/Industrial Underground Pull Sections.	6-15
6-3	Maximum Allowable Bus Size	6-25

APPROVED 	Switchboards 600 Volts and Below	ESR-6
EFFECTIVE DATE 1-11-2002	Electrical Service Requirements ▶ SCE Public ◀	PAGE 6-1

LIST OF FIGURES

Figure No.	Title	Page
6-1	Standard Switchboard Service Section with Instrument–Transformer Compartment 0–600 Volts	6-7
6-2	Standard Switchboard Service Section with Instrument–Transformer Compartment and Filler Panel 0–600 Volts	6-8
6-3	Combination Switchboard Service Section and Pull Section 0–600 Volts, 2000 Amperes Maximum	6-9
6-4	Outdoor or Rain tight enclosures for Switchboards 0–600 Volts	6-10
6-5	Overhead Service Termination Standard Switchboard Service Section 0–600 Volts.	6-11
6-6	Underground Service Terminating Facilities in Pull Boxes or Pull Sections, 0–600 Volts . . .	6-12
6-7	Underground Service Termination Standard Switchboard Service Section 400 to 4000 Amp, 0–600 Volts	6-14
6-8	Instrument–Transformer Compartment for Switchboards 0–1,000 Amps Maximum, 0–600 Volts Single- or Three- Phase Three-Wire	6-16
6-9	Instrument–Transformer Compartment for Switchboards 0–1000 Amperes, 0–600 Volts Three Phase Four-Wire.	6-18
6-10	Instrument–Transformer Compartment for Switchboards 1001–3000 Amperes, 0–600 Volts Three Phase Four-Wire	6-20
6-11	Removable Link and Current–Transformer Support for Instrument–Transformer Compartments with 4-inch Bus 0–600 Volts	6-22
6-12	15-Inch Hinged Meter Panel 0–600 Volts.	6-23
6-13	Instrument–Transformer Compartment for Switchboards 3001–4000 Amperes, 0–600 Volts Three Phase Four-Wire	6-25
6-14	Removable Link and Current–Transformer Support for Instrument–Transformer Compartments with 5-inch Bus 0–600 Volts	6-27
6-15	Self-Contained Meters Installed in Switchboards 0–200 Amps 0–600 Volts	6-28
6-16	Clearances for Residential Multiple Metering Installations	6-30
6-17	30-Inch Hinged Dual Socket Meter Panel 0–600 Volts.	6-32

ESR-6	Switchboards 600 Volts and Below	APPROVED <i>PhH</i>
PAGE 6-2	Electrical Service Requirements ▶ SCE Public ◀	EFFECTIVE DATE 1-11-2002

1.0 Switchboards 600 Volts and Below

The following requirements are intended to be in general agreement with the switchboard requirements of the Electric Utility Service Equipment Requirements Committee (EUSERC). Before any switchboard is fabricated or installed, the manufacturer shall submit **three copies** of the switchboard drawings to the local Service Planning office for review and approval. See [ESR-1: Table 1-1 "Service Planning Office – Phone Numbers & Locations"](#) for office locations.

For the purposes of these requirements, switchboard service sections are those sections containing an area for incoming service entrance conductors, instrument transformer or test by-pass compartments, panels for mounting meters or associated equipment, and meter (service) switch(es), breaker(s) or main disconnect(s).

Switchboard service sections are preferred to EXO instrument transformer cabinet installations, see [ESR-5: Section 10.0 "Current Transformer Cabinet & Meter Socket Panel"](#), [ESR-5: Figure 5-12](#) through [ESR-5: Figure 5-16](#) for services rated 201 - 400 amperes switchboard service sections are required for services in excess of 400 amperes. Self contained multiple metering installations (maximum 200 amperes for each meter socket) may also be placed in switchboard service sections. See [Figure 6-15 \(page 6-28\)](#) for details.

Any portion of a switchboard service section that can be removed to give access to unmetered service or service entrance conductors shall be sealable or made non-removable. Where a raceway for meter secondary wiring is required, access points to this raceway shall be sealable.

All side ports between any locations in service sections of switchboards (pull sections/meter sections, etc.), except those occupied by service conductors, and all ports above the level of the main switch/breaker compartment, shall be completely barriered.

Conductors shall not be rerouted through any metering compartment. Fused and unfused conductors shall not occupy the same raceway unless they are completely barriered from each other in a manner acceptable to the Company.

On 120/240 volts, three-phase, four-wire services, the power leg busing (208 volts to ground) through pull sections and instrument transformer compartments, shall be permanently identified by an "orange-color" outer finish, or by other effective means. The power leg in an instrument transformer compartment is the right-hand phase/bus position (C phase). Refer to [ESR-5: Table 5-3](#) for the proper socket terminals for each voltage classification.

On 240 volt three-phase services, the identified grounding conductor routed through the instrument transformer compartment with the phase busing may be busbar or wire. Where wire is used, it shall be routed along the back of the instrument transformer compartment and fastened in place. See [ESR-5: Section 11.0 "Grounding and Bonding"](#) for 240 volt grounding details.

Every meter (service) switch or breaker for an individual meter rated at 600 volts or less shall be on the load side (new sequence) of the meter or metering equipment. A main disconnect shall be permitted on the line side (old sequence) of a group of two to six meters and shall be required for a group of more than six meters (disconnects). See [ESR-1: Section 11.0 "Service or Meter Switch—General Requirements"](#) for meter switch location.

Equipment permitted to be connected ahead of the meter (service) switch or breaker by local codes or ordinances shall not be tapped ahead of metering or anywhere within an instrument transformer compartment. Where a main disconnect is placed on the supply side of a group of meters, any equipment tapped ahead of the metering or disconnect shall be separately metered.

APPROVED 	Switchboards 600 Volts and Below	ESR-6
EFFECTIVE DATE 1-11-2002	Electrical Service Requirements ▶ SCE Public ◀	PAGE 6-3

2.0 Grounding and Bonding

Refer to [ESR-5: Figure 5-17](#) through [ESR-5: Figure 5-35](#) for grounding and bonding requirements.

3.0 Instrument Transformer Compartments

Instrument transformer compartments in switchboard service sections shall be fabricated in accordance with the following requirements:

Service	Ampacity	Page
Single or three phase, three wire services	up to 1,000 amperes	see Figure 6-8 (page 6-16)
Three phase, four wire services	up to 1,000 amperes	see Figure 6-9 (page 6-18)
Three phase, four wire services	1,001 - 3,000 amperes	see Figure 6-10 (page 6-20)
Three phase, four wire services	3,001 - 4,000 amperes	see Figure 6-13 (page 6-25)

4.0 Meters and Meter Panels

All meter sockets shall be furnished and installed by the manufacturer. Screws used to mount cast meter sockets to hinged panels shall provide a 1/8 inch minimum clearance between the screw head and the back of the meter socket ring. Meter sockets installed on hinged panels shall be designed for back connection. Refer to [ESR-5: Table 5-3](#) and [ESR-5: Figure 5-2](#) for meter socket terminal arrangements.

The maximum meter socket height measured from the center of the socket to the **standing and working surface** is six foot, three inches. The minimum height is four feet for exposed meters and three feet for enclosed meters or meters in meter rooms.

Meter panels shall be constructed of a minimum of twelve gauge steel and shall be hinged and sealable. Hinges shall be readily interchangeable, right or left, on the job site. Where clevis-type or removable pin-type hinges are used, provisions shall be made so that the pin can be removed from the top. Hinges must support the minimum of a 25 pound load applied to the unsupported end of the panel with a one-eighth inch maximum sag when open. Meter panels shall not be hinged to filler panels. Filler panels shall be hinged to provide a full access opening to the instrument transformer compartment. Hinged panels shall be capable of being opened a full 90 degrees with all metering equipment in place. Enclosed meter panels may require wider access openings to permit 90 degree opening. See [Figure 6-4 \(page 6-10\)](#).

Meter panels fabricated in accordance with [Figure 6-17 \(page 6-32\)](#) shall be provided for service sections rated as follows:

120/208 volts - 800 amperes and above
240 volts - 600 amperes and above
277/480 volts - 400 amperes and above

All other service sections shall have meter panels fabricated in accordance with [Figure 6-12 \(page 6-23\)](#).

For meter and meter panel requirements on self-contained, multiple metering installations, see [Figure 6-15 \(page 6-28\)](#).

ESR-6	Switchboards 600 Volts and Below	APPROVED <i>PhH</i>
PAGE 6-4	Electrical Service Requirements ▶ SCE Public ◀	EFFECTIVE DATE 1-11-2002

5.0 Totalized Services

Where two or more switchboard service sections are required to be totalized, see [ESR-2: Section 2.1](#), [ESR-2: Section 2.6](#), [ESR-3: Section 2.1](#) and [ESR-3: Section 3.2](#), their instrument transformer compartments shall not be more than 20 feet apart (unobstructed walking distance). With the approval of the local Service Planning office, service sections which are a part of a contiguous switchgear line-up, in a single meter room, may be separated by more than 15 feet (unobstructed walking distance). The customer is to provide and install a 1-1/4 inch conduit run between instrument transformer compartments to be totalized. Meter panels on totalized switchboard sections shall be fabricated in accordance with [Figure 6-17 \(page 6-32\)](#) unless otherwise specified.

6.0 Overhead Service Connections

The service entrance conductors from the point of service delivery to the point of attachment in the switchboard service section shall be furnished and installed by the customer. See [ESR-2: Section ESR-2: "Overhead Service Connections 0-600 Volts"](#) and [ESR-4: Section ESR-4: "Company Owned Transformers on Customer's Premises"](#) for details. The customer is responsible for terminating the service entrance conductors to the switchboard bus.

7.0 Underground Service Connections

A separate terminating pull section, [Figure 6-7 \(page 6-14\)](#), wall mounted terminating pull box, [ESR-3: Figure 3-9](#) or subsurface type pull box, [ESR-3: Figure 3-22](#), shall be provided on every underground service from either an overhead or underground source. Terminating pull sections are preferred.

8.0 Moisture

Pull sections, pull boxes and switchboard service sections shall be located so that any moisture which might enter the pull section or pull box from underground service conduits cannot run into the service section, either directly or through conduits/raceways. Where the service section is installed at a level lower than that of the service conduits, a blank pull section shall be installed in addition to the termination enclosure/section. Both ends of all conduits shall be sealed to prevent moisture from entering the termination enclosure/section. At no time may service lateral conduit(s) terminate above service entrance bus or in a current transformer compartment.

9.0 Service Entrance Conductors

Where the pull section or pull box is not attached to the switchboard service section, the customer shall furnish and install service entrance conductors from the pull section or pull box to the service section. The customer is responsible for terminating the service entrance conductors to the service entrance or current transformer bus, see [Figure 6-7 \(page 6-14\)](#), Exhibit B.

10.0 Termination Points

Lug landings shall be provided in switchboard pull sections and wall mounted pull boxes, see [Figure 6-6 \(page 6-12\)](#) and [Figure 6-7 \(page 6-14\)](#). The number of lug landing positions required per phase will be designated by the Company. The Company will furnish and install terminating lugs on it's service lateral cables and attach same to the lug landings.

APPROVED 	Switchboards 600 Volts and Below	ESR-6
EFFECTIVE DATE 1-11-2002	Electrical Service Requirements ▶ SCE Public ◀	PAGE 6-5

11.0 Switchboard Locations

Switchboards shall be located so that the meters have the required clearances from side walls, ceilings and other obstructions, and so that the requirements of **ESR-5: Section 6.0 "Meter Locations"** and **ESR-5: Table 5-2 "Prohibited Meter Locations"** are complied with. See **ESR-3: Section 15.0 "Terminating Enclosures"** for additional requirements affecting terminating enclosures and switchboard locations.

ESR-6	Switchboards 600 Volts and Below	APPROVED <i>PhH</i>
PAGE 6-6	Electrical Service Requirements ▶ SCE Public ◀	EFFECTIVE DATE 1-11-2002

Figure 6-1: Standard Switchboard Service Section with Instrument—Transformer Compartment 0–600 Volts

EUSER DRAWING NO. 325

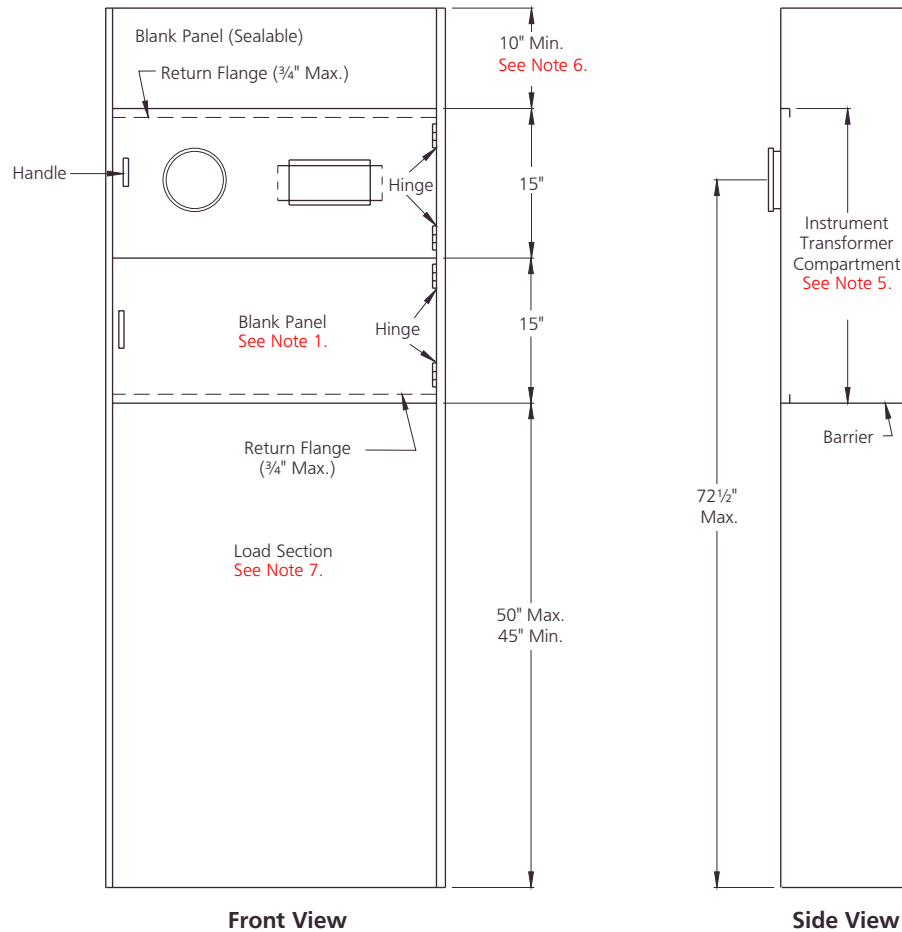

Notes

1. Socket meter panel with blank meter panel shown. Consult the Company regarding alternate meter panel arrangements. Blank meter panel shall be constructed of 12 gauge (minimum) steel. See Figure 6-12 (page 6-23) and Figure 6-17 (page 6-32) for socket meter panel details.
2. Meter panels shall be equipped with stops to prevent inward swinging beyond the front surface of the service section.
3. Hinges shall be readily interchangeable, left or right, on the job site.
4. Removable or hinged panels enclosing unmetrated bus or cable shall be sealable. All securing screws shall be captive.
5. For requirements regarding instrument—transformer compartments, see; 0 to 100 Amperes Figure 6-8 (page 6-16) & Figure 6-9 (page 6-18), 1001 to 3000 Amperes Figure 6-10 (page 6-20), 3001 to 4000 Amperes Figure 6-13 (page 6-25).
6. Dimension may be reduced if the service section is supplied from horizontal cross-busing or bus duct.
7. When used as utility terminating section in a bottom-fed service section, see Figure 6-3 (page 6-9).
8. For outdoor applications see Figure 6-4 (page 6-10) for weatherproof enclosure requirements.

APPROVED 	Switchboards 600 Volts and Below	ESR-6
EFFECTIVE DATE 1-11-2002	Electrical Service Requirements ► SCE Public ◀	PAGE 6-7

Figure 6-2: Standard Switchboard Service Section with Instrument-Transformer Compartment and Filler Panel 0-600 Volts

EUSER DRAWING NO. 326

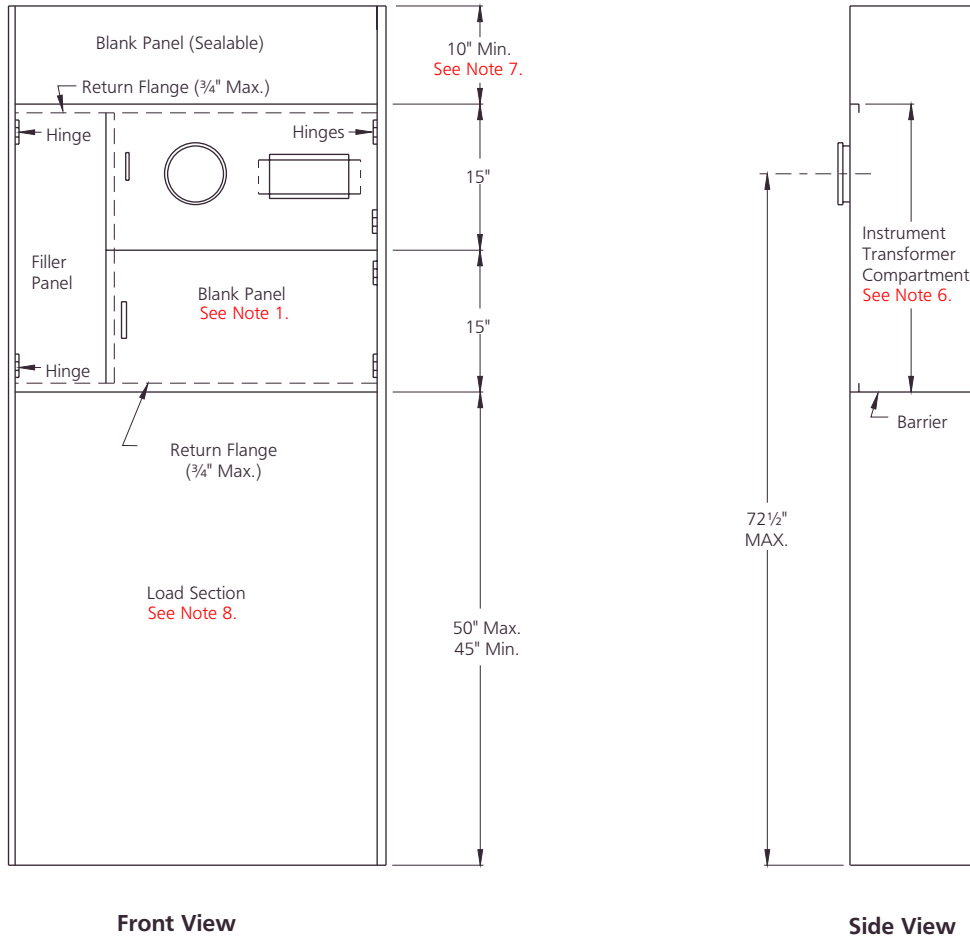

Notes

1. Socket meter panel with blank meter panel shown. Consult the Company regarding alternate meter panel arrangements. Blank meter panel shall be constructed of 12 gauge (minimum) steel. See Figure 6-12 (page 6-23) and Figure 6-17 (page 6-32) for socket meter panel details.
2. Filler panels shall be used where the service section width exceeds the meter panel width. Meter panels, either socket or blank, shall not be hinged to hinged filler panels. Nonhinged filler panels shall not extend into the required instrument-transformer compartment access opening.
3. Meter panels and filler panels shall be equipped with stops to prevent inward swinging beyond the front surface of the service section.
4. Hinges shall be readily interchangeable, left or right, on the job site.
5. Removable or hinged panels enclosing unmetrated bus or cable shall be sealable. All securing screws shall be captive.
6. For requirements regarding instrument-transformer compartments, see; 0 to 100 Amperes Figure 6-8 (page 6-16) & Figure 6-9 (page 6-18), 1001 to 3000 Amperes Figure 6-10 (page 6-20), 3001 to 4000 Amperes Figure 6-13 (page 6-25).
7. Dimension may be reduced if the service section is supplied from horizontal cross-busing or bus duct.
8. When used as utility terminating section in a bottom-fed service section, see Figure 6-3 (page 6-9)
9. For outdoor applications see Figure 6-4 (page 6-10) for weatherproof enclosure requirements.

ESR-6	Switchboards 600 Volts and Below	APPROVED <i>PhH</i>
PAGE 6-8	Electrical Service Requirements ▶ SCE Public ◀	EFFECTIVE DATE 1-11-2002

Figure 6–3: Combination Switchboard Service Section and Pull Section 0–600 Volts, 2000 Amperes Maximum

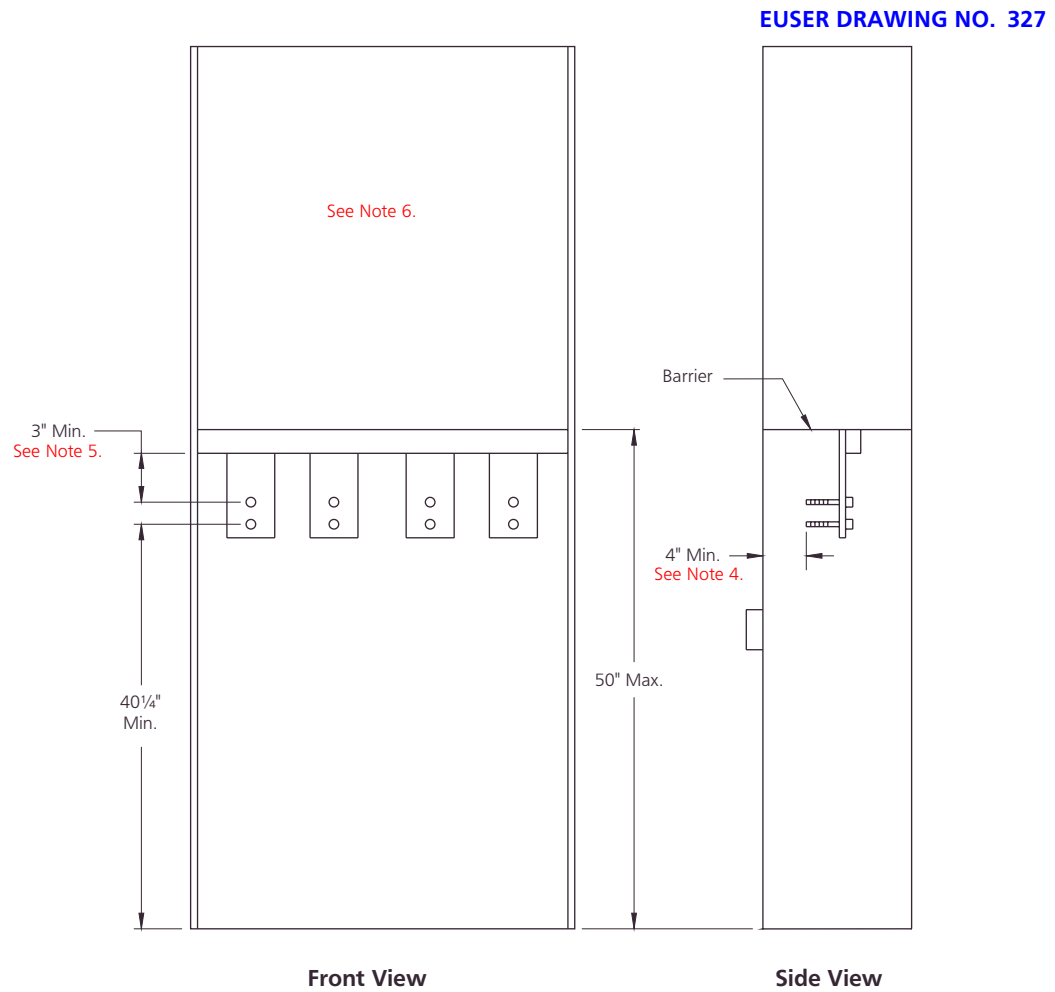

Notes

1. The pull section may supply either a current–transformer compartment or a main service disconnect device.
2. Pull section covers shall be:
 - a. Independent of other equipment and removable without disturbing adjacent panels.
 - b. Sealable, provided with two lifting handles, and limited to a maximum of 9 square feet in area.
3. The pull section shall be equipped with terminating facilities complying with Figure 6–6 (page 6–12). Terminating facilities shall be secured to prevent misalignment and shall be rigid without the installation of current transformers.
4. The clearance from the energized bus to the pull section removable access covers may be reduced if a safety barrier is provided by the manufacturer. For addition clearance and barrier requirements, see Note 9 (page 6–15).
5. A vertical clearance of 3 inches minimum shall be maintained between the centerline of the top bolts of the terminating facilities to any obstruction.
6. When the upper section is an instrument–transformer compartment, see Figure 6–2 (page 6–8) for additional service section requirements. When the upper section is a main service disconnect device a full width and depth, insulated, rigid barrier shall be provided to separate the pull section and main service disconnect compartment. In addition, the main service disconnect cover shall be sealable.
7. Sealing provisions for removable covers shall consist of two drilled stud and wing-nut assemblies located on opposite sides of the cover. Hinged covers shall be sealed on the unsupported side. All security screws shall be captive.

APPROVED 	Switchboards 600 Volts and Below	ESR–6
EFFECTIVE DATE 1-11-2002	Electrical Service Requirements ▶ SCE Public ◀	PAGE 6–9

Figure 6-4: Outdoor or Rain tight enclosures for Switchboards 0-600 Volts

EUSER DRAWING NO. 354

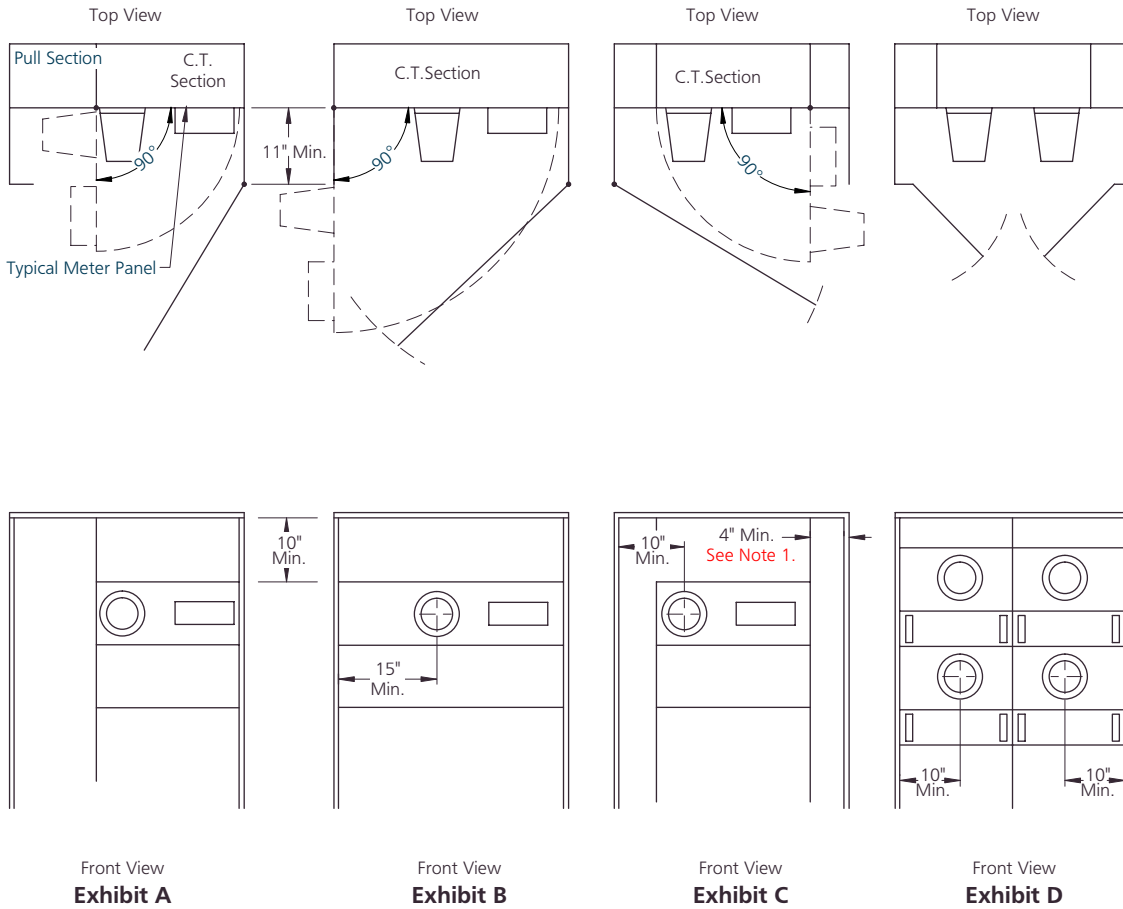

Notes

1. Hinged meter panels shall be capable of being opened 90 degrees with meter and test facilities in place, and provided the following clearances to any obstruction, 11 inches at the meter socket and 4 inches at the test-switch slotted opening. See Figure 6-12 (page 6-23) and Figure 6-17 (page 6-32) for hinged meter panels construction details.
2. Meter panels, either socket or blank, shall not be hinged to a hinged filler panel. Non-hinged filler panels shall not extend into the required instrument-transformer compartment access opening.
3. Enclosure doors providing access to utility compartments (i.e., metering sections and pull sections) shall be:
 - a. Equipped with a device to secure the doors in the open position at 90 degrees or more.
 - b. Secured in the closed position with a single, handle-operated, latching system. When provided with a locking means, each door, or set of doors, shall be equipped with an approved double-locking device, accepting padlocks with a 5/16 inch lockshaft, to allow access by both the Company and the customer.
4. The enclosure top, cover panels providing access to unmetrated bus, and internal equipment attached to the outer walls of the enclosure shall be secured in place with devices that may not be loosened from the outside. Screws or bolts requiring special tools for installation or removal are not acceptable. One way type screws are not acceptable.

ESR-6	Switchboards 600 Volts and Below	APPROVED <i>PhH</i>
PAGE 6-10	Electrical Service Requirements ► SCE Public ◀	EFFECTIVE DATE 1-11-2002

Figure 6-5: Overhead Service Termination Standard Switchboard Service Section 0-600 Volts

EUSER DRAWING NO. 348

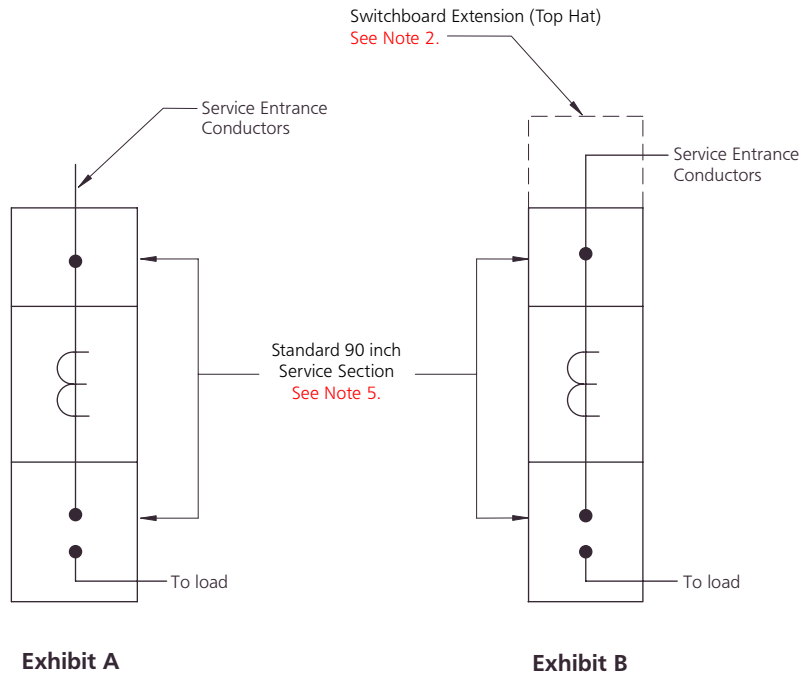

Notes

1. The service entrance conductors, Exhibit A or Exhibit B, either cable or bus bar, are furnished and installed by the customer in the following manner:
 - a. When switchboards are served through bus bar conductors, the conductors shall enter through the top, or at the side or back in the upper 10 inch section.
 - b. When switchboards are served through cable conductors, the conductors shall enter through the top of the board only, as shown in Exhibit A
2. When the Company or customer requires incoming conduits from the side or rear for the service conductors, an extension as shown in Exhibit B, or other special designed termination may be required. Consult the local Service Planning office for the extension dimension.
3. The direction of feed is from top to bottom in the standard switchboard service section. Load conductors shall leave below the metering compartment and may not be routed back through the current-transformer compartment in order to exit the service section.
4. Service entrance conductors shall be connected to the busing in the service section by the customer with lugs approved for the type conductors used.
5. For information on the standard 90 inch service section see [Figure 6-1 \(page 6-7\)](#) or [Figure 6-2 \(page 6-8\)](#).

APPROVED 	Switchboards 600 Volts and Below	ESR-6
EFFECTIVE DATE 1-11-2002	Electrical Service Requirements ▶ SCE Public ◀	PAGE 6-11

Figure 6-6: Underground Service Terminating Facilities in Pull Boxes or Pull Sections, 0-600 Volts

EUSER DRAWING NO. 347

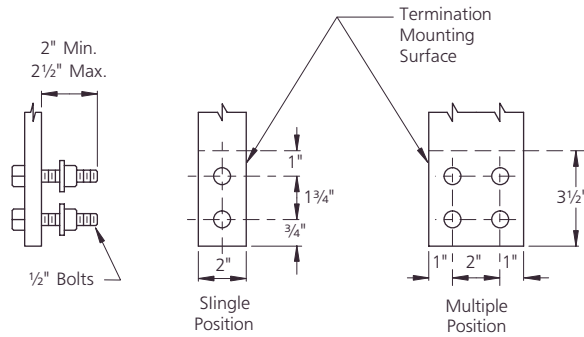

Exhibit A
Terminating Bolt and Drilling Detail of Terminating Facilities

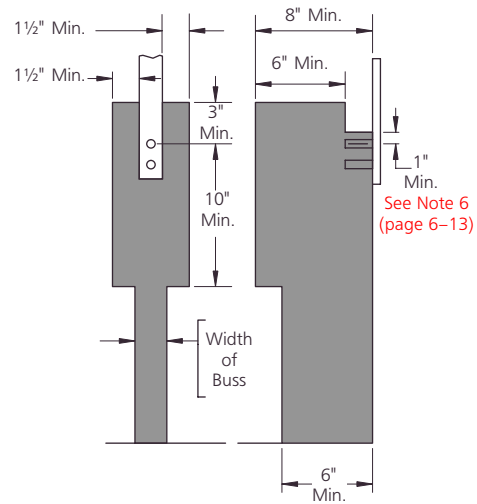

Exhibit D
Required unobstructed working space for all terminations

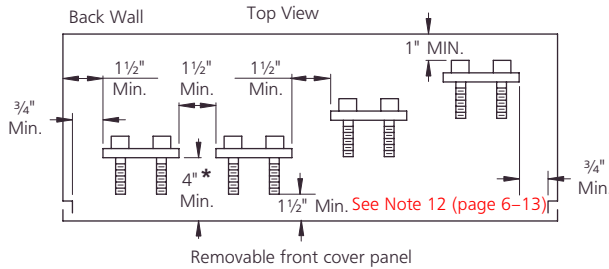

Exhibit B
Spacing requirements for terminating facilities (Side by side, or staggered)

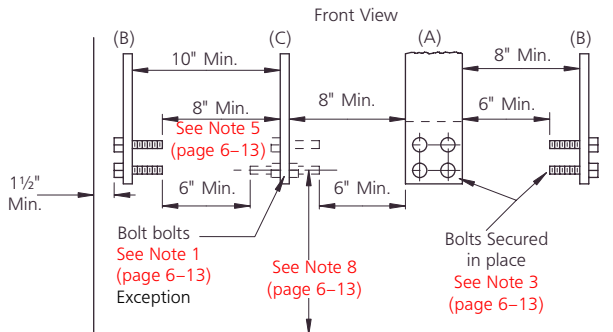

Exhibit C
Spacing requirements for terminating facilities accessible from (A) Front Only, (B) One Side Only, or (C) From Either Side
See Note 3. and Note 4 (page 6-13)

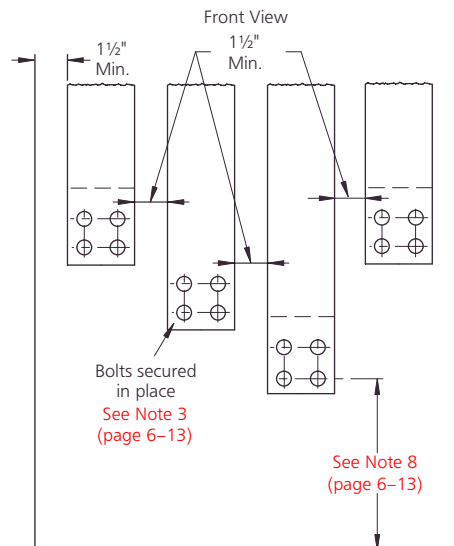

Exhibit E
Spacing requirements for top to bottom stagger of terminating facilities
*4 inch min. required.
Assures 1 inch min. clearance from body of terminating lug (when in place) to front panel.
Exception See Note 4. and Note 5 (page 6-13)

<p>ESR-6</p>	<p>Switchboards 600 Volts and Below</p>	<p>APPROVED <i>PhH</i></p>
<p>PAGE 6-12</p>	<p>Electrical Service Requirements ► SCE Public ◀</p>	<p>EFFECTIVE DATE 1-11-2002</p>

Notes

1. One landing position is required for each 400 amperes (or portion thereof) of service ampacity up to 1,200 amperes - consult local Service Planning office for services exceeding 1,200 amperes. Each landing position shall consist of two 1/2-inch steel bolts spaced on 1-3/4 inches vertical centers and extending from 2 inches to 2-1/2 inches maximum from the mounting surface. When multiple positions are required, provide a minimum of 2 inches of horizontal spacing between positions.
Exception: Edgewise terminating facilities may consist of 9/16-inch holes having the same spacing as specified for the 1/2-inch bolts as specified above and in "Exhibit A" (page 6-12). The unobstructed working space shall be provided on both sides of the termination bus, see "Exhibit C" (page 6-12).
2. Each terminating bolt shall be provided with a spring washer and a nut. The spring washer may be either a cone-type (belleville) washer or a split-ring washer and a flat washer. All parts shall be plated to prevent corrosion. Terminating bolts shall not be used to secure the termination bus in place.
3. Terminating bolts must be secured in place. "Secured in place" shall mean that the stud will not turn, back out, or loosen in any manner when tightening or loosening terminal nuts (including cross-threaded situations).
4. In the terminal mounting area, which is defined as the area of the terminating facilities shown in "Exhibit A" (page 6-12), a clear space (barrel of proximity) of 1-1/2 inches minimum is required around any terminating facility including its bolts and bolt heads, any other bus, any other terminating facility, or any grounded surface, except:
 - a. The minimum clearance to the back of the pull section may be reduced to 1 inch.
 - b. The minimum clearance to any fully insulated horizontal bus behind the terminating facility may be reduced to 1 inch.
 - c. The neutral terminating facility may have a minimum clearance of 1 inch from any grounded surface.
5. Each terminating facility shall have an unobstructed working space, accessible from the front of the pull section as viewed from the access compartment opening, in front of the entire mounting surface as shown in "Exhibit D" (page 6-12).
Exception: For terminating facilities with bolts facing the access opening as shown in "Exhibit B" (page 6-12), the required 1-1/2-inch side clearance (bus to access opening return flange) may be reduced to 3/4 inch.
6. The clearance directly above and measured from the center of the top termination bolt may be reduced to 1 inch to either an insulated surface or bus of the same potential.
7. No more than one termination facility may be mounted along any sidewall.
8. See Figure 3-7 (page 3-26) through Figure 3-9 (page 3-29) and Figure 6-7 (page 6-14) for the minimum distance from the lowest bolt on the termination facility to the bottom of the termination enclosure.
9. Terminating facilities shall be secured to prevent turning or bus misalignment when the cables are installed.
10. The neutral terminating facility shall be permanently identified in clearly visible block lettering reading either "neutral" or "N".
11. Uninsulated buses of different potentials shall not be permitted below or behind any terminating position as viewed from the front of the pull section. If cross-busing is installed below or behind a terminating position, the cross-busing shall be fully insulated or barriered.
12. For switchboard pull sections, a 1-1/2 inch minimum dimension is permitted from any energized part to a removable access cover panel when a safety barrier is provided by the manufacturer. Where a safety barrier is not provided, the minimum clearance shall be increased to 4 inches. The safety barrier shall:
 - a. Be constructed of a rigid insulating material, resistant to damage by impact or puncture, with a minimum thickness of 1/8 inch.
 - b. Extend a minimum of 10 inches below terminating bus and extend upward to cover all energized parts that infringe into the 4 inch minimum clearance dimension, and be removable.^{1/}
 - c. Have a caution sign affixed to the barrier reading "**WARNING: THIS BARRIER MUST BE INSTALLED BEFORE REPLACING PULL SECTION COVERS**". Additional caution signs shall be affixed to exterior of each pull section access cover reading "**DO NOT REPLACE PULL SECTION COVERS UNTIL SAFETY BARRIER IS IN PLACE**".

1/ Brackets and associated hardware used to mount the safety barrier shall not extend into the provided access opening.

APPROVED 	Switchboards 600 Volts and Below	ESR-6
EFFECTIVE DATE 1-11-2002	Electrical Service Requirements ▶ SCE Public ◀	PAGE 6-13

Figure 6-7: Underground Service Termination Standard Switchboard Service Section 400 to 4000 Amp, 0-600 Volts

EUSER DRAWING NO. 345

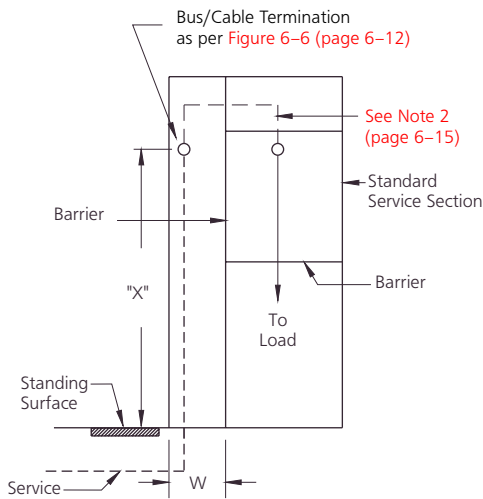

Exhibit A
Switchboard Pull Section

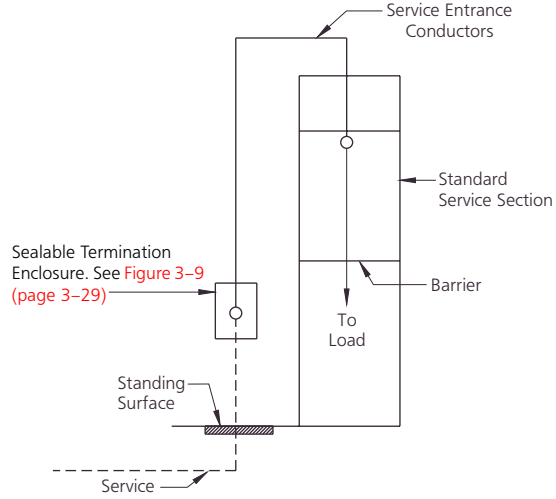

Exhibit B
Separate Termination Enclosure

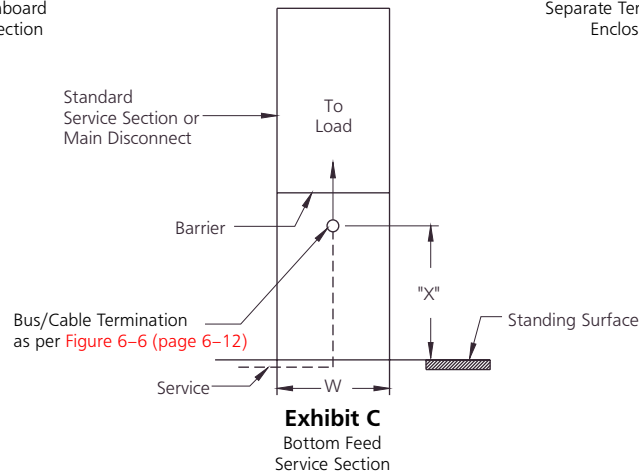

Exhibit C
Bottom Feed Service Section

(See Figure 6-3 (page 6-9) for construction requirements, see Note 11 (page 6-15))

Table 6-1: Minimum Pull Section Dimensions. See Note 6 (page 6-15)

Switchboard Rating (Amperes)	Minimum Access Opening Dimension (W) See Note 5 (page 6-15)		Minimum Termination Height (X)
	Three-Wire (in)	Four-Wire (in)	
400-800	24 ^(a)	24	42 ^(b) Min. - 72" Max.
801-1200	—	30	
1201-2000	—	35	
2001-3000	—	42	60" Min. - 72" Max.
3001-4000	—	44	60" Min. - 72" Max.

(a) For single-phase, three wire only, 600 amperes maximum.

(b) For reduced termination height in bottom-feed service sections, see Figure 6-3 (page 6-9)

ESR-6	Switchboards 600 Volts and Below	APPROVED <i>PhH</i>
PAGE 6-14	Electrical Service Requirements ▶ SCE Public ◀	EFFECTIVE DATE 1-11-2002

Notes

1. A switchboard pull section as shown in "Exhibit A" (page 6-14), a separate (nonattached) termination enclosure as shown in "Exhibit B" (page 6-14), or a combination switchboard service section and pull section (bottom feed) as shown in "Exhibit C" (page 6-14) shall be provided for underground services.
2. Bus bars or cables shall extend from the pull section into switchboard service sections rated up to 800 amperes. Bus bars are required when the service section rating exceeds 800 amperes or multiple metering is supplied. **In either case the company will terminate its service conductors in the pull section.**
3. When the service section is supplied from a switchboard pull section as shown in "Exhibit A" (page 6-14), the bus bars or cables shall enter through the side or back of the sealable section above the current-transformer compartment, or by means of horizontal cross-busing in back of the metering compartment.
4. When the service section is supplied from a switchboard pull section below the terminating facilities, the lowest cross buss unit and the transition bussing supplying the cross bus units shall not be less than two feet above the bottom of the enclosure or more than 8 inches from the back of the enclosure.
5. The minimum pull section access opening (W) is measured between the left side and right side return flanges.
6. Side or rear entry of service entrance cables into the pull section may require greater dimensions than shown in Table 6-1 (page 6-14). Consult the local Service Planning office for requirements.
7. All terminating enclosures (i.e., pull boxes and pull sections) shall have full front access. Cover panels shall be removable, sealable, provided with two lifting handles, and limited to a maximum of 9 square feet in area.
8. Sealing provisions shall consist of two drilled stud and wing-nut assemblies on opposite sides of the panels.
9. See Figure 6-6 (page 6-12) for construction details and clearance requirements for terminating facilities in pull boxes and pull sections.
10. Ground bus, when provided shall be located at the rear of the terminating enclosure.
11. Bottom feed service sections of main disconnects are limited to a maximum of 2000 amperes.
12. The Company will furnish and install the terminating lugs for their service cables. Consult the local Service Planning office for the number of landing positions required.
13. For the number of service conduits in a pull section for the main switch ultimate capacity, see Table 6-2.

Table 6-2: Number of Service Conduits for Commercial/Industrial Underground Pull Sections

Main Switch Ultimate Capacity	Number of Conduits
400 amps	1-4"
600 amps/800 amps	2-4"
1,000 amps	4-4" (See Note 4)
1,200 amps	4-4"
1,600 amps	6-4"
2,000 amps/2,500 amps	2 banks of 4-4" (See Note 3)
3,000 amps	2 banks of 6-4" (See Note 3)
4,000 amps	Cable Trench (See Note 5)

NOTES:

1. The recommended number of conduits is based on ultimate ampacities of cable at 75 percent load factor.
2. When service conduit extend beyond 100 feet, consult the Company for conduit size requirements.
3. Cable trench is preferred. When two conduit banks are used, they shall be spaced a minimum of six feet apart, until conduit is configured to pull section.
4. 3-4-inch conduits may be used, but 4-4-inch conduits create a block for semi-encasement.
5. Cable trench is preferred. When it is not practical to install cable trench, two banks of 7-4-inch conduits may be used, and they shall be placed a minimum of six feet apart.

APPROVED 	Switchboards 600 Volts and Below	ESR-6
EFFECTIVE DATE 1-11-2002	Electrical Service Requirements ▶ SCE Public ◀	PAGE 6-15

Figure 6-8: Instrument-Transformer Compartment for Switchboards 0-1,000 Amps Maximum, 0-600 Volts Single- or Three- Phase Three-Wire

EUSER DRAWING NO. 319

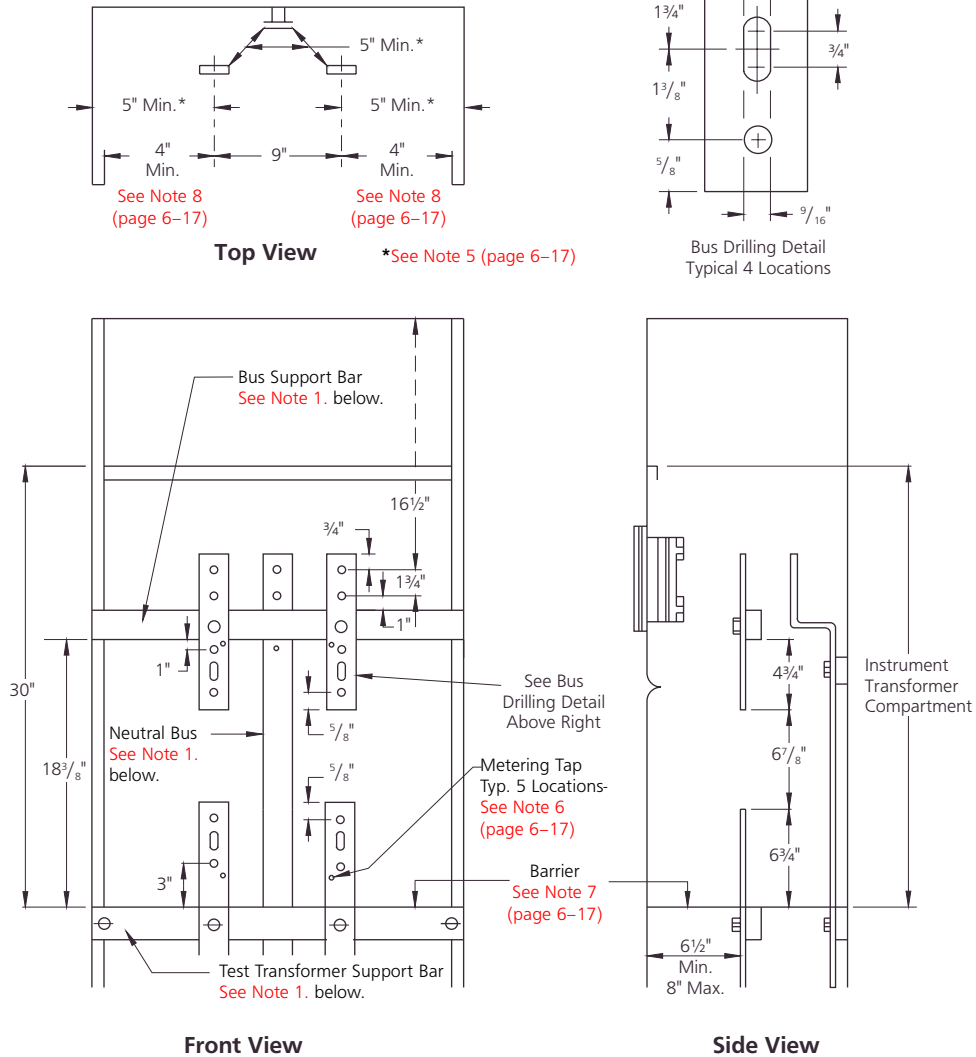

Notes

1. Bus arrangement and supports shall be provided as shown, except the neutral bus may be located at either side or on either side wall. Bus supports shall be constructed of a continuous bar of insulating material and shall be rigid to prevent misalignment of the bus units with the cables in place.
2. The bus units may be supplied from the top or bottom, and shall be anchored to prevent turning. Bus units shall be constructed of rectangular bus and when laminated shall have no space between laminations. Bus dimensions shall be provided as follows:

Minimum:	1/4 inch x 2 inches
Maximum:	3/4 inch x 2 inches

ESR-6	Switchboards 600 Volts and Below	APPROVED <i>PhH</i>
PAGE 6-16	Electrical Service Requirements ► SCE Public ◀	EFFECTIVE DATE 1-11-2002

3. When the compartment is supplied from horizontal cross-busing, the busing shall pass through the compartment or in the sealed area above the compartment.
4. Except for conductors supplying the instrument-transformer compartment, no other conductors or devices shall be installed in, or routed through, the compartment or the sealed area above the compartment.
5. A clear unobstructed work space shall be provided around the current-transformer bus units from the barrier to the upper support bar.
6. Taps for attachment of meter wiring shall be provided as follows:
 - a. One tap on each upper and lower phase bus unit with a 10-32 screw and washer provided for each phase bus in either the upper or lower position.
 - b. One tap on the neutral bus as shown, or when the compartment is supplied from cross-busing a tap may be provided on the neutral cross-bus, or on a bus bar extension provided from the neutral cross-bus. A 10-32 screw and washer shall be provided for the neutral bus. Tap locations shall be centered between phase bus units, or at either side, and shall be readily accessible under energized conditions and with the current-transformers in place.
7. The barrier shall be constructed of a rigid insulating material resistant to ARC tracking, and shall be secured in place with a maximum deflection of 1/2 inch from an applied force of 25 pounds downward. Openings in the barrier (i.e., peripheral gaps around barrier, cutouts around bus bars, and hole diameters provided for ventilation) shall not exceed 3/8 inch. The barrier shall be attached with nonconductive fasteners.
8. Dimension measured to inside edge of the compartment access opening.
9. Compartment shall be on the supply side of the main disconnect.
10. Single phase service is limited to 400 or 600 amperes maximum. Consult the local Service Planning office for details.

APPROVED 	Switchboards 600 Volts and Below	ESR-6
EFFECTIVE DATE 1-11-2002	Electrical Service Requirements ▶ SCE Public ◀	PAGE 6-17

Figure 6-9: Instrument-Transformer Compartment for Switchboards 0-1000 Amperes, 0-600 Volts Three Phase Four-Wire

EUSER DRAWING NO. 320

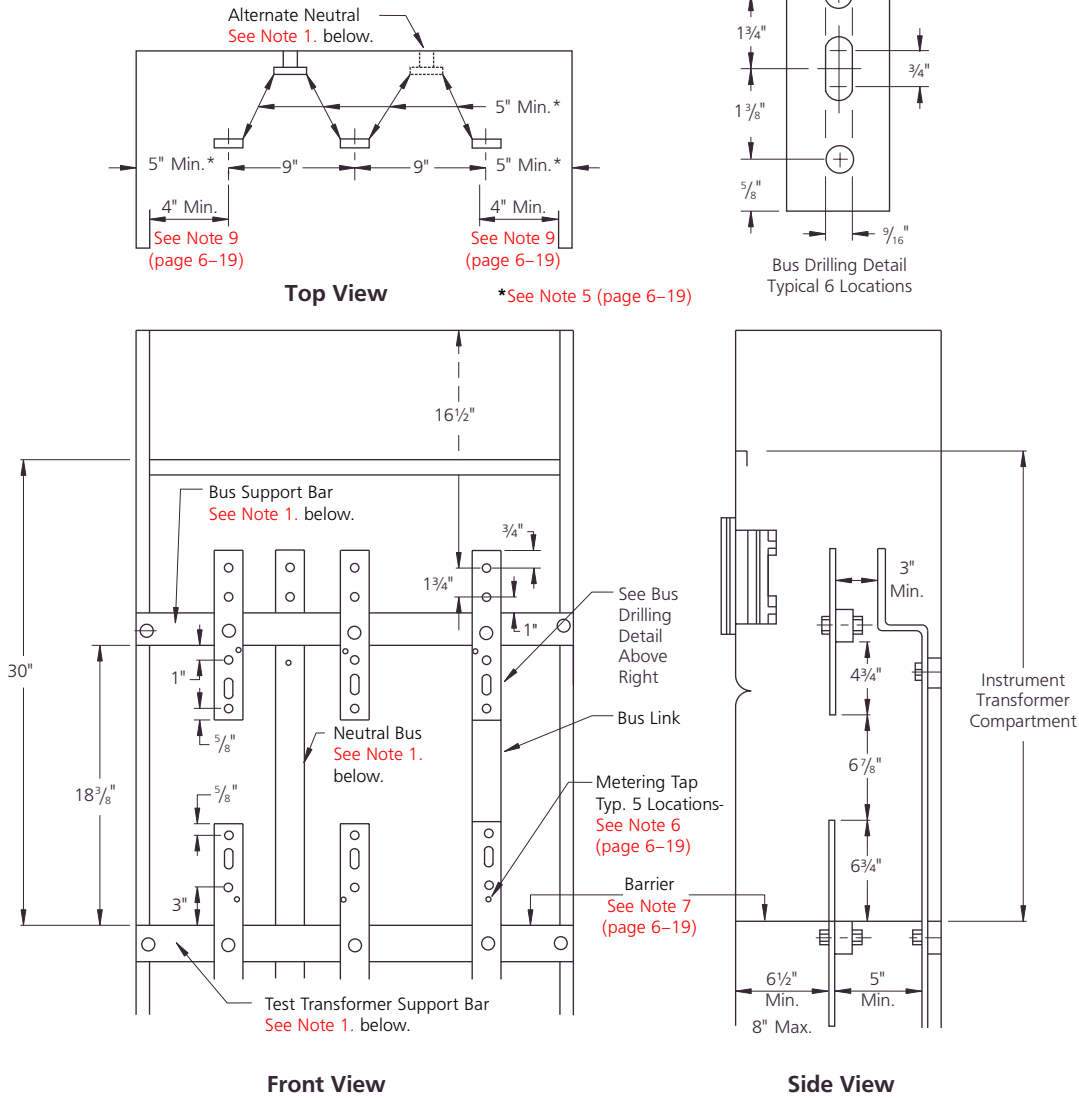

Notes

1. Bus arrangements and supports shall be provided as shown, except the neutral bus may be located at either side or on either side wall. Bus supports shall be constructed of a continuous bar of insulating material and shall be rigid to prevent misalignment of the bus units with the cables in place.
2. The bus units may be supplied from the top or bottom and shall be anchored to prevent turning. Bus units shall be constructed of rectangular bus and when laminated shall have no space between laminations. Bus dimensions shall be provided as follows:

Minimum:	1/4 inch x 2 inches
Maximum:	3/4 inch x 2 inches

ESR-6	Switchboards 600 Volts and Below	APPROVED <i>PhH</i>
PAGE 6-18	Electrical Service Requirements ▶ SCE Public ◀	EFFECTIVE DATE 1-11-2002

3. When the compartment is supplied from horizontal cross-busing, the busing shall pass through the compartment or in the sealed area above the compartment.
4. Except for conductors supplying the instrument-transformer compartment, no other conductors or devices shall be installed in, or routed through, the compartment or the sealed area above the compartment.
5. A clear unobstructed work space shall be provided around the current-transformer bus units from the barrier to the upper support bar.
6. Taps for attachment of meter wiring shall be provided as follows:
 - a. One tap on each upper and lower phase bus unit with a 10-32 screw and washer provided for each phase bus in either the upper or lower position.
 - b. One tap on the neutral bus as shown, or when the compartment is supplied from cross-busing a tap may be provided on the neutral cross-bus, or on a bus bar extension provided from the neutral cross-bus. A 10-32 screw and washer shall be provided for the neutral bus. Tap locations shall be centered between phase bus units, or at either side, and shall be readily accessible under energized conditions and with current-transformers in place.
7. The barrier shall be constructed of a rigid insulating material resistant to ARC tracking, and shall be secured in place with a maximum deflection of 1/2 inch from an applied force of 25 pounds downward. Openings in the barrier (i.e., peripheral gaps around barrier, cutouts around bus bars, and hole diameters provided for ventilation) shall not exceed 3/8 inch. The barrier shall be attached with nonconductive fasteners.
8. The power leg bus for a four-wire delta service shall be identified by an orange-colored outer finish, or by tagging or other effective means.
9. Dimension measured to inside edge of the compartment access opening.
10. Compartment shall be on the supply side of the main disconnect.

APPROVED 	Switchboards 600 Volts and Below	ESR-6
EFFECTIVE DATE 1-11-2002	Electrical Service Requirements ▶ SCE Public ◀	PAGE 6-19

Figure 6-10: Instrument-Transformer Compartment for Switchboards 1001-3000 Amperes, 0-600 Volts Three Phase Four-Wire

EUSER DRAWING NO. 322

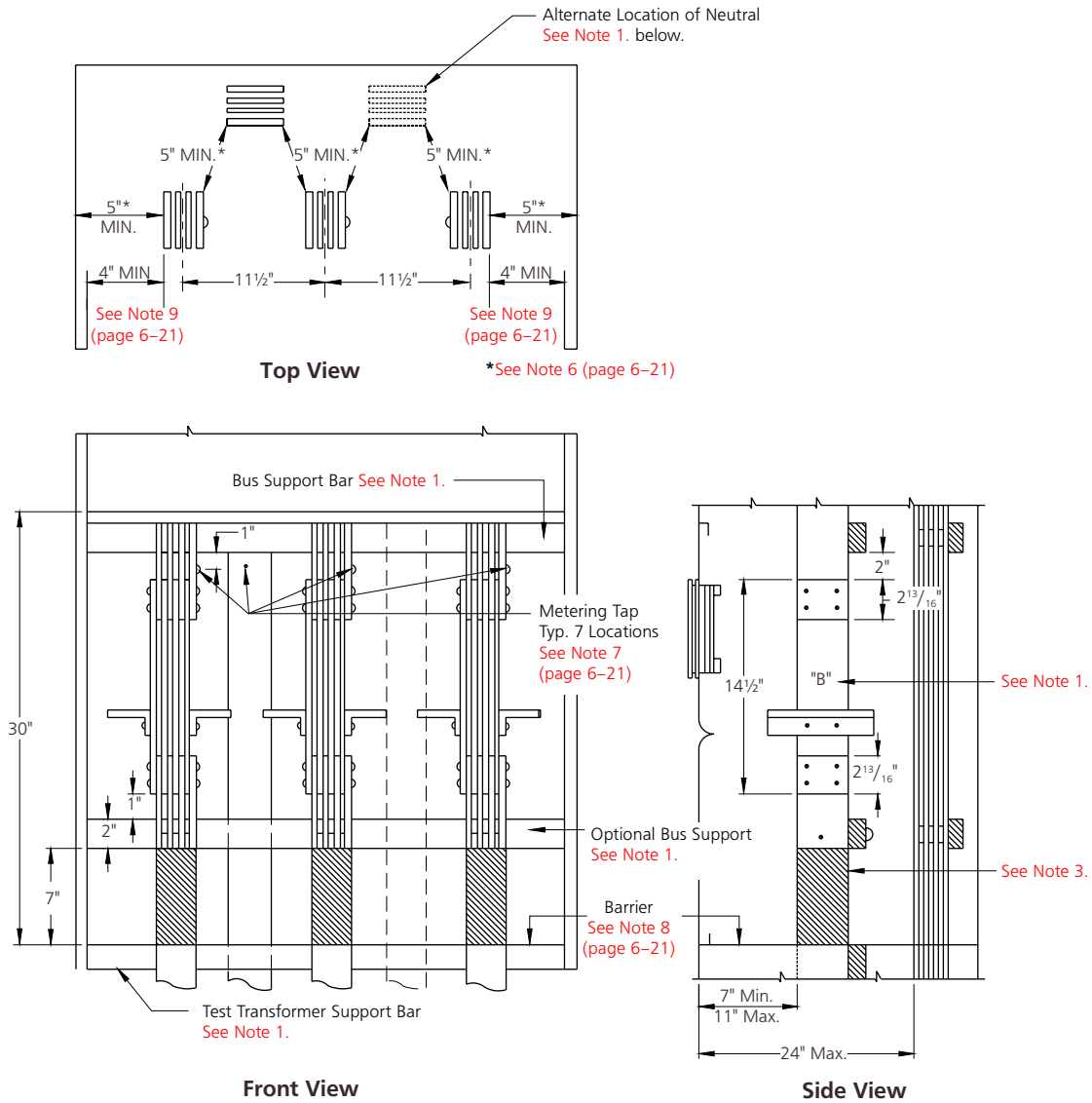

Notes

1. Bus arrangements and supports shall be provided as shown, except the neutral bus may be located at either side or on either side wall. Bus units shall be anchored so that buses will remain in position when section "B" is removed. For details of section "B" and the insulated current-transformer support, see Figure 6-11 (page 6-22). Bus supports shall be constructed of a continuous bar of insulating material.
2. The bus units may be supplied from the top or bottom, and shall be constructed of rectangular bus. Maximum allowable bus size shall be four 1/4 inch x 4 inch bars spaced 1/4 inch
3. Bus units shall be insulated as shown and the insulating material shall be rated for the serving voltage. Round bus corners as necessary to prevent damage to insulation.

ESR-6	Switchboards 600 Volts and Below	APPROVED <i>PhH</i>
PAGE 6-20	Electrical Service Requirements ▶ SCE Public ◀	EFFECTIVE DATE 1-11-2002

4. When the compartment is supplied from horizontal cross-busing, the busing shall pass through the compartment or in the sealed area above the compartment.
5. Except for bus supplying the instrument-transformer compartment, no other conductors or devices shall be installed in, or routed through, the compartment or the sealed area above the compartment.
6. A clear unobstructed work space shall be provided around the current-transformer bus units from the barrier to 2 inches above the removable current-transformer bus sections ("B").
7. A 10-32 tap for attachment of meter wiring shall be provided as follows:
 - a. One tap on each upper and lower phase bus unit with a 10-32 screw and washer provided for each phase bus in either the upper or lower position.
 - b. One tap on the neutral bus as shown, or when the compartment is supplied from cross-busing a tap may be provided on the neutral cross-bus, or on a bus bar extension provided from the neutral cross-bus. A 10-32 screw and washer shall be provided for the neutral bus. Tap locations shall be centered between phase bus units, or at either side, and shall be readily accessible under energized conditions and with the current-transformers in place.
8. The barrier shall be constructed of a rigid insulating material resistant to ARC tracking and shall be secured in place with a maximum deflection of 1/2 inch from an applied force of 25 pounds downward. Openings in the barrier (i.e., peripheral gaps around barrier, cutouts around bus bars, and hole diameters provided for ventilation) shall not exceed 3/8 inch. The barrier shall be attached with non-conductive fasteners.
9. Dimension measured to inside edge of the compartment access opening.
10. For underground services installed by the Company the buses shall extend into the pull section, see [Figure 6-7 \(page 6-14\)](#).
11. On four-wire delta services, the power leg bus shall be identified by an "orange-color" outer finish or by tagging or by other effective means.
12. Compartment shall be on the supply side of the main disconnect.

APPROVED 	Switchboards 600 Volts and Below	ESR-6
EFFECTIVE DATE 1-11-2002	Electrical Service Requirements ▶ SCE Public ◀	PAGE 6-21

Figure 6-11: Removable Link and Current-Transformer Support for Instrument-Transformer Compartments with 4-inch Bus 0-600 Volts

EUSER DRAWING NO. 330

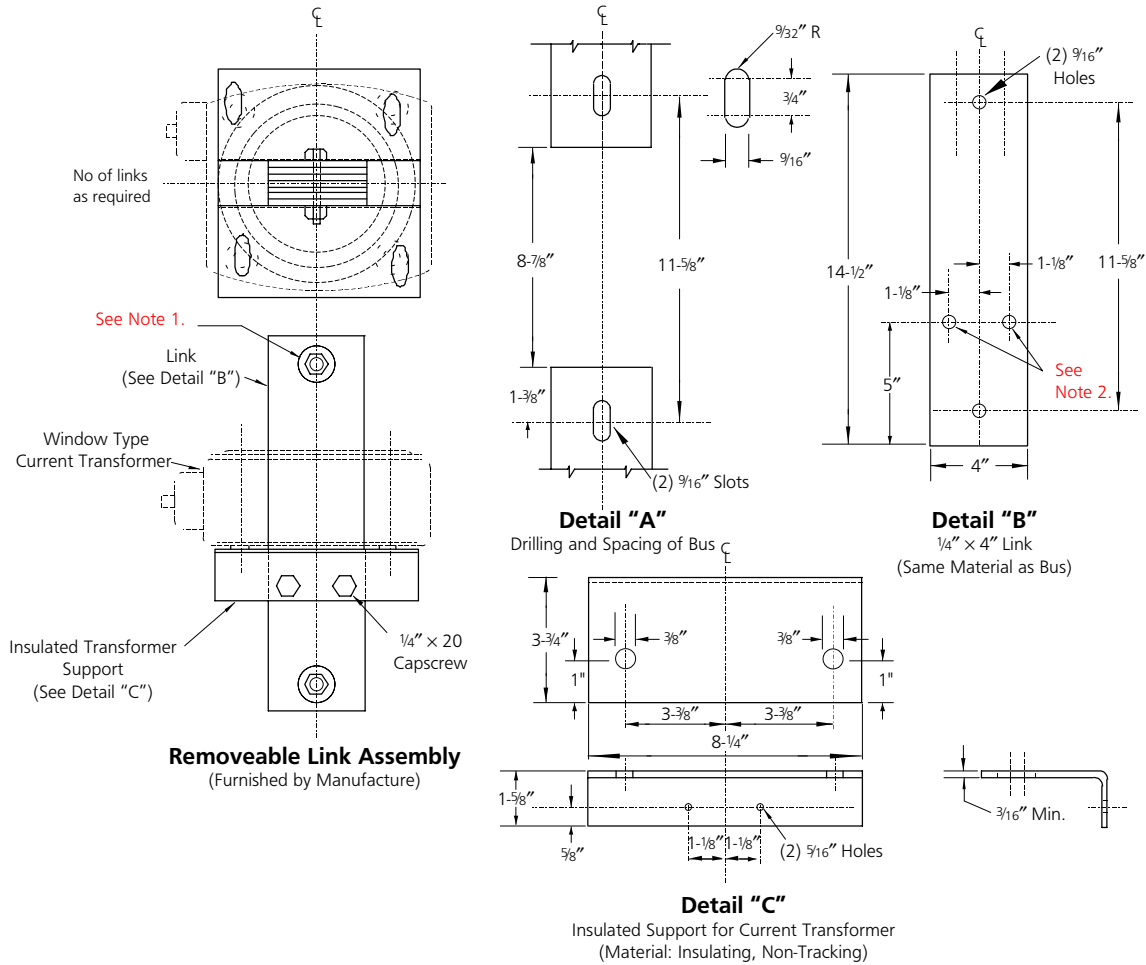

Notes

1. The manufacturer shall secure the removable bus link to the upper and lower current-transformer bus units using 1/2 inch hex-head (grade 5) steel bolts with associated washers and nuts. Each bolt shall be provided with a flat washer, a spring washer and a nut. Spring washers may be either a cone-type (belleville) washer or a split-ring washer with a flat washer. All washers (belleville or flat) shall be 2-1/4 inches minimum diameter.
2. Drill and tap two holes as shown on the outer bus units for 1/4 inch x 20 capscrews.

<p>ESR-6</p>	<p>Switchboards 600 Volts and Below</p>	<p>APPROVED <i>PhH</i></p>
<p>PAGE 6-22</p>	<p>Electrical Service Requirements ▶ SCE Public ◀</p>	<p>EFFECTIVE DATE 1-11-2002</p>

Figure 6-12: 15-Inch Hinged Meter Panel 0-600 Volts

EUSER DRAWING NO. 332

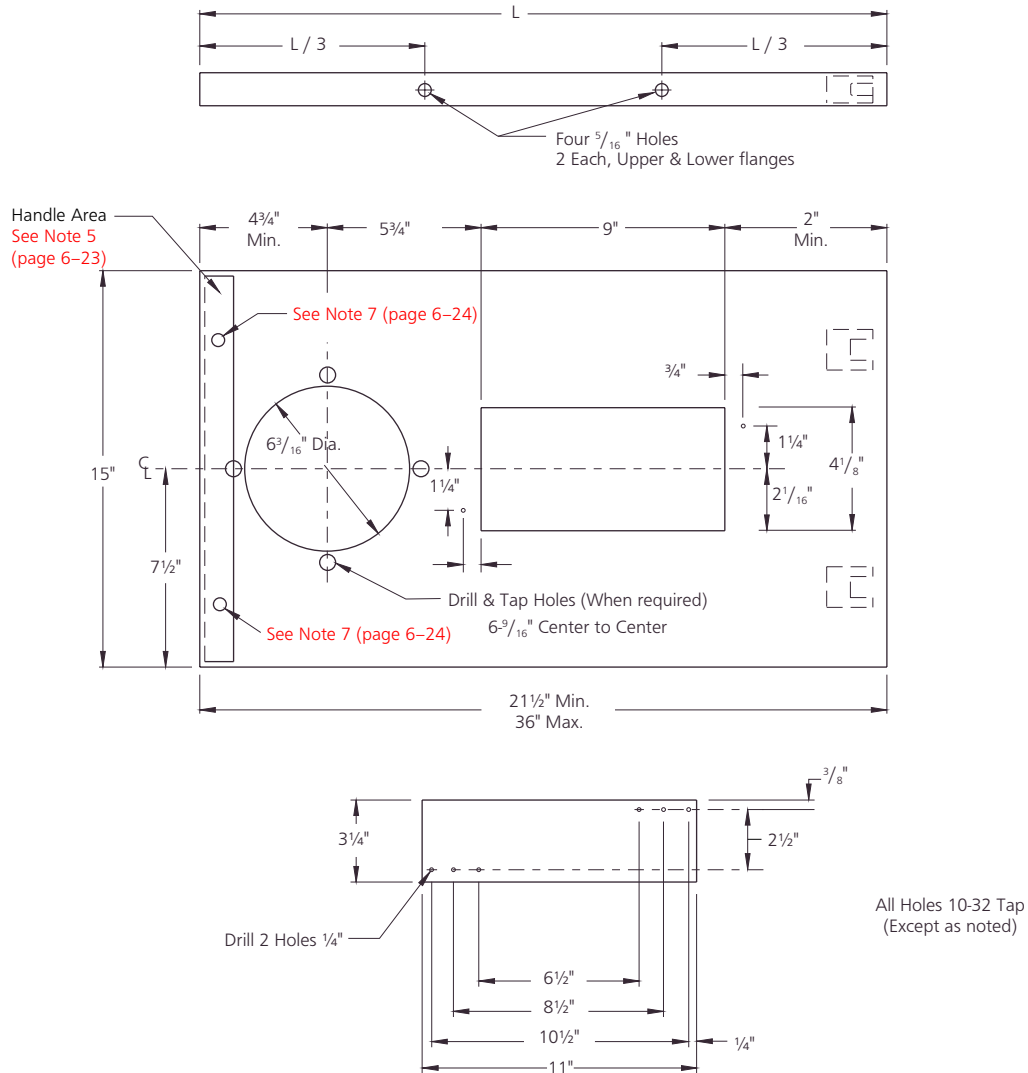

Test Switch Mounting Plate

Notes

1. The panel shall be constructed of 12 gauge (minimum) steel and furnished with a meter socket, sealing ring, and a slotted opening and removable plate for the installation of a secondary test switch. The slotted opening and removable plate edges shall be smooth to prevent damage to meter wiring.
2. The removable plate shall be attached to the rear of the panel with screws that do not protrude through the face of the panel.
3. The meter socket shall be designed for back connection.
4. The panel shall be equipped with hinges. The hinges shall permit the panel to open to 90 degrees, and shall be readily interchangeable, right or left, on the meter socket panel. For clevis or removable pin type hinges, the pin shall be removable from the top.
5. The panel shall be equipped with a handle on the unsupported end. The handle shall be interchangeable, right or left, on the meter socket panel and maintain a 1 inch (minimum) clearance from the meter socket flange and slotted opening.

APPROVED 	Switchboards 600 Volts and Below	ESR-6
EFFECTIVE DATE 1-11-2002	Electrical Service Requirements ▶ SCE Public ◀	PAGE 6-23

6. The panel shall support a 25-pound load applied at the unsupported end when fully opened with a maximum sag of 1/8 inch.
7. All securing screws and sealing screws shall be captive. Stud and wing-nut assemblies shall be sealable.
8. See [ESR-5: Table 5-3](#) and [ESR-5: Figure 5-2](#) for meter socket terminal arrangements.

ESR-6	Switchboards 600 Volts and Below	APPROVED <i>PhH</i>
PAGE 6-24	Electrical Service Requirements ▶ SCE Public ◀	EFFECTIVE DATE 1-11-2002

Figure 6-13: Instrument-Transformer Compartment for Switchboards 3001-4000 Amperes, 0-600 Volts Three Phase Four-Wire

EUSER DRAWING NO. 324

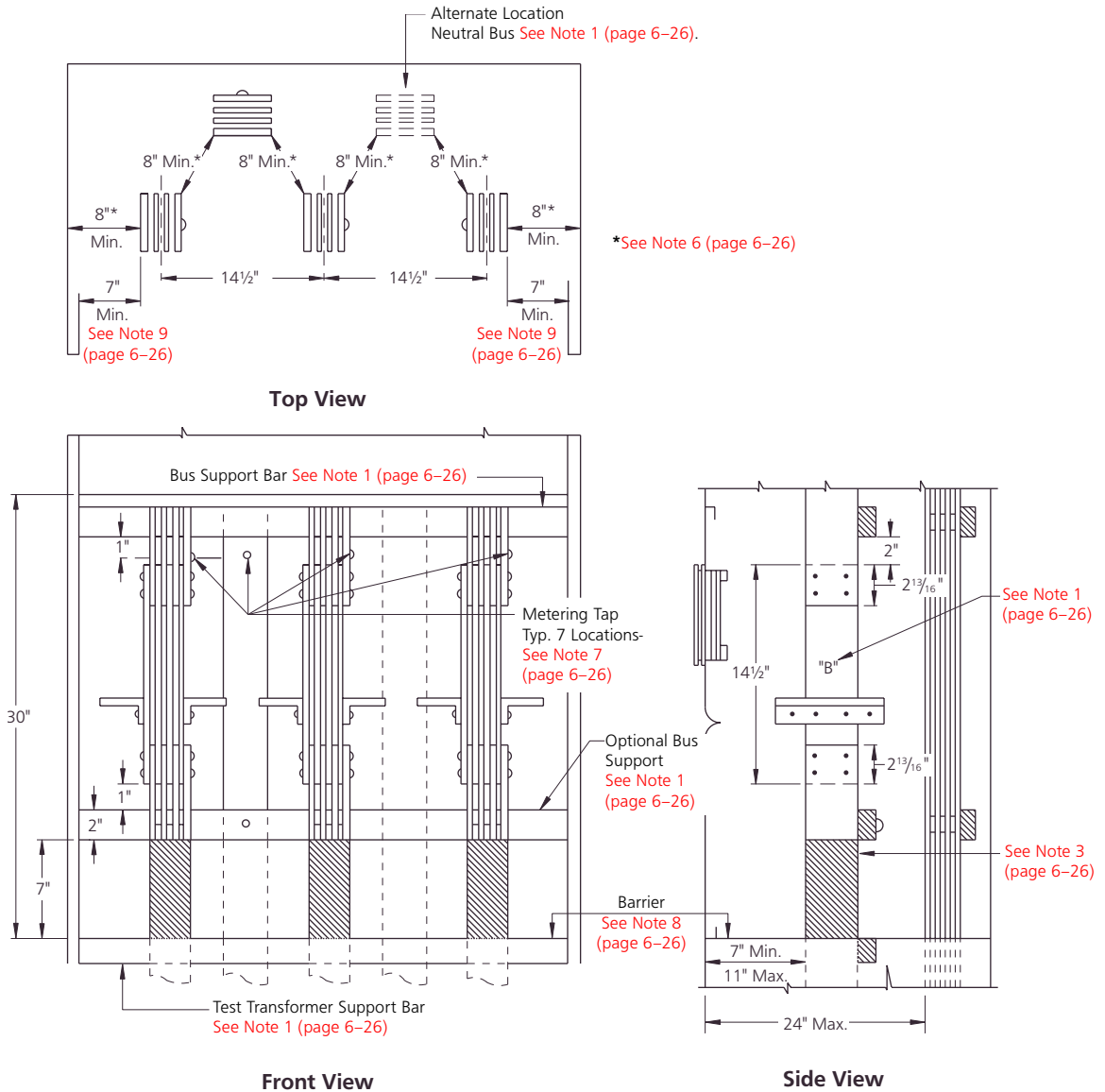

Table 6-3: Maximum Allowable Bus Size

Four-1/4 inch x 4 inch bars spaced 1/4 inch
Six-1/4 inch x 5 inch bars spaced 1/4 inch
Five-3/8 inch x 5 inch bars spaced 3/8 inch

APPROVED <i>Ph.H</i>	Switchboards 600 Volts and Below	ESR-6
EFFECTIVE DATE 1-11-2002	Electrical Service Requirements ► SCE Public ◀	PAGE 6-25

Notes

1. Bus arrangements and supports shall be provided as shown, except the neutral bus may be located at either side or on either side wall. Bus units shall be anchored so that buses will remain in position when section "B" is removed. For details of section "B" and the insulated current-transformer support, see [Figure 6-11 \(page 6-22\)](#) for 4 inch bus and [Figure 6-14 \(page 6-27\)](#) for 5 inch bus. Consult the Company for the use of bus larger than 5 inches. Bus supports shall be constructed of a continuous bar of insulating material.
2. The bus units may be supplied from the top or bottom, and shall be constructed of rectangular bus. For maximum allowable bus sizes, see [Table 6-3 \(page 6-25\)](#).
3. Bus units shall be insulated as shown and the insulating material shall be rated for the serving voltage. Round bus corners as necessary to prevent damage to insulation.
4. When the compartment is supplied from horizontal cross-busing, the busing shall pass through the compartment or in the sealed area above the compartment.
5. Except for bus supplying the instrument-transformer compartment, no other conductors or devices shall be installed in, or routed through, the compartment or the sealed area above the compartment.
6. A clear unobstructed work space shall be provided around the current-transformer bus units from the barrier to 2 inches above the removable current-transformer bus sections ("B").
7. A 10-32 tap for attachment of meter wiring shall be provided as follows:
 - a. One tap on each upper and lower phase bus unit with a 10-32 screw and washer provided for each phase bus in either the upper or lower position.
 - b. One tap on the neutral bus as shown, or when the compartment is supplied from cross-busing a tap may be provided on the neutral cross-bus, or on a bus bar extension provided from the neutral cross-bus. A 10-32 screw and washer shall be provided for the neutral bus. Tap locations shall be centered between phase bus units, or at either side, and shall be readily accessible under energized conditions and with the current-transformers in place.
8. The barrier shall be constructed of a rigid insulating material resistant to ARC tracking and shall be secured in place with a maximum deflection of 1/2 inch from an applied force of 25 pounds downward. Openings in the barrier (i.e., peripheral gaps around barrier, cutouts around bus bars, and hole diameters provided for ventilation) shall not exceed 3/8 inch. The barrier shall be attached with nonconductive fasteners.
9. Dimension measured to inside edge of the compartment access opening.
10. For underground service installed by the Company the buses shall extend into the pull section, see [Figure 6-7 \(page 6-14\)](#).
11. Compartment shall be on the supply side of the main disconnect.

ESR-6	Switchboards 600 Volts and Below	APPROVED 
PAGE 6-26	Electrical Service Requirements ▶ SCE Public ◀	EFFECTIVE DATE 1-11-2002

Figure 6-14: Removable Link and Current-Transformer Support for Instrument-Transformer Compartments with 5-inch Bus 0-600 Volts

EUSER DRAWING NO. 331

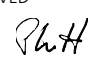
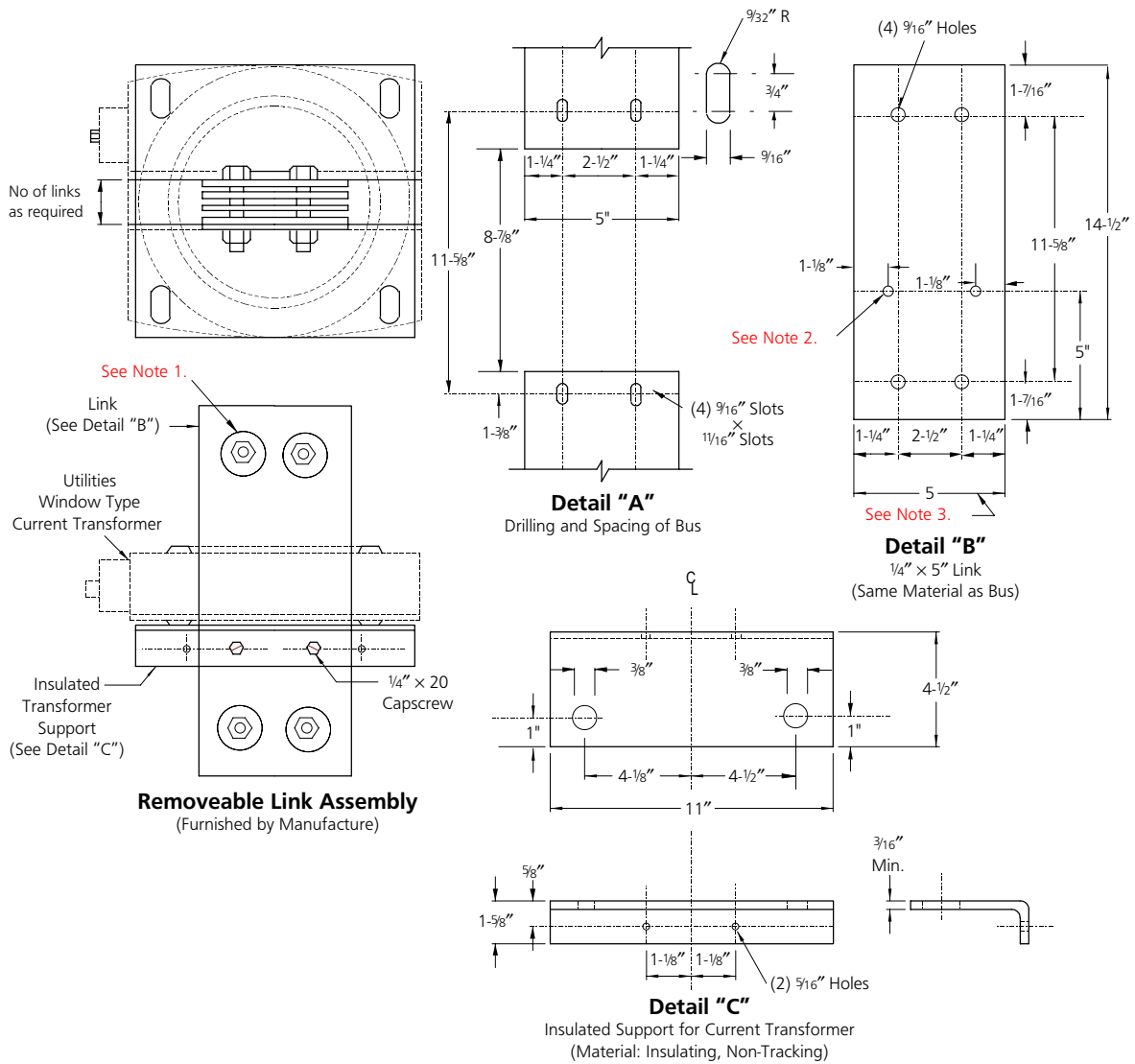

Notes

1. The manufacturer shall secure the removable bus link to the upper and lower current-transformer bus units using 1/2 inch hex-head (grade 5) steel bolts with associated washers and nuts. Each bolt shall be provided with a flat washer, a spring washer and a nut. Spring washers may be either a cone-type (belleville) washer or a split-ring washer with a flat washer. All washers (belleville or flat) shall be 2-1/4 inches minimum diameter.
2. Drill and tap two holes as shown on the outer bus units for 1/4 inch x 20 capscrows.
3. Consult the Company for use of bus bars larger than 5 inches.

APPROVED <i>Ph.H</i>	Switchboards 600 Volts and Below	ESR-6
EFFECTIVE DATE 1-11-2002	Electrical Service Requirements ► SCE Public ◀	PAGE 6-27

Figure 6-15: Self-Contained Meters Installed in Switchboards 0-200 Amps 0-600 Volts

EUSER DRAWING NO. 306

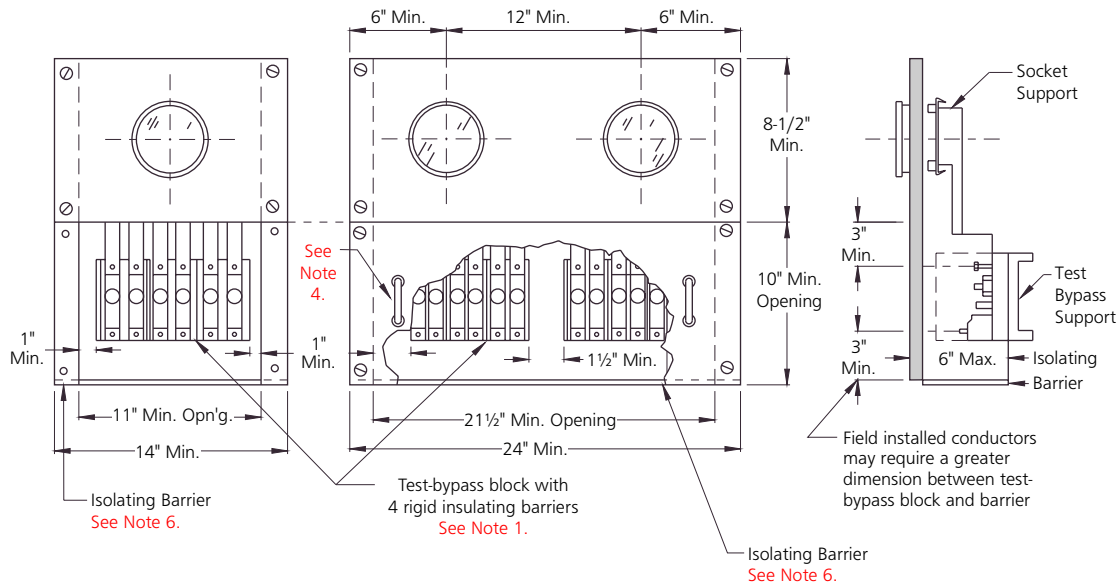

Notes

1. Test-bypass blocks with rigid insulating barriers shall be furnished, installed, and wired or bused to the meter socket by the manufacturer. Connection sequence is line-load from left to right.
2. Metered conductors shall not pass through adjacent metering compartments except in enclosed wireways. To insure proper identification of cables in factory cabled equipment, metered cables (except in the test-bypass area), shall be either physically barriered or bundled so as to separate them from unmetered cable or permanently marked and isolated from unmetered cables. Physical barriers will not be required if the unmetered conductors are bus.
3. Meter panels shall be removable with a maximum of two meters per panel. Meter panels shall be provided with a sealing ring for each meter socket and each meter socket shall be rigidly mounted on a support and attached to the meter panel. See ESR-5: Table 5-3 and ESR-5: Figure 5-2 for meter socket terminal requirements.
4. Test-bypass block cover panel shall be sealable and fitted with a lifting handle. All panels exceeding 16 inches in width shall require two lifting handles.
5. When a neutral is required for metering or testing, an insulated neutral terminal shall be provided behind each test-bypass cover panel. The terminal shall be readily accessible when the cover panel is removed and shall be individually connected to the neutral bus with a minimum size No. 8 AWG copper wire.
6. A factory-installed, full-width insulating barrier shall be located at the bottom of each test-bypass compartment. In addition, a full width and depth isolating barrier shall be located below the bottom test-bypass compartments and above the load terminals of the meter disconnect devices. If a factory-installed rear load wireway is provided, the isolating barrier shall extend back to that wireway. Ventilation openings, when provided, shall not exceed a maximum diameter of 3/8 inch. A slot in the isolating barrier provided for the load conductors supplied from the test-bypass blocks shall be a maximum of 1-1/2 inches in depth and may extend to the width of the meter disconnect devices. The slot may not be located in the front 6 inches of the test-bypass compartment insulating barrier.
7. For three-phase, four-wire, connect 7th jaw of meter socket to body of neutral lug with a white No. 12 AWG copper wire.
8. For three-phase, four-wire delta, identify right hand test-bypass block (2 poles) as power leg. Identification to be orange in color.
9. For three-phase three-wire, install bus to connect line and load poles together at top of center test-bypass block and connect 5th jaw of meter socket to this bus using minimum No. 12 AWG copper wire. Color used to identify the wire shall not be white, grey, green or orange.
10. For single phase, three-wire, omit center test-bypass block.

ESR-6	Switchboards 600 Volts and Below	APPROVED <i>PhH</i>
PAGE 6-28	Electrical Service Requirements ► SCE Public ◀	EFFECTIVE DATE 1-11-2002



11. For single phase, three-wire, 120/208 volts, omit center test-bypass block and connect 5th jaw of meter socket to body of neutral lug with white No. 12 AWG copper wire.
12. Separate line and load conductors shall be installed by the contractor or manufacturer for each meter socket.
13. Each line and load position shall be clearly identified by 3/4 inch minimum block letter labeling.
14. All panels shall be sealable.

APPROVED 	Switchboards 600 Volts and Below	ESR-6
EFFECTIVE DATE 1-11-2002	Electrical Service Requirements ▶ SCE Public ◀	PAGE 6-29

Figure 6-16: Clearances for Residential Multiple Metering Installations

EUSER DRAWING NO. 353

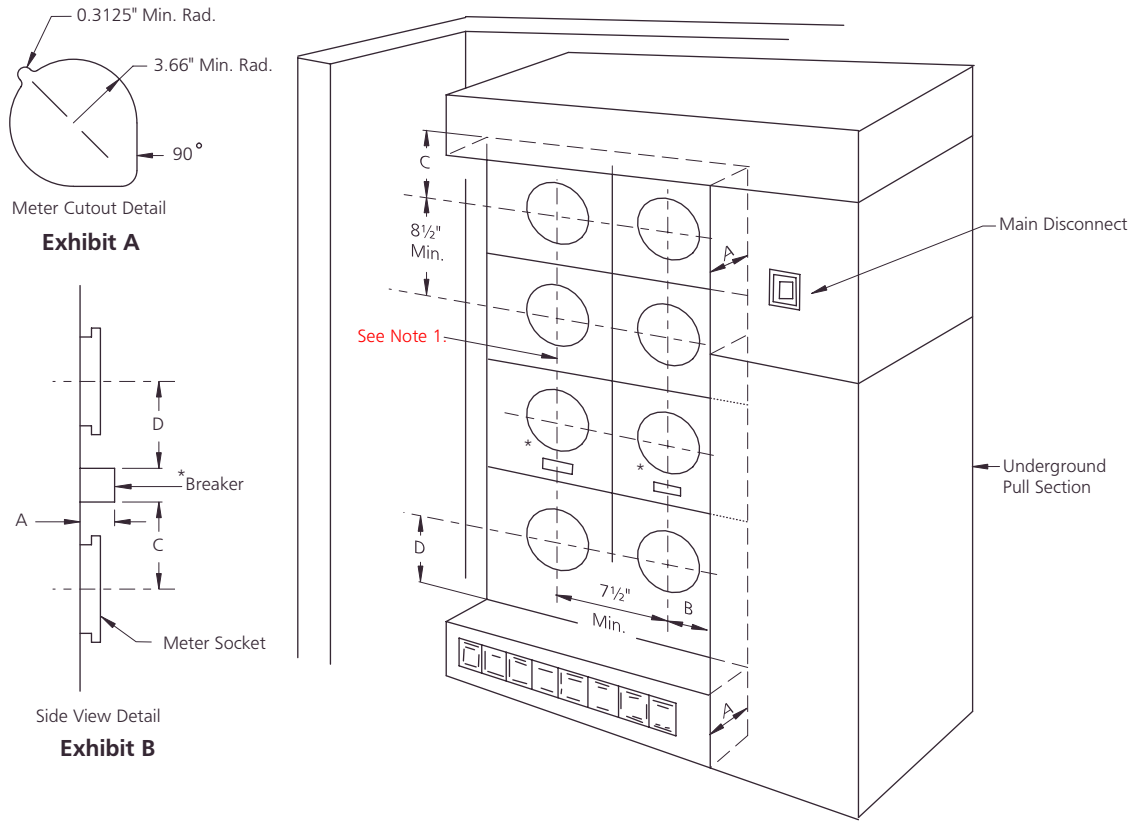

* Alternate Main Disconnect Position Below Meter Socket. See Side View Detail for Clearance Dimension.

DIMENSIONS - INCHES			
"A" (Protrusions)	"B" Min. (in)	"C" Min. (in)	"D" Min. (in)
0 (No protrusion)	3-3/4	4	4-3/4
Greater than 0" to 1-1/8"	4-1/4	4	4-3/4
Greater than 1-1/8" to 2"	4-1/4	4-1/4	6-1/4
Greater than 2" to 4"	6-1/4	4-1/4	8
Greater than 4" to 11" Max.	6-1/4	10	8

Notes

1. Where an adjacent wall or other obstruction extends more than 11 inches perpendicular from the face of the meter panel, a 10 inch minimum dimension to the meter socket axis is required. For obstructions extending 11 inches or less from the meter panel, the side clearance shall conform to that of Dimension "B".
2. Panels shall be removable to provide access to the customers equipment with the utility meters and tamperproof sealing rings in place. When there is more than one meter socket per panel, the minimum meter cutout opening, as detailed in Exhibit A shall apply.
3. Underground landing lugs shall not be placed under any socket cover.
4. Dimension "B" shall be increased by the amount that the main switch door, including operating handle, reduces the clearance when opened 90 degrees.

ESR-6	Switchboards 600 Volts and Below	APPROVED <i>PhH</i>
PAGE 6-30	Electrical Service Requirements ► SCE Public ◀	EFFECTIVE DATE 1-11-2002



5. See **ESR-5: Section ESR-5: "Meters – EXO Installations"** for meter maximum and minimum heights and general requirements.
6. Removable meter panel covers shall not exceed 6 square feet in area.
7. Distribution conductors shall be barred from metering compartment.
8. For single-phase, three-wire, 120/208 volt installations, connect the fifth clip of the meter socket, to the body of the neutral lug, with a minimum #12 stranded copper wire.

APPROVED 	Switchboards 600 Volts and Below	ESR-6
EFFECTIVE DATE 1-11-2002	Electrical Service Requirements ▶ SCE Public ◀	PAGE 6-31

Figure 6-17: 30-Inch Hinged Dual Socket Meter Panel 0-600 Volts

EUSER DRAWING NO. 333

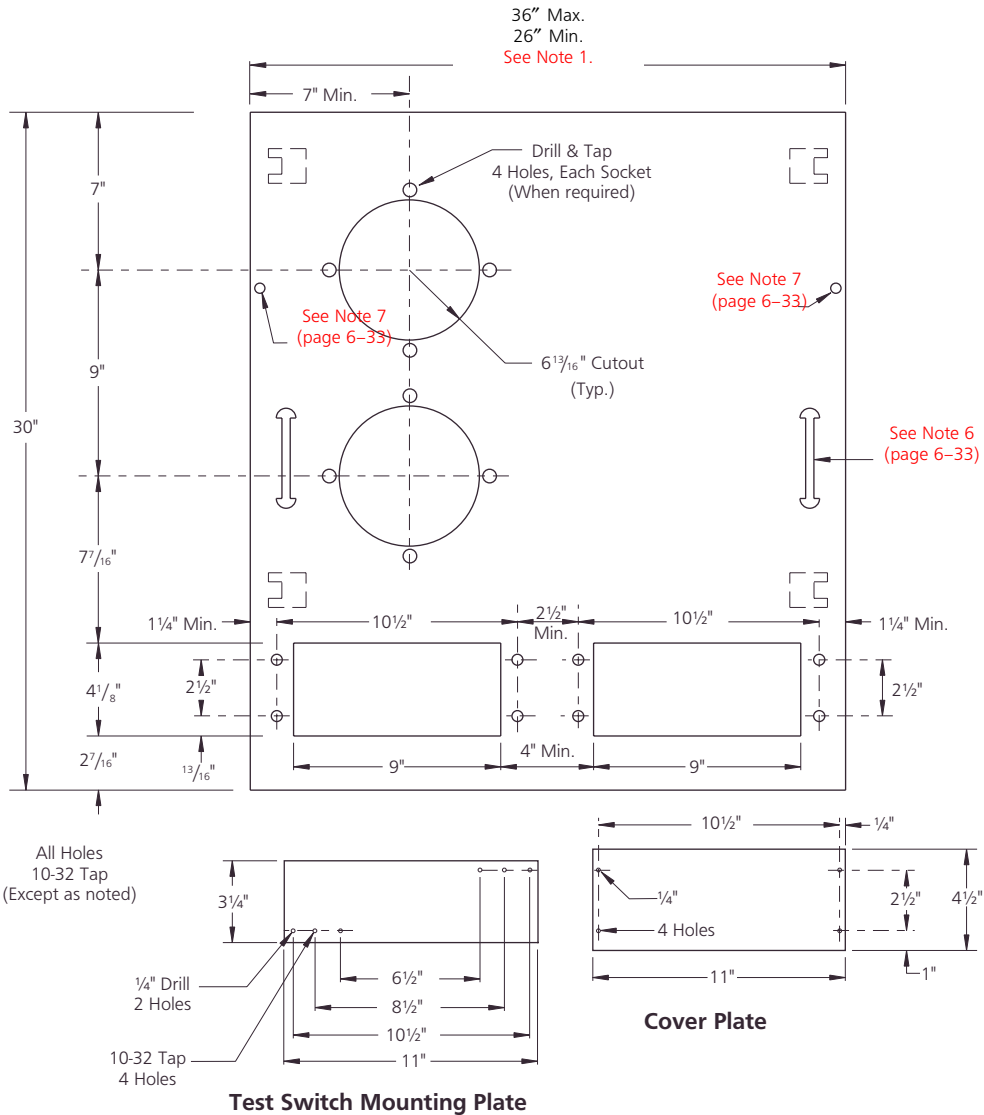

Notes

1. The panel shall be constructed of 12 gauge (minimum) steel and furnished with meter sockets, sealing rings, slotted openings, a removable plate for installation of a secondary test switch, and a cover plate. Slotted openings and removable plate edges shall be smooth to prevent damage to meter wiring.
2. The removable plate shall be attached to the rear of the panel with screws that do not protrude through the face of the panel.
3. Meter sockets shall be designed for back connection.
4. Hinges shall be readily interchangeable, right or left, on the panel and permit the panel to open to 90 degrees. Clevis or removable pin type hinges shall be removable from the top

ESR-6	Switchboards 600 Volts and Below	APPROVED <i>PhH</i>
PAGE 6-32	Electrical Service Requirements ▶ SCE Public ◀	EFFECTIVE DATE 1-11-2002



5. The panel shall support a 25-pound load applied at unsupported end when fully opened with a maximum sag of 1/8 inch.
6. The panel shall have a handle attached to both sides.
7. Stud and wing-nuts shall be sealable when used.
8. See [ESR-5: Table 5-3](#) and [ESR-5: Figure 5-2](#) for meter socket terminal arrangements.

APPROVED 	Switchboards 600 Volts and Below	ESR-6
EFFECTIVE DATE 1-11-2002	Electrical Service Requirements ▶ SCE Public ◀	PAGE 6-33

SWITCHBOARDS ABOVE
600 VOLTS

ESR-7

ESR-7

SWITCHBOARDS ABOVE 600 VOLTS

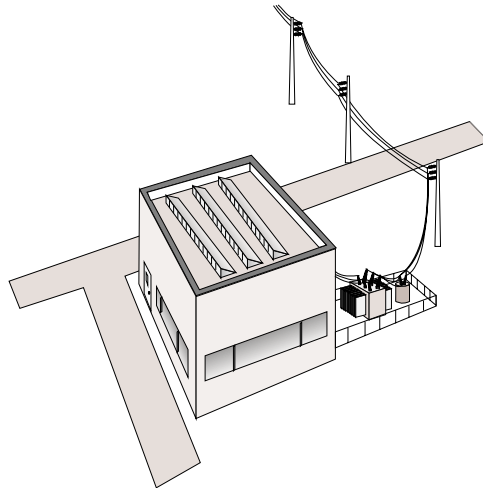

TDBU
► SCE Public ◀

 SOUTHERN CALIFORNIA
EDISON[®]
An EDISON INTERNATIONAL[®] Company

“Copyright © 2004 by Southern California Edison Company.”

**SOUTHERN CALIFORNIA EDISON
TDBU**

ESR-7: Switchboards Above 600 Volts

TABLE OF CONTENTS

Section No.	Title	Page
1.0	General Information	7-4
2.0	Engineering Specifications	7-4
3.0	Manufacturer's Drawings for Approval	7-4
4.0	Service Cable Termination Section.	7-5
5.0	Available Neutral Grounding Schemes.	7-5
6.0	Working Space for High Voltage Switchboards	7-5
7.0	Utility Compartment Labeling	7-6
8.0	Safety Grounding Provisions	7-6
9.0	Meter Panel and Doors	7-6
10.0	BIL Rating.	7-6
11.0	Ventilation Openings	7-6
12.0	Door Access To Metering Cubicle(s)	7-7
13.0	Weatherproofing and Locking.	7-7
14.0	C.T. and V.T. Installations	7-7
15.0	Bus Bars and Conductors	7-7
15.1	Approved Bus Material	7-7
15.2	Bus Dimensions and Spacing.	7-7
15.3	Bus Installation, for Current Transformers	7-7
15.4	Conductors Passing Through Compartment Walls	7-7
16.0	Metering Compartments, General.	7-7
16.1	Insulated Neutral Termination	7-7
16.2	Instrument Transformer Mounting	7-8
16.3	Voltage Transformers Mounting (Unistrut).	7-8
16.4	Current Transformers and Bus Link	7-8
16.5	Test Transformer Supports	7-8
16.6	Phase and Neutral Taps for Fuses and V.T.'s.	7-8
16.7	Fuse Specifications	7-8

APPROVED 	Switchboards Above 600 Volts	ESR-7
EFFECTIVE DATE 1-11-2002	Electrical Service Requirements ▶ SCE Public ◀	PAGE 7-1

TABLE OF CONTENTS

Section No.	Title	Page
16.8	Voltage Transformer Disconnect Requirements	7-8
17.0	Sealing of Metering and Pull Sections	7-9
18.0	Service Connections of Switchboards	7-9
18.1	Underground Service	7-9
18.2	Underground Service Termination Pull Section.	7-9
19.0	Service and Meter Switch	7-9
19.1	Location with Respect to Metering Equipment, Wiring and Devices	7-10
20.0	Switchboard Metering Section	7-10
20.1	Neutral Conductor - 4,160 Volt Service	7-11
20.2	Handles on Hinged Panels.	7-11
20.3	Meter Panel Details.	7-11
20.4	Meter Clearances - Enclosed Meter Panels.	7-11
20.5	Meter Sockets & Test Blocks	7-11
20.6	Meters	7-11
20.7	Test switches and Phasing Transformers	7-12
20.8	Meter locations Prohibited	7-12
20.9	Barriers.	7-12

LIST OF TABLES

Table No.	Title	Page
7-1	High Voltage Utility Metering Section Dimensions	7-14
7-2	High Voltage Busway Service Head Dimensions.	7-20

LIST OF FIGURES

Figure No.	Title	Page
7-1	High Voltage Metering Enclosure 2,400 to 16,500 Volt Service	7-13
7-2	High Voltage Switchboard 2,400 to 16,500 Volt Service	7-15
7-3	Mounting Pattern for Voltage & Current Transformers 2,400 – 16,500 Volt Service	7-16
7-4	Indoor Current Transformer Dimensions for Metering Purposes 5 kV through 15 kV	7-17
7-5	Voltage Transformer (VT) Dimensions 5,000 through 15,000 Volt Outdoor	7-18
7-6	Underground Service Termination Pull Section 2,400 to 16,500 Volts 3 and 4 Wire	7-19

ESR-7	Switchboards Above 600 Volts	APPROVED 
PAGE 7-2	Electrical Service Requirements ▶ SCE Public ◀	EFFECTIVE DATE 1-11-2002

LIST OF FIGURES

Figure No.	Title	Page
7-7	Busway Service Head – 601 to 34,500 Volts 3Ø 3 or 4W.	7-20
7-8	High Voltage Meter Panel Detail – kWh Meter	7-21
7-9	High Voltage Meter Panel Detail – kWh Meter and Control Power Meter.	7-22
7-10	High Voltage Meter Panel Detail – kWh Meter, Control Power Meter and Reactive Meter.	7-23
7-11	Test Switch Layout and Removable Plate Details	7-24
7-12	Control Power Meter Socket—Test Block Wiring Diagram.	7-24
7-13	High-Voltage Switchboards Barrier For Metering Located in Front of C.T. Area	7-25

APPROVED 	Switchboards Above 600 Volts	ESR-7
EFFECTIVE DATE 1-11-2002	Electrical Service Requirements ▶ SCE Public ◀	PAGE 7-3

1.0 General Information

The following requirements apply to switchboards for 2,400, 4,160, 4,800, 7,200, 12,000 and 16,500 volt service installations. Higher voltage service will be considered special and will require detailed instructions for each individual installation. Consult the local service planning office for details.

2.0 Engineering Specifications

Each switchboard for a service exceeding 600 volts will be considered as being specifically engineered.

The Company will issue specifications for each high voltage service installation. These specifications will be based on the application for service, the electrical load and service voltage plans as requested by the customer and the service rules of the Company.

The installation shall comply with all applicable rules of the National Electrical Code (NEC) and other governing codes and ordinances.

3.0 Manufacturer's Drawings for Approval

The designer or manufacturer of high voltage switchboards for the customer's service shall submit three copies of the engineered switchboard drawings which shall include the following illustrations:

- Utility service cable terminating section with dimensions (including view to terminations).
- Main breaker or switch/fuse section (include control power equipment if applicable).
- Front and rear switchboard elevations views with overall dimensions.
- Switchboard plan view.
- Utility metering sections views (including meter panel or meter door).
- Electrical single-line (from service cable terminating pull section to main distribution breakers).

These drawings may include reference to specific pages within this manual, but shall include specific dimensions for service cable pull section and utility metering section.

Drawings are to be submitted prior to switchboard fabrication, to the local Service Planning Office, **ESR-1: Figure 1-1**, where the service is to be installed. Adequate lead-time is necessary to allow for proper review and approvals. One copy of the switchboard drawings will be returned to the sender with approval or necessary corrections. A revised drawings may be requested for final approval once corrections or modifications have been completed. High voltage switchboards drawings are considered approved for fabrication once they are stamped, dated, and approved by a Company representative.

Coordinated breaker trip settings, current transformer ratios, tap settings, time dial settings, relay types, and certified test reports shall be provided to the Company before the service is energized.

This practice will assure the manufacturer of furnishing service sections to the customer that will be suitable with respect to these service requirements and the method of service connection to the Company's facilities.

ESR-7	Switchboards Above 600 Volts	APPROVED 
PAGE 7-4	Electrical Service Requirements ▶ SCE Public ◀	EFFECTIVE DATE 1-11-2002

4.0 Service Cable Termination Section

Every switchboard to which high voltage service is to be supplied shall be equipped with a separate, fully enclosed service cable terminating pull section, see **Figure 7-6 (page 7-19)**. Space will be provided for the support and connection of the service cables to a bused section which has standard NEMA drillings for termination lugs with two-holed tongues. Service cable termination pads for multiple cables, same phase, next to each other, will require a minimum 4 inch horizontal separation between bolt holes measured from center line to center line. The Company will specify the number of cables which it will install and terminate in the pull section. The Company will furnish and install the terminating lugs and bolts.

For service termination's, one landing position shall be provided for each phase and neutral bus for each 400 amperes, or portion thereof, of service ampacity up to 800 amperes. Consult the Company for service termination requirements when the high voltage switchboard ampacity exceeds 800 amperes. All parts must be plated to prevent corrosion.

The service cable terminating pull section shall be equipped with a hinged full width and height opening access door with padlock provisions, and latch to hold the door open a minimum of 90 degrees.

5.0 Available Neutral Grounding Schemes

Where a customer is served directly from a distribution circuit (or an autotransformer), the only available neutral grounding scheme will be that of the distribution circuit.

Where a customer is served by a dedicated two-winding distribution transformer, the following neutral grounding schemes will normally be available:

- Solidly Grounded
- Ungrounded
- Inductance Grounded
- Resistance Grounded (High or Low)
- Resonant Grounded

Where special facilities are necessary to implement a grounding scheme, they shall be furnished and installed at the customer's expense. Consult the local service planning office for neutral grounding scheme details.

6.0 Working Space for High Voltage Switchboards

High voltage switchboards shall be installed with at least 5 feet of clear, level and unobstructed standing and working space in the front, rear and side of any section where such part supports or provides access to metering, testing equipment or service cable termination sections.

Because access is required to both the front and rear of the switchboard, a walk way of at least 2 feet wide shall be provided around both ends of the switchboard. If access to the service cable termination section is from the side of the switchboard, a 5 foot working space shall be provided on the termination section end.

The width of the 5 foot working space in front of the utility sections shall be as wide as the section, but in no case less than 3 feet wide.

When indoor non-raintight (NEMA-1) or outdoor raintight (NEMA-3R) service equipment is installed on an elevated portion of the floor or a housekeeping pad, the pad must extend a minimum of 5 feet in front or rear of the service equipment including metering and service termination sections. If the pad is flush with the front of the equipment, the maximum meter height of 6 feet, 3 inches shall not be exceeded.

APPROVED 	Switchboards Above 600 Volts	ESR-7
EFFECTIVE DATE 1-11-2002	Electrical Service Requirements ▶ SCE Public ◀	PAGE 7-5

To maintain a safe, clear and level working area in front of new or existing meter and service equipment, a concrete slab or other suitable surface, acceptable to the Company may be required.

7.0 Utility Compartment Labeling

Utility compartments shall be permanently labeled with machine engraved laminated phenolic (or equal) tags. Quarter-inch white letters and numbers on red colored material which is readily visible and mechanically attached to the face of the following designated compartments and shall be worded as follows:

- UTILITY VOLTAGE TRANSFORMER COMPARTMENT
- UTILITY VOLTAGE TRANSFORMER FUSE COMPARTMENT
- UTILITY CURRENT TRANSFORMER COMPARTMENT
- UTILITY SERVICE TERMINATION COMPARTMENT
- UTILITY METERING COMPARTMENT

8.0 Safety Grounding Provisions

A section of bare bus 4 inches above and below the current transformers shall be provided to permit the application of Company safety grounds. As an alternate, a grounding perch may be provided on the line and load side of the bus at each current transformer location.

9.0 Meter Panel and Doors

Meter panel and hinges are to be designed to adequately support 25 pounds of load applied at the unsupported end with 1/8 inch maximum sag when opened. A #4 AWG flexible braided bond wire shall be installed across the hinges. A single full width and height meter panel door is required. The door shall be adequately hinged, open to 90° minimum, and support the weight of metering equipment. Meter doors located in front of the current transformers shall have an insulated barrier between the meter door and current transformer compartment. See **Figure 7-13 (page 7-25)**. In addition, see **Section 20.3 (page 7-11)** for meter socket details.

10.0 BIL Rating

BIL (Basic Impulse Level) for the metering enclosure shall be not less than that for the customer's associated switchgear. Reference shall be made to ANSI standards for the minimum acceptable BIL ratings for high voltage switchboards built to the listed nominal voltages shown in the applicable tables "Voltages and Insulation Levels for AC Switchgear Assemblies" and as tabulated for Metal Enclosed Interrupter Switchgear. The metering cubicle shall be labeled with the BIL rating.

For the minimum acceptable BIL rating and insulation class on 16,340 volt switchboards shall be at 125 kV.

11.0 Ventilation Openings

Ventilation openings in covers and doors with provisions for utility seals shall be protected by a rigid barrier. Barriers shall be dimensioned and located so that no live part may be viewed past the barrier when looking through the ventilation opening. Barriers shall be secured to covers and doors with devices that may not be loosened from the outside.

ESR-7	Switchboards Above 600 Volts	APPROVED <i>PhH</i>
PAGE 7-6	Electrical Service Requirements ▶ SCE Public ◀	EFFECTIVE DATE 1-11-2002

12.0 Door Access To Metering Cubicle(s)

For outdoor installations (NEMA 3R), working clearances at the job site may determine if the manufacturer is to furnish either a single or double full height hinged access door. In addition to provisions for a three point latching mechanism with hardware for the installation of a Company padlock. **All** external doors shall, when opened, be equipped with a device to hold the door(s) open to 90 degrees or more.

13.0 Weatherproofing and Locking

Enclosed equipment with weatherproof doors shall meet the following requirements. The meter panel or door shall be hinged on the side opposite that of the outer door on the weatherproof units or hinged on the same side as the outer door without subjecting the metering equipment to damage. Designs shall permit a 90 degree minimum opening of the meter panels or doors with the meters and test facilities in place. The weatherproof doors may be omitted if the equipment is located indoors. If the outer door is omitted, the meter panel must be lockable. The front weatherproof door shall be a single door equipped with a three point latching-type handle to accommodate a Company installed padlock. It shall be equipped with a device to hold the door open to 90 degrees or more.

14.0 C.T. and V.T. Installations

Current transformers and voltage transformers, meters, testing facilities, and all secondary wiring from the transformers to the meters will be furnished and installed by the Company.

15.0 Bus Bars and Conductors

15.1 Approved Bus Material

Only copper or plated aluminum bus shall be used in the metering and terminating enclosure. Aluminum bus shall be identified with the plating process where the service cables terminate and the current transformers are mounted.

15.2 Bus Dimensions and Spacing

Maximum bus size shall be 3/8 inch x 4 inches. Minimum bus size shall be 1/4 inch x 2 inches unless otherwise indicated on specific drawings. Bus sizes outside of these limits require special engineering and consultation with the Company.

15.3 Bus Installation, for Current Transformers

When the main switch or circuit breaker enclosure is adjacent to and on the source side of the metering enclosure, connections from the load side of the main switch or circuit breaker to the line side of the current transformers shall be made using bus bars.

15.4 Conductors Passing Through Compartment Walls

Where buses or conductors pass through compartment walls, through-the-wall bushings, or insulated construction with full voltage rating of the switchboard may be used.

16.0 Metering Compartments, General

16.1 Insulated Neutral Termination

When an insulated neutral is required, it shall have full-voltage rated insulation from the metering cubicle. Consult the local service planning office to determine if an insulated neutral is required.

APPROVED 	Switchboards Above 600 Volts	ESR-7
EFFECTIVE DATE 1-11-2002	Electrical Service Requirements ▶ SCE Public ◀	PAGE 7-7

16.2 Instrument Transformer Mounting

Voltage transformer and current transformer mounting platforms are to be provided by the manufacturer.

16.3 Voltage Transformers Mounting (Unistrut)

The front unistrut mounting bar shall position the voltage transformer mounting holes 9 inches from the inside of the voltage transformer compartment access door. See [Figure 7-3 \(page 7-16\)](#) for details. The rear unistrut mounting bar shall be continuously adjustable 5 inches minimum to 13 inches maximum from the front unistrut bar.

16.4 Current Transformers and Bus Link

Unless otherwise directed by the Company representative, each switchboard bus drilling and dimensions for installing current transformers shall accommodate the pattern for 800 ampere or less current transformers of the proper voltage insulation class, see [Figure 7-4 \(page 7-17\)](#). Current transformer center phase position shall be bused straight through with removable links on all high voltage switchboards. This bus provided by the manufacturer, shall consist of a removable link dimensioned the same as the current transformer bars on the metered phases.

16.5 Test Transformer Supports

Phenolic test transformer supports for each phase (Two – 1/2" x 2" x 8") or a continuous bar of insulating material across the compartment is required for switchboards 4,160 volts and below. See [Figure 7-13 \(page 7-25\)](#).

16.6 Phase and Neutral Taps for Fuses and V.T.'s

Lugs for voltage transformer phase and neutral connections shall be provided in the voltage transformer compartment. Mechanical lugs shall allow for #8 AWG through 1/0 AWG connections.

16.7 Fuse Specifications

Voltage transformer fuses will be furnished and installed by the Company. Access to fuses shall be provided through voltage transformer compartment only. The manufacturer shall provide the mounting clips for indoor current limiting fuses with mounting clips separation and fuse ferrule diameter appropriate for the voltage rating of the equipment, see [Table 7-1 \(page 7-14\)](#).

16.8 Voltage Transformer Disconnect Requirements

For personal safety, Kirk Key (or equivalent) interlocking is required between the voltage transformer disconnect switch and the voltage transformer access compartment door. The voltage transformer compartment cannot be entered until all of the following conditions are met:

- The gang-operated disconnect is fully and visibly open; and visibly grounded.
- When the voltage transformer disconnect is fully open, the main disconnect blades must ground automatically.
- The disconnect switch is locked open with a key interlock system.

The interlock system must prevent closing of the disconnect switch without first closing and locking the voltage transformer compartment. Two interlocking keys shall be provided.

ESR-7	Switchboards Above 600 Volts	APPROVED 
PAGE 7-8	Electrical Service Requirements ▶ SCE Public ◀	EFFECTIVE DATE 1-11-2002

Primary and grounding contacts for the voltage transformer disconnect blades shall be of the blade and jaw design or equivalent to assure continued adequate contact.^{1/}

Operating handle or lever of the voltage transformer disconnect switch shall be padlockable in the closed position.

The voltage transformer disconnect shall be tapped ahead (supply side) of the utility metering current transformers.

17.0 Sealing of Metering and Pull Sections

Service terminating pull sections and metering sections shall be fully enclosed. All hinged panels that will give access to these sections or to any secondary meter wiring shall be sealable. Bus ports through the side barriers of the metering section shall be closed with phenolic barriers or otherwise arranged to prevent access to the metering section.

18.0 Service Connections of Switchboards

18.1 Underground Service

Underground service will be supplied under the Company's rules covering underground service from the source. Refer to ESR-4

Company Owned Transformers on Customer's Premises relative to underground service from transformer vaults, rooms and outdoor enclosures. See [ESR-3: Section 6.0 "Underground Service From An Overhead Source"](#) relative to underground service from an overhead source or from an underground distribution system.

18.2 Underground Service Termination Pull Section

Every switchboard to which underground service is to be supplied by the Company shall be equipped with a fully enclosed service terminating pull section by the manufacturer. The pull section will be a part of the switchboard service section(s).

The detailed requirements of an underground pull section showing the cables and termination's as installed by the Company is shown in [Figure 7-6 \(page 7-19\)](#).

The maximum load that will be supplied through a single cable or set of cables in a single conduit will be determined by the Company. Consult the Company for conduit requirements.

The underground service conduit shall normally enter the bottom of the pull section as shown in [Figure 7-6 \(page 7-19\)](#). Where this method of entry does not appear to be practicable, consult the local service planning office. Any change will require an increase in the size of the pull section together with special terminating provisions.

19.0 Service and Meter Switch

The manufacturer or contractor shall furnish and install a single main service disconnect with every switchboard in which the Company's metering equipment is to be installed. Such disconnect shall control all of, and only, the energy carried by the service to and registered by the metering equipment. Where more than one set of metering equipment is supplied through the same service, a main service disconnect, as required by the California Electrical Safety Orders, shall be installed on the supply side (old sequence) of all individual meter switches in the installation.

1/ Wiping or pressure contacts are not acceptable.

APPROVED 	Switchboards Above 600 Volts	ESR-7
EFFECTIVE DATE 1-11-2002	Electrical Service Requirements ▶ SCE Public ◀	PAGE 7-9

Where a customer is served directly from a distribution circuit (or an autotransformer), the main disconnect shall be a circuit breaker with overcurrent and ground relaying provisions.

Where a customer is served by a dedicated two-winding power transformer, it is likely that the main disconnect will need to be a circuit breaker with overcurrent protection and ground relaying provisions. Consideration will be given to the use of a switch and fuse combination with current carrying and interrupting capacities acceptable to the Company only if it is determined that the fuse size being considered will properly coordinate with the Company's dedicated two-winding power transformer protection. Consult the local service planning office regarding available fault duties and protection coordination.

19.1 Location with Respect to Metering Equipment, Wiring and Devices

2,400, 4,160, 4,800, 7,200, 12,000 and 16,500 volt services.

The main service disconnect **shall** be installed and connected to the service on the supply side of all metering equipment, wiring and devices except as follows:

Where an electrically operated main meter and service breaker is operated by alternating current, a transformer for supply of such control power and/or for heating, lighting and other incidental use within the switchboard may be installed in the switchboard connected to the service through suitable protection on the supply side of the main service breaker. The secondary leads from this transformer shall be taken through a four or seven clip meter socket connected on the supply side of all load. If or when power from this meter is to serve voltage sensing relays or other types of equipment that will render removal of this meter for testing or replacement prohibitive, test by-pass facilities shall be provided by the manufacturer and wired through the 4 or 7 clip meter socket on the meter door. See [Figure 7-9 \(page 7-22\)](#) or [Figure 7-10 \(page 7-23\)](#) for requirements.

On installations where this meter can be removed without having an adverse effect on the main power source, a meter switch or test by-pass facilities in the control supply circuit is not required. The manufacturer shall indicate this characteristic on drawings.

The Company will install a meter in the 4 or 7 clip meter socket installed on the meter panel for the control supply circuit. The energy supplied through this meter will be billed as a separate account.

Where specifically permitted by the Company, apparatus for voltage indication only may be installed (non-metered) on the supply side of the main disconnect. A maximum low voltage fuse size of 1.0 ampere is allowed for this application.

When approved by the Company, lighting arresters may be installed on the supply side of the main breaker. They shall be located in an area separately barriered from sections containing utility equipment (pull sections and/or meter sections).

20.0 Switchboard Metering Section

The design of the switchboard metering section(s) varies with the service voltage, the character of the metering equipment involved, indoor or raintight construction and the point at which the load leaves the section. Acceptable types of switchboards have meters, instrument transformers and high voltage test sections normally installed in one cubicle or section.

The detailed requirements for dimensions, clearances, bus and compartments are shown in [Figure 7-1 \(page 7-13\)](#).

Provisions for mounting voltage transformers shall be made in the utility voltage transformer compartment which will permit their primary terminals to be conveniently connected to the fuse carriers. This location must also provide access for the easy installation and removal of the voltage transformer fuses.

ESR-7	Switchboards Above 600 Volts	APPROVED 
PAGE 7-10	Electrical Service Requirements ▶ SCE Public ◀	EFFECTIVE DATE 1-11-2002

20.1 Neutral Conductor - 4,160 Volt Service

All switchboards for 4,160 volt service (except those with resistor grounded neutrals) are metered 4-wire and employ three 2,400 volt voltage transformers, each connected between a phase and neutral. This arrangement requires a separate continuous neutral conductor (5 kV insulated) to be installed into the voltage transformer compartment from the service cable terminating pull section. Where the customer utilizes a three-wire system, the neutral can be a #6 conductor as it supplies only metering potential. The separate neutral conductor from the terminating pull section to the voltage transformer compartment shall be supplied by the manufacturer.

When the neutral of a 4,160 volt circuit is grounded through a resistor, (3-phase, 3-wire), the neutral shall not be brought into the metering compartment and two 4,160 volt voltage transformers shall be used with two current transformers. The center phase bus link shall be provided the manufacturer.

20.2 Handles on Hinged Panels

Each hinged panel giving access to utility sections/compartments shall be sealable and equipped with a handle opposite the hinged side. Hinged panels are not limited to size.

20.3 Meter Panel Details

Meter panels or doors shall include a minimum of two 15 clip meter sockets and two test switch openings. Refer to [Figure 7-10 \(page 7-23\)](#). If the switchboard requires control power metering, a 4 clip for single-phase or 7 clip for three-phase meter socket with test by-pass blocks shall be included.

Refer to [Figure 7-8 \(page 7-21\)](#), [Figure 7-9 \(page 7-22\)](#) and [Figure 7-10 \(page 7-23\)](#) for details.

20.4 Meter Clearances - Enclosed Meter Panels

Whenever a switchboard meter panel is in an enclosure, arrangements shall be made which will provide working clearance around and in front of the meters, test switches, phasing transformers, etc. The enclosure depth in front of the meter panels shall be at least 11 inches. The meter heights shown in [ESR-6: Section 4.0 "Meters and Meter Panels"](#) will apply.

20.5 Meter Sockets & Test Blocks

All meter sockets, 100 Amp test by-pass blocks, and related wiring for control power metering (4 or 7 clip socket) shall be provided by the manufacturer. Conductors between test by-pass blocks and control power source shall be identified by phase and line or load. The manufacturer is to terminate the control power metering conductors at the test by-pass blocks (line-load sequence) and 4 or 7 clip meter socket. See [Figure 7-12 \(page 7-24\)](#). Labels identifying LINE & LOAD sequence shall be placed under the test blocks on the panel.

20.6 Meters

Meters shall be installed in weatherproof switchgear (NEMA-3R) when outdoors. In certain areas, a walk-in enclosure for the metering equipment may be required due to unusual weather conditions. Consult the local service planning office for requirements of outdoor installations.

APPROVED 	Switchboards Above 600 Volts	ESR-7
EFFECTIVE DATE 1-11-2002	Electrical Service Requirements ▶ SCE Public ◀	PAGE 7-11

20.7 Test switches and Phasing Transformers

Test switch and phasing transformer cutouts on meter panels shall be provided as illustrated in **Figure 7-11 (page 7-24)**. The manufacturer is to provide a removable plate with each meter panel cutout.

20.8 Meter locations Prohibited

The prohibited meter locations specified in **ESR-5: Table 5-2** apply to meters on all switchboards.

20.9 Barriers

Specific switchboards designed with metering door in front of current transformers, shall have a full height and width insulated barrier between the meter panel or door and the C.T. compartment to isolate the worker from any high voltage conductors. A barrier is not required when metering is located in front of the voltage disconnect compartment. See **Figure 7-13 (page 7-25)**.

ESR-7	Switchboards Above 600 Volts	APPROVED <i>PhH</i>
PAGE 7-12	Electrical Service Requirements ▶ SCE Public ◀	EFFECTIVE DATE 1-11-2002

Figure 7-1: High Voltage Metering Enclosure 2,400 to 16,500 Volt Service

EUSER DRAWING NO. 407

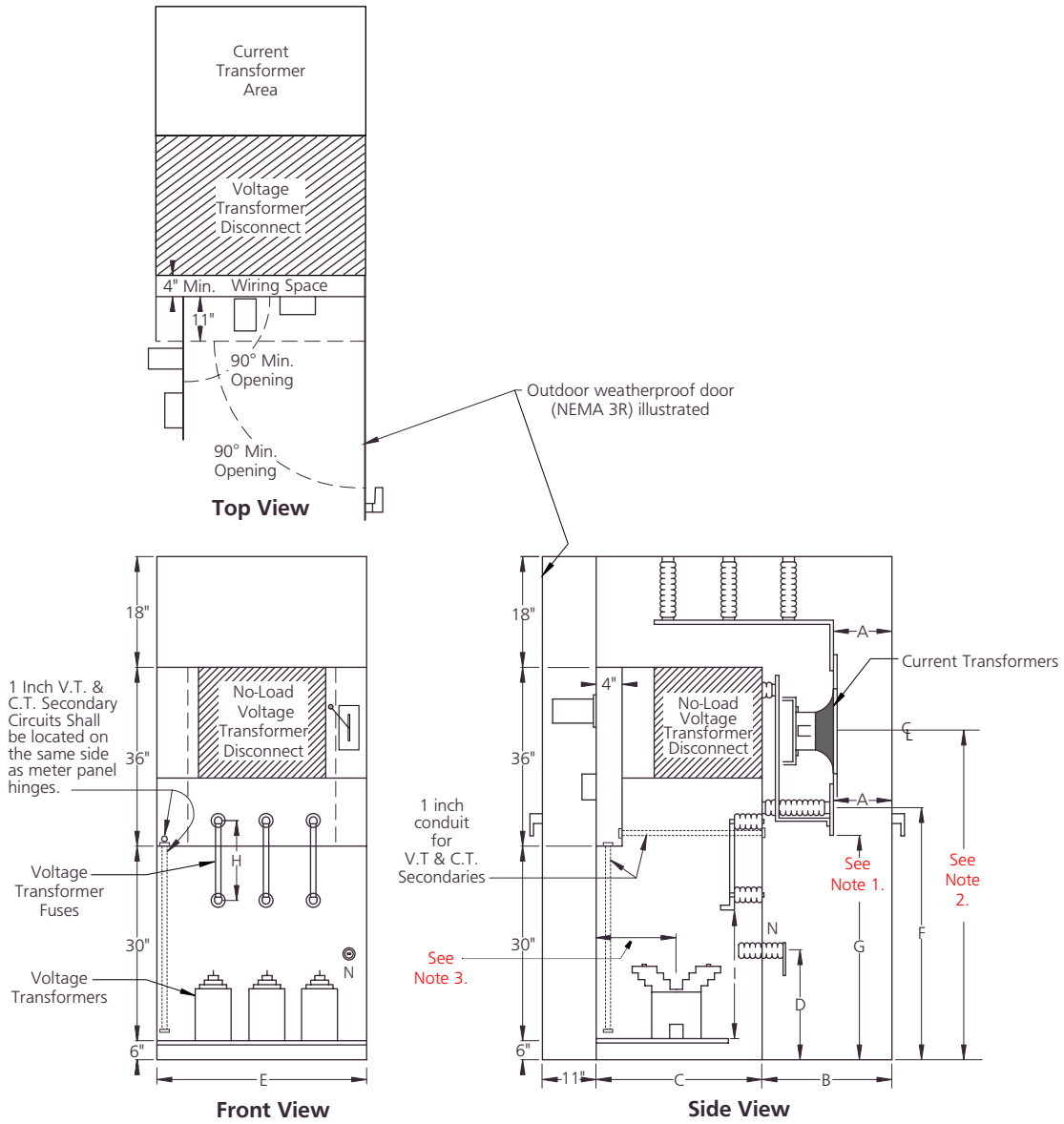

Notes

1. Not a Cable Termination Section.
2. 48 inch min., 60 inch max.; glastic barrier required if meter door is located in front of current transformer area see Figure 7-13 (page 7-25).
3. See side view Figure 7-3 (page 7-16)
4. This illustration depicts typical metering panel in front of voltage transformer disconnects. Metering may be located in front of C.T. area.
5. See Table 7-1 (page 7-14) for dimensions of high voltage metering enclosures.
6. Primary taps for VTs shall be connected to the line side of the metering CTs

APPROVED <i>PhH</i>	Switchboards Above 600 Volts	ESR-7
EFFECTIVE DATE 1-11-2002	Electrical Service Requirements ▶ SCE Public ◀	PAGE 7-13

Table 7-1: High Voltage Utility Metering Section Dimensions

Specifications	Voltage Rating Dimensions		
	2400	4160/4800	7200/17000
Minimum Bare BUS Clearance Ø to Ground	3-1/2"	3-1/2"	6"
Minimum Bare BUS Clearance Ø to Ø	5"	5"	7-1/2"
Dimension A	5" Min. 10" Max.	5" Min. 10" Max.	8" Min. 10" Max.
Dimension B	24" Min.	24" Min.	24" Min.
Dimension C	24" Min.	24" Min.	24" Min.
Dimension D	12" Min.	12" Min.	12" Min.
Dimension E	36" Min.	48" Min.	48" Min.
Dimension F	42" Min. 48" Max.	42" Min. 48" Max.	42" Min. 48" Max.
Dimension G Not A Cable Termination Section	N/A	N/A	N/A
Dimension H Fuse Mounting Clip Center	8-1/2"	8-1/2"	11-1/2"
Dimension H Fuse Ferrule Diameter	1-5/8"	1-5/8"	1-5/8"
Dimension I	18" Min.	18" Min.	18" Min.

ESR-7	Switchboards Above 600 Volts	APPROVED <i>PhH</i>
PAGE 7-14	Electrical Service Requirements ► SCE Public ◀	EFFECTIVE DATE 1-11-2002

Figure 7-2: High Voltage Switchboard 2,400 to 16,500 Volt Service

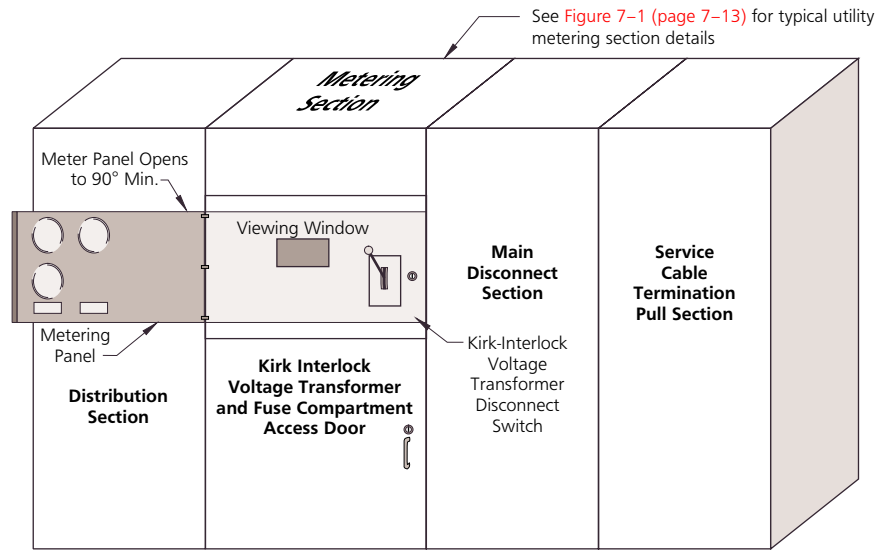

FRONT VIEW (TYPICAL) INDOOR

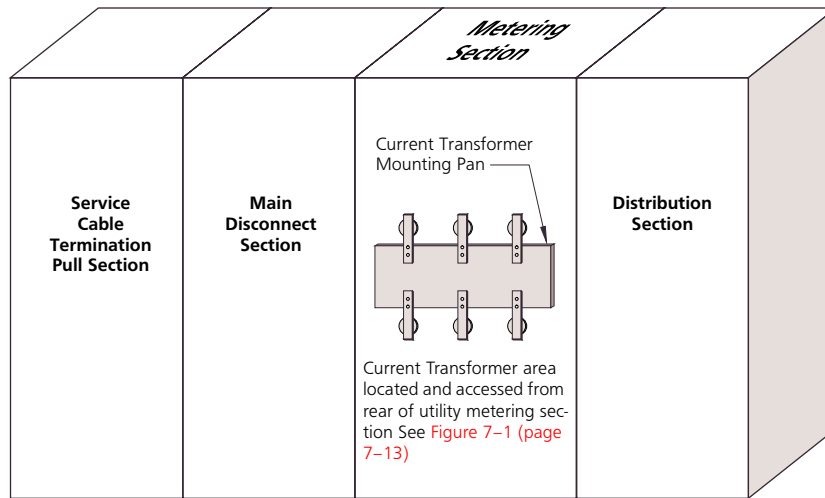

REAR VIEW (TYPICAL) INDOOR

Notes:

1. This illustration depicts a typical metering panel in front of voltage transformer disconnects. Metering may be located in front of the C.T. area.
2. Current transformer center phase position shall be bused straight through with removable links on all high voltage switchboards.

APPROVED 	Switchboards Above 600 Volts	ESR-7
EFFECTIVE DATE 1-11-2002	Electrical Service Requirements ▶ SCE Public ◀	PAGE 7-15

**Figure 7-3: Mounting Pattern for Voltage & Current Transformers
 2,400 – 16,500 Volt Service**

EUSER DRAWING NO. 408

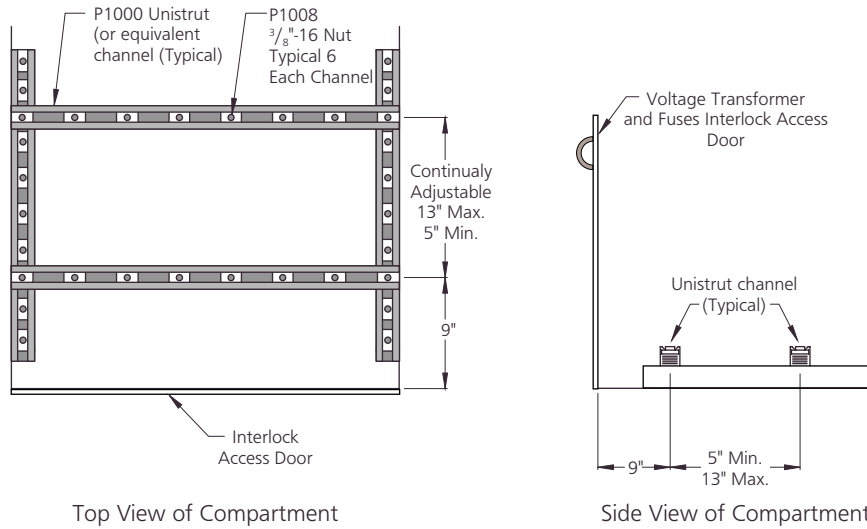

Top View of Compartment

Side View of Compartment

**Voltage Transformer Mounting Rail Detail
 (Unistrut Type)**

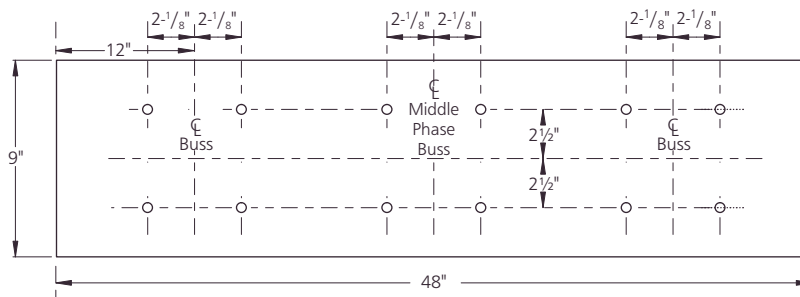

Current Transformer Mounting Base

See Figure 7-4 (page 7-17)
 (Tap All Holes 3/8"-16 or use a cage nut.)

<p>ESR-7</p>	<p>Switchboards Above 600 Volts</p>	<p>APPROVED </p>
<p>PAGE 7-16</p>	<p>Electrical Service Requirements ▶ SCE Public ◀</p>	<p>EFFECTIVE DATE 1-11-2002</p>

Figure 7-4: Indoor Current Transformer Dimensions for Metering Purposes 5 kV through 15 kV

EUSER DRAWING NO. 414

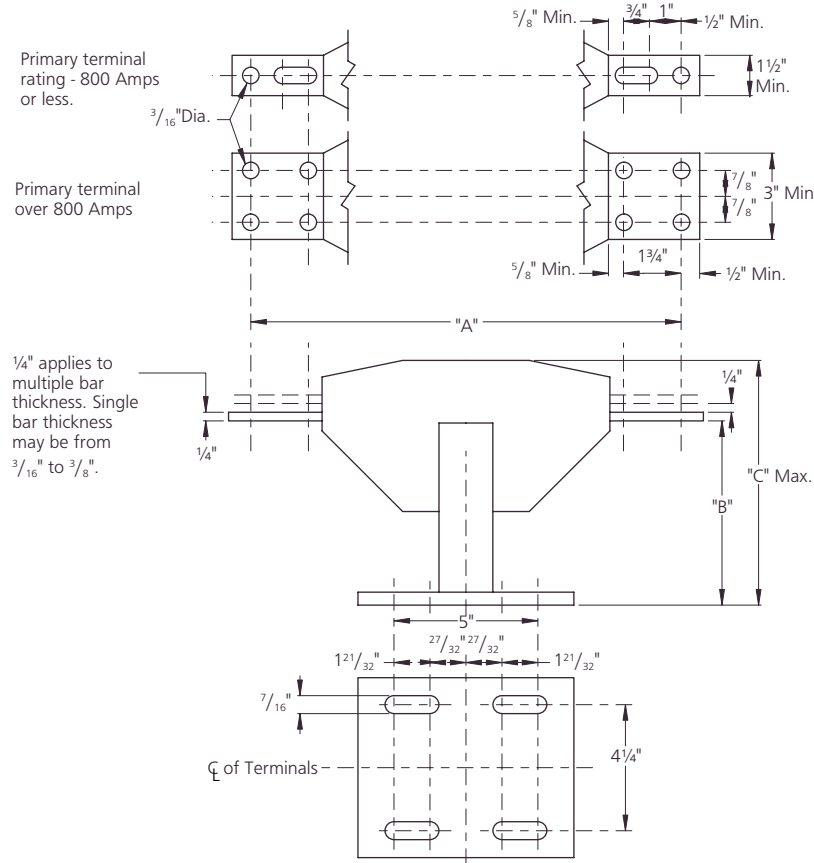

C.T. Mounting Hole Pattern

See Figure 7-3 (page 7-16) for entire mounting base dimensions.

Notes:

1. Insulation classes are 5-, 8.7- and 15-kV.
2. Basic impulse insulation levels (BIL) for these classes are 60-, 75- and 110-kV respectively.
3. Bus drilling and dimensions shall accommodate 800 amperes or less. See Section 16.4 (page 7-8)

Dimensions ^(a) — Inches ^(b)						
Insulation Class	"A"		"B"		"C" (Maximum)	
	Amperes		Amperes		Amperes	
	0-800	1200-2000	0-800	1200-2000	0-800	1200-2000
5.0	14	—	5-3/4	—	8	—
8.7	15	—	8	—	10-1/2	—
15.0	22	26	9	5-3/4	11-1/4	13

- (a) Contact the Company representative for dimensions above 15 kV.
 (b) Unless otherwise indicated tolerance, plus or minus 1/16 inch.

APPROVED <i>PhH</i>	Switchboards Above 600 Volts	ESR-7
EFFECTIVE DATE 1-11-2002	Electrical Service Requirements ▶ SCE Public ◀	PAGE 7-17

Figure 7-5: Voltage Transformer (VT) Dimensions 5,000 through 15,000 Volt Outdoor

EUSER DRAWING NO. 416

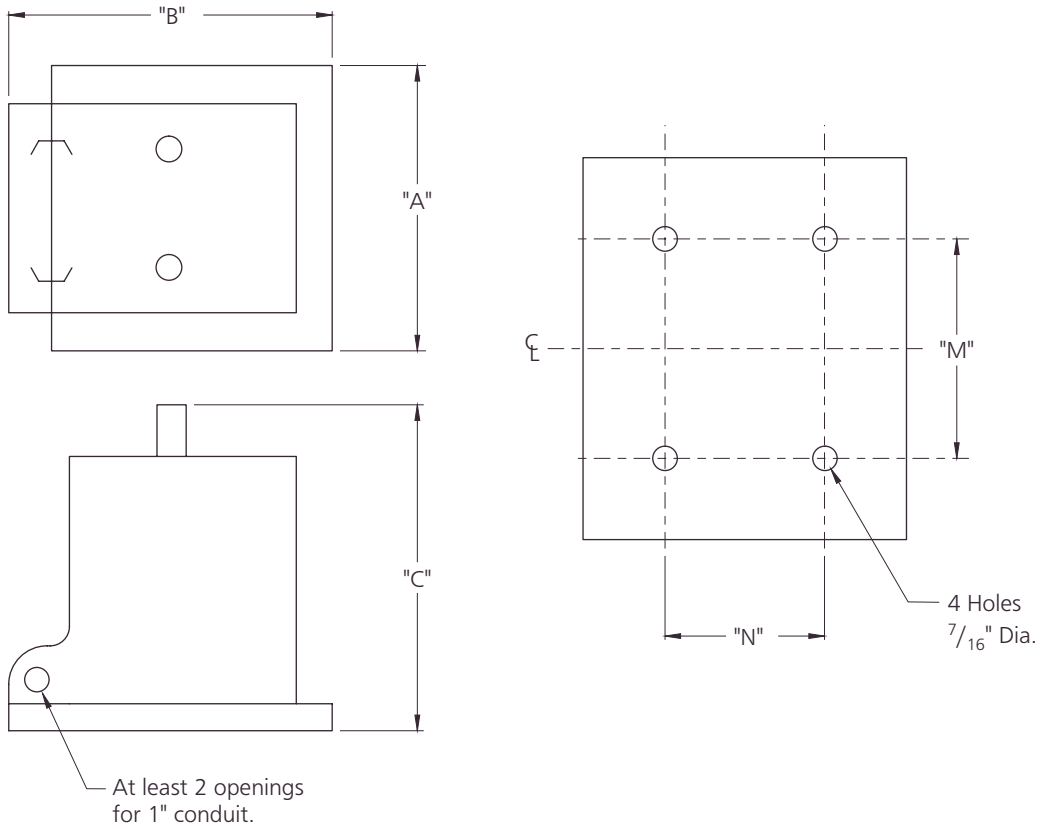

Dimensions – Inches ^(a)					
Insulation Class kV	Without Mounting Brackets				
	Maximum Overall Dimensions			Mounting Dimensions	
	"A"	"B"	"C"	"M"	"N"
5.0	11-1/2	13	13	8-1/2	6-1/4
8.7	14-1/2	15-1/2	18-1/2	10	8-5/8
15.0	14-1/2	15-1/2	18-1/2	10	8-5/8

(a) Unless otherwise indicated tolerance – plus or minus 1/16 inch.

ESR-7	Switchboards Above 600 Volts	APPROVED <i>PhH</i>
PAGE 7-18	Electrical Service Requirements ▶ SCE Public ◀	EFFECTIVE DATE 1-11-2002

Figure 7-6: Underground Service Termination Pull Section 2,400 to 16,500 Volts 3 and 4 Wire

EUSER DRAWING NO. 417

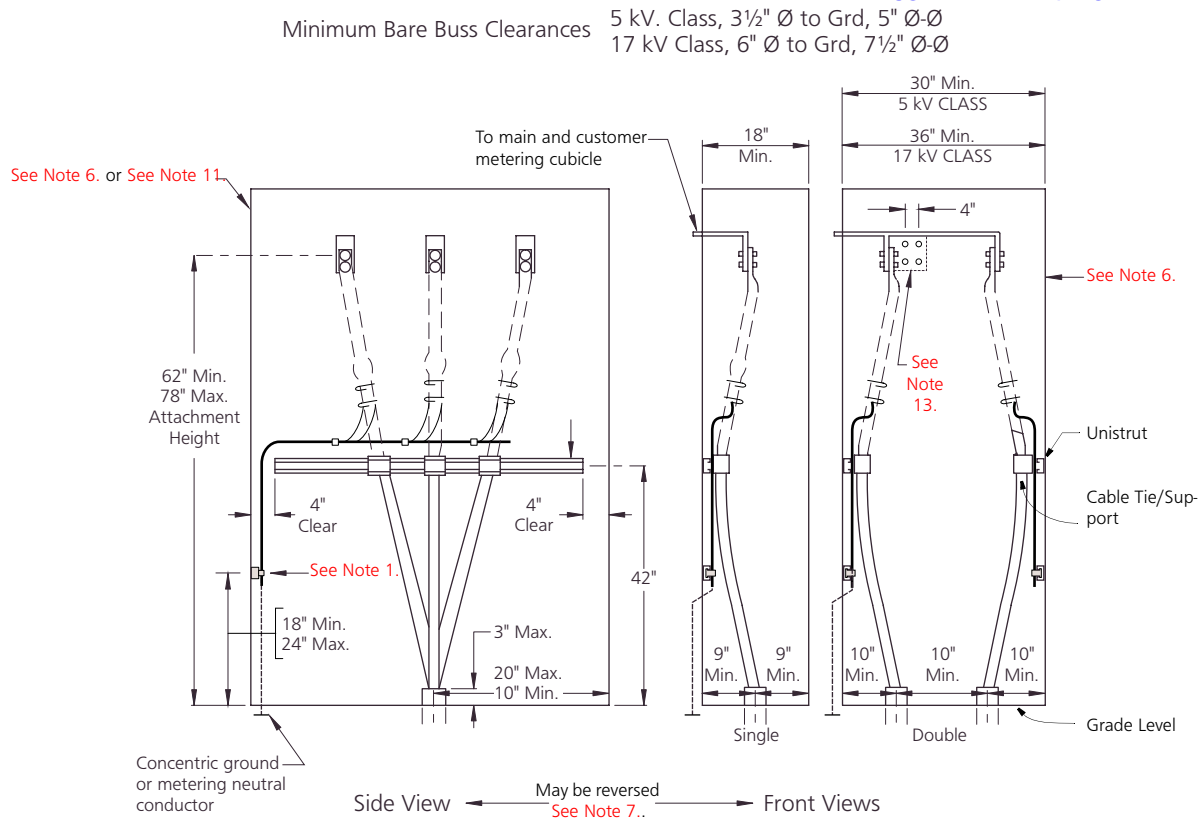

Notes

1. Provide an insulated terminal for service cable concentric wires and/or service neutral terminations. The connector shall accept a range of wire sizes from #2 through #4/0 AWG. A separate neutral conductor for 4-wire metering is to extend to the metering voltage transformer compartment.
2. Service cable will be furnished and installed by the company in accordance with the company's rules and requirements for supply of underground service.
3. Accommodation will be required for one set of service cables for each 400 amperes or fraction thereof of service ampacity up to 800 amperes. Consult the Company for service termination requirements when the service ampacity exceeds 800 amperes. See ESR-6: Figure 6-6 for single position cable terminations drilling.
4. The company will designate the number, location and size of service conduits, type of pull section and number of terminations required.
5. The pull section may be in any suitable location on the switchboard, provided its hinged access panels face a clear accessible working space extending at least 5 feet in front of the section and is at least 3 feet wide.
6. The hinged enclosing panels shall each be sealable and equipped with a handle opposite the hinged side. Hinged panels are not limited to size.
7. The hinged enclosing panels shall normally be front or back or side. Hinged enclosing panels shall require a 12 inch minimum access distance to buses, measured from the buses to the panels with panels in place.
8. Furnish and install one piece of Unistrut P-1000 (or equivalent) channel as shown.
9. BIL for pull section shall be not less than that for the customer's associated switchgear.
10. No connections or customer equipment (except heating elements) is permitted in the underground termination pull section.
11. A single full length and width access door with three point latch and padlock provisions is required. The door must open a minimum of 90 degrees and be latchable, to hold the door open. The access door shall maintain a minimum 6 inch clearance measured from bus to inside of access door.
12. Non-access sides of pull section shall maintain minimum bare bus clearance.
13. Alternate multiple cable pad is acceptable with 4 inch minimum horizontal bolt separation on double cable enclosures.

APPROVED <i>Ph.H</i>	Switchboards Above 600 Volts	ESR-7
EFFECTIVE DATE 1-11-2002	Electrical Service Requirements ► SCE Public ◀	PAGE 7-19

Figure 7-7: Busway Service Head – 601 to 34,500 Volts 3Ø 3 or 4W

EUSER DRAWING NO. 418

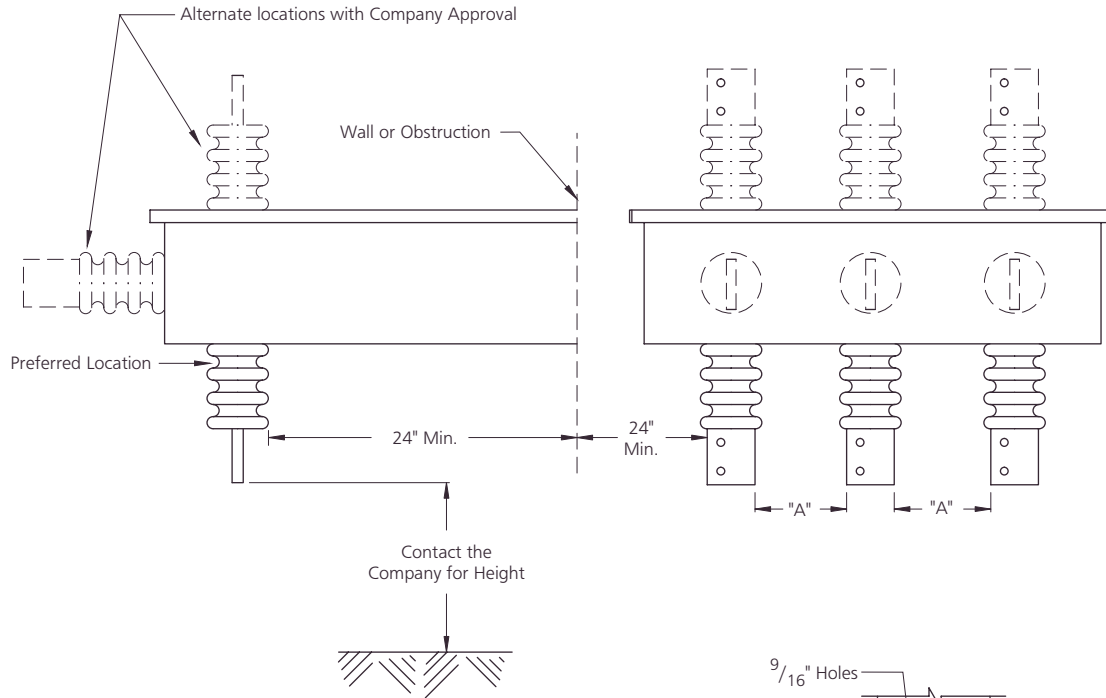
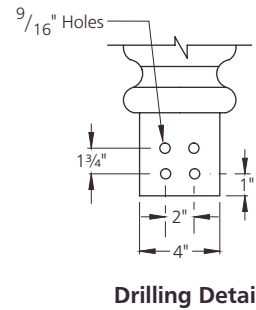

Table 7-2: High Voltage Busway Service Head Dimensions

kV	Dimension A (in)
5	7
7.9	10
12	12
16	12
34.5	24



Notes:

1. Number of lug positions to be specified by the Company.
2. Bushings to be spaced as shown in table above.
3. All bushings shall meet NEMA standards for creep distance, except 17 kV which shall have 15 inch min. creep distance.

ESR-7	Switchboards Above 600 Volts	APPROVED <i>PhH</i>
PAGE 7-20	Electrical Service Requirements ► SCE Public ◀	EFFECTIVE DATE 1-11-2002

Figure 7-8: High Voltage Meter Panel Detail – kWh Meter

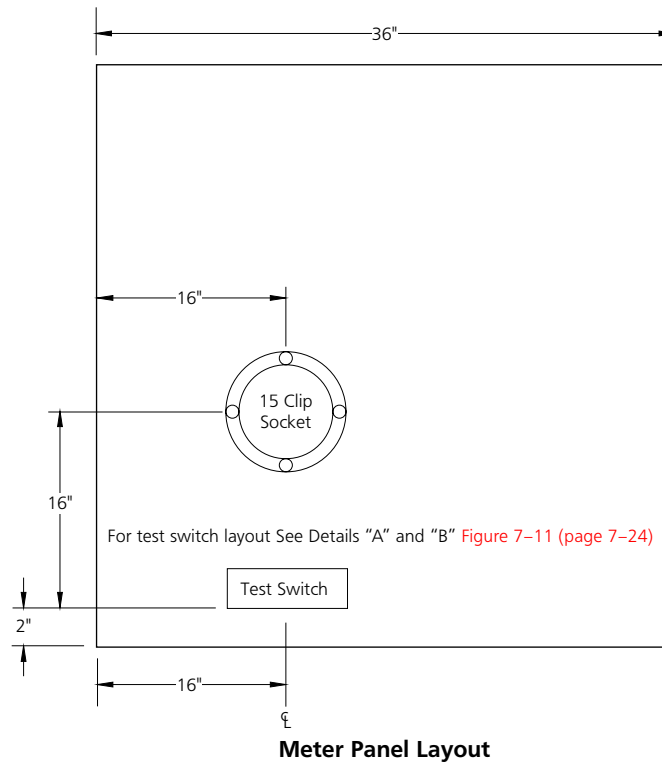

Notes:

1. Provide ring type meter sockets with clips as indicated. Screws used to mount cast meter sockets to hinged panels shall provide a 1/8 inch minimum clearance between the screw head and the back of the meter socket ring.
2. Meter panel door handle to be provided opposite hinged panel side.

APPROVED 	Switchboards Above 600 Volts	ESR-7
EFFECTIVE DATE 1-11-2002	Electrical Service Requirements ▶ SCE Public ◀	PAGE 7-21

Figure 7-9: High Voltage Meter Panel Detail – kWh Meter and Control Power Meter

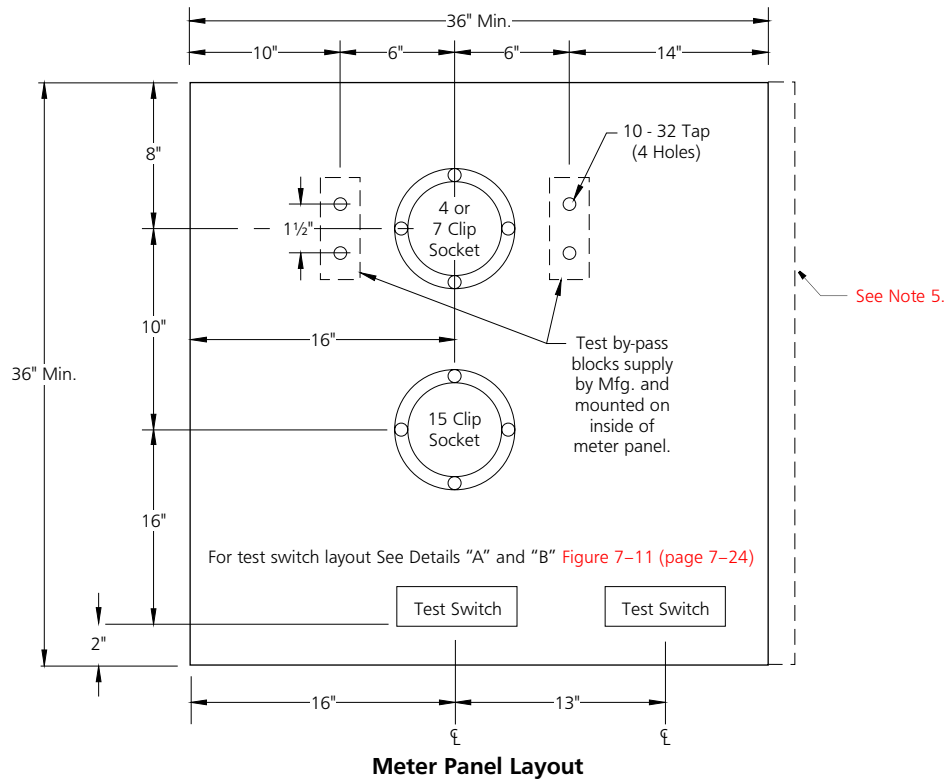

Notes:

1. Provide ring type meter sockets with clips as indicated. Screws used to mount cast meter sockets to hinged panels shall provide a 1/8 inch minimum clearance between the screw head and the back of the meter socket ring.
2. Control power secondary conductors provided for metering shall be terminated by manufacturer at test by-pass blocks and 4 and 7 clip meter socket; wired line-load sequence.
3. Meter panel door handle to be provided opposite hinged panel side.
4. See [Control Power Meter Socket—Test Block Wiring Diagram, Figure 7-12 \(page 7-24\)](#).
5. The panel may be extended on the hinged side when used with weatherproof (NEMA 3R) enclosures and three meter panel door hinges are provided.

ESR-7	Switchboards Above 600 Volts	APPROVED <i>PhH</i>
PAGE 7-22	Electrical Service Requirements ▶ SCE Public ◀	EFFECTIVE DATE 1-11-2002

Figure 7-10: High Voltage Meter Panel Detail – kWh Meter, Control Power Meter and Reactive Meter

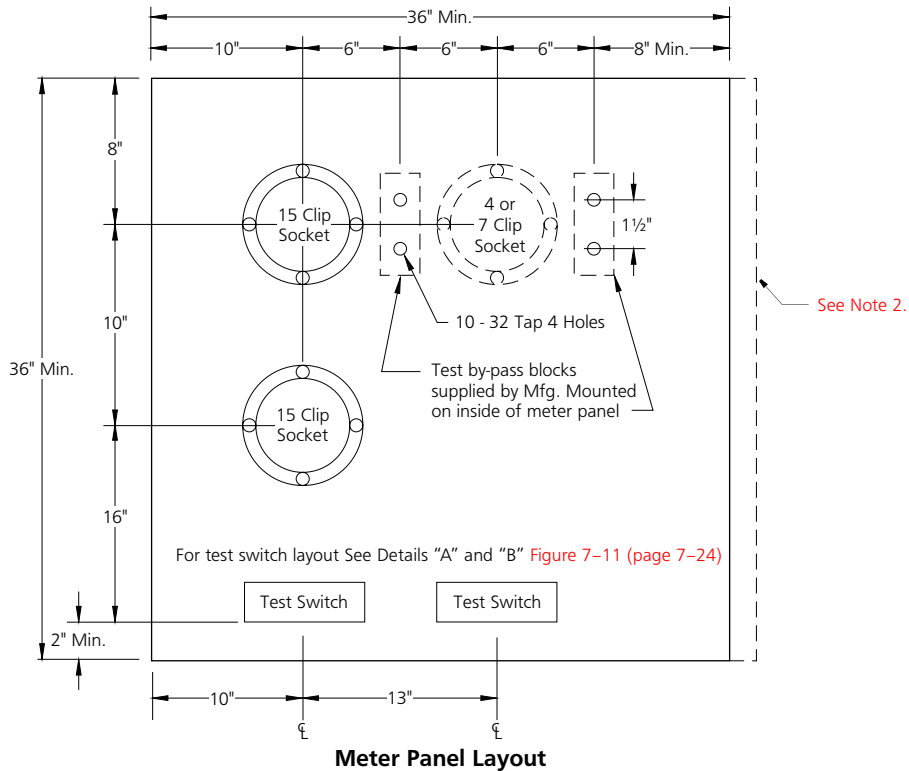

Notes:

1. Provide ring type meter sockets with clips as indicated. Screws used to mount cast meter sockets to hinged panels shall provide a 1/8 inch minimum clearance between the screw head and the back of the meter socket ring. The two 15 clip meter sockets shall be opposite the hinged door side.
2. Panel may be extended on hinged side when used with weatherproof (NEMA 3R) enclosures and three meter panel door hinges are provided.
3. Control power secondary conductors provided for metering shall be terminated by the manufacturer at test by-pass blocks and 4 or 7 clip meter socket; wired line-load sequence.
4. Conductors between test by-pass blocks and control power source shall be identified by phase and line or load.
5. Meter panel door handle to be provided opposite hinged panel side.
6. See **Control Power Meter Socket—Test Block Wiring Diagram, Figure 7-12 (page 7-24)**.

APPROVED 	Switchboards Above 600 Volts	ESR-7
EFFECTIVE DATE 1-11-2002	Electrical Service Requirements ▶ SCE Public ◀	PAGE 7-23

Figure 7-11: Test Switch Layout and Removable Plate Details

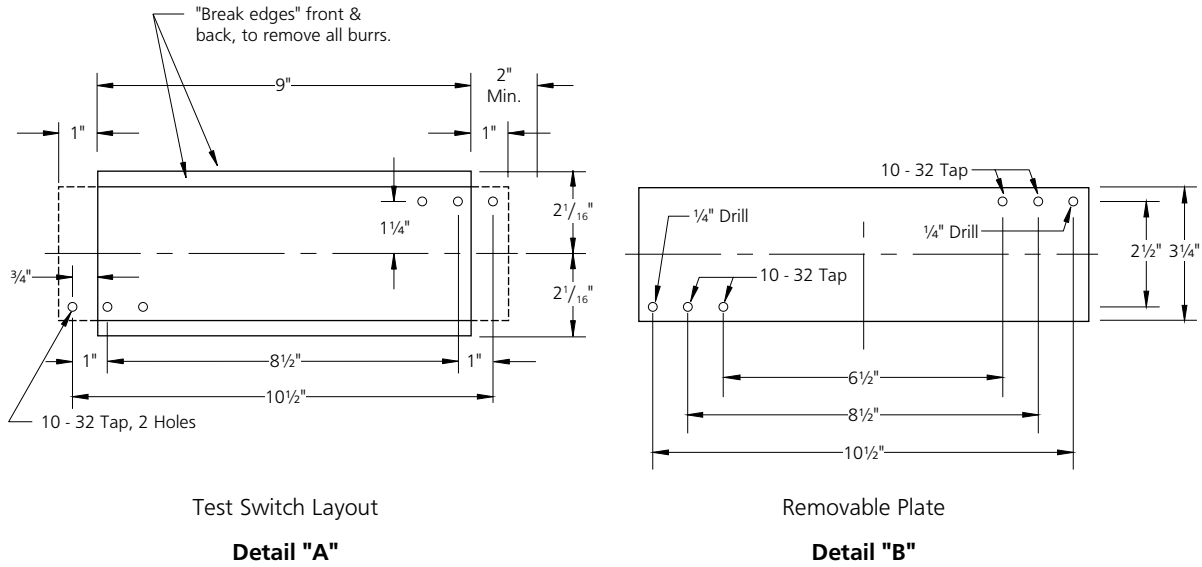
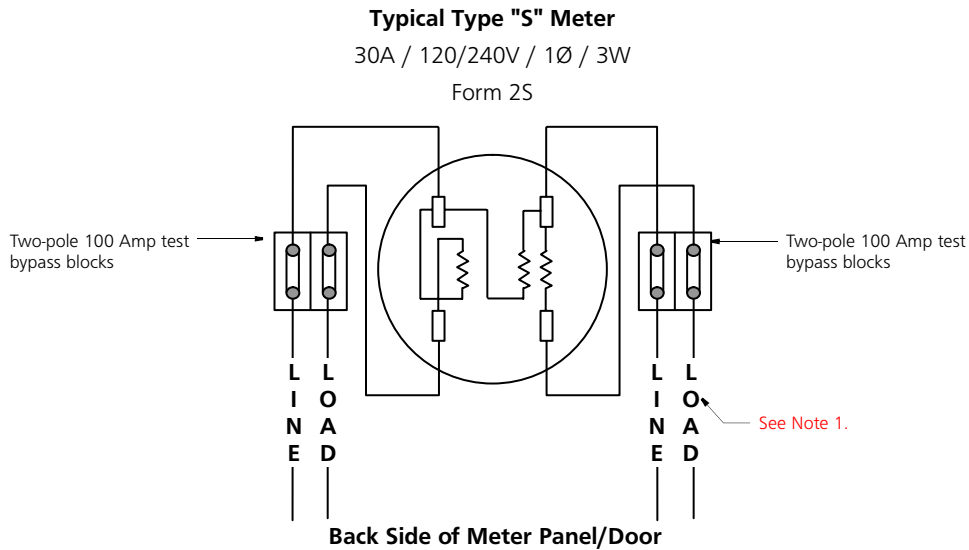

Figure 7-12: Control Power Meter Socket—Test Block Wiring Diagram



Note:

- Labels are to be provided by the manufacturer identifying LINE & LOAD. Labels shall be under each test block and placed on the back side of the meter panel/door.

ESR-7	Switchboards Above 600 Volts	APPROVED <i>PhH</i>
PAGE 7-24	Electrical Service Requirements ▶ SCE Public ◀	EFFECTIVE DATE 1-11-2002

Figure 7-13: High-Voltage Switchboards Barrier For Metering Located in Front of C.T. Area

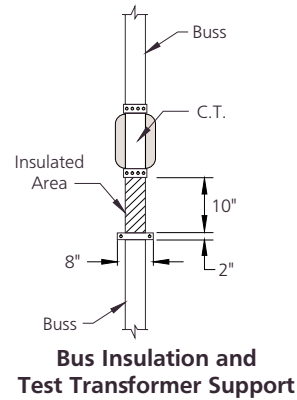
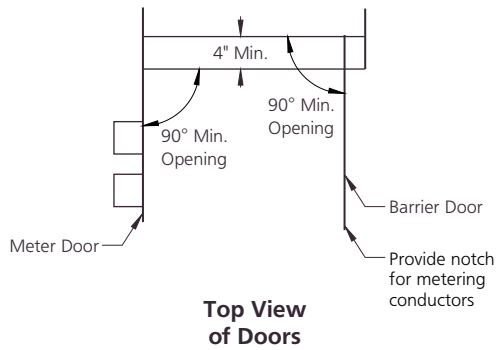

2,400 - 4,800 Volts

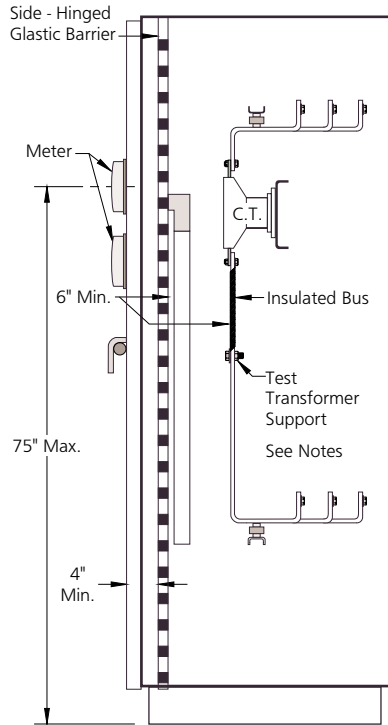

6,950 - 16,500 Volts

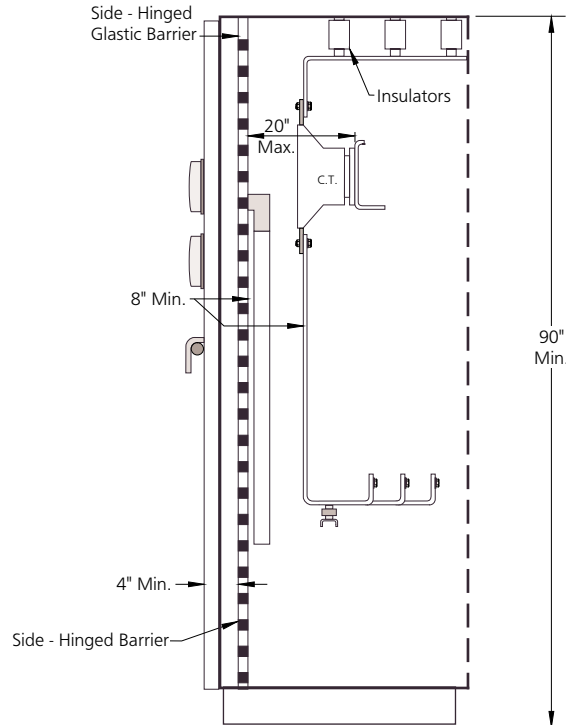

Notes:

1. Bus insulation and test transformer phenolic supports are required on switchboards 2,400-4,160 Volts.
2. Round bus corner under tapped insulated area to prevent damage to tape.
3. Equivalent insulated bus may be used in lieu of taping.
4. A 1/2" x 2" x 8" phenolic test transformer support is required on front and rear of each phase bus.

APPROVED <i>PhH</i>	Switchboards Above 600 Volts	ESR-7
EFFECTIVE DATE 1-11-2002	Electrical Service Requirements ► SCE Public ◀	PAGE 7-25

5. A 2-1/2" x 2-1/2" notch is required on the barrier door to allow metering conductors from the V.T. and C.T. areas to access meter sockets. Locate the notch on the barrier door at the hinged side of meter door, when barrier door is closed.
6. A continuous bar of equivalent insulating material and size may be installed across the compartment in lieu of individual supports.
7. Side hinged glastic barrier shall be hinged opposite side of hinged meter door.
8. Voltage Transformer conduit shall be located on hinged meter door side.
9. Provide opening slot on barrier to allow conductors to pass from voltage transformer conduit to meter door.
10. Opening handle shall be provided on barrier door.

ESR-7	Switchboards Above 600 Volts	APPROVED <i>PhH</i>
PAGE 7-26	Electrical Service Requirements ▶ SCE Public ◀	EFFECTIVE DATE 1-11-2002

ESR-8

GLOSSARY

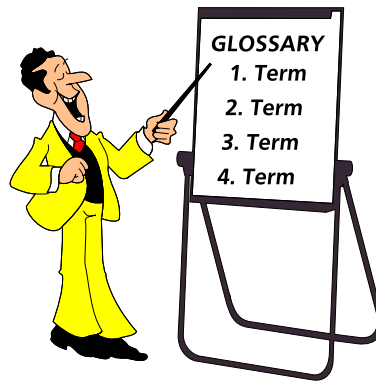

TDBU
▶ **SCE Public** ◀

 **SOUTHERN CALIFORNIA
EDISON®**
An *EDISON INTERNATIONAL* Company

**SOUTHERN CALIFORNIA EDISON
TDBU**

ESR-8: Glossary

1.0 Glossary and Abbreviations

The purpose of this section is to define and clarify the meaning of certain words and phrases concerning the use of and installation of metering and service equipment as required in this manual.^{1/}

ACCESSIBLE: A location in which all of the service equipment is installed. This shall encompass the termination section(s), metering appurtenances and all main disconnect devices. There shall be 24 hour access to this equipment as required by the Company.

ACCESS OPENING: The minimum opening of a pull or termination section or enclosure for utility work access. This opening is measured from the edge of flange to edge of flange; not from sidewall to sidewall.

ADEQUATE VENTILATION: Ventilation necessary to allow air flow, by convection, sufficient to keep the temperature of all electrical equipment (bus bars, connections, switches, circuit breakers, etc.) within an enclosure at or below the manufacturers rated temperature rise.

AGENT: One who is authorized to act for another under a contract or relation of agency, either for the Company or the customer.

ANSI: American National Standards Institute

APPROVED: Acceptable and in conformance with the Company's rules, policies and the governing codes, laws and ordinances.

AWG: American Wire Gage

BIL: Basic impulse insulation levels.

BUILDING: A structure which normally stands alone, is used for supporting or sheltering any use or occupancy.

BONDABLE: Capable of the permanent joining of metallic parts to form an electrically conductive path which will assure electrical continuity and the capacity to conduct safely any current likely to be imposed.

BREAKER: Customer's circuit breaker.

1/ When reference is made to any of the codes, standards, ordinances or requirements, it shall refer to the latest revision / edition of same.

APPROVED 	Glossary	ESR-8
EFFECTIVE DATE 9-6-2003	Electrical Service Requirements ▶ SCE Public ◀	PAGE 8-1

BUS, LIVE: Bus bars which are normally energized.

BUS, LAMINATED: More than one bus bar per phase, connected in parallel.

BUS, REMOVABLE LINK: Used in the current transformer (CT) compartment to link the line and load bus together.

BUS STUBS: The part of a bus bar reserved for the termination of conductors.

BUSWAY: A busway is considered to be a grounded metal enclosure containing factory-mounted, bare or insulated conductors, which are usually copper or aluminum bars, rods, or tubes.

CAL-OSHA: California Occupational Safety and Health Act

CAPTIVE SCREWS: Screws used to attach removable panel covers on switchboards or enclosures and designed to stay attached to the panel cover when the cover is removed.

CLEARANCE: Approval of the electrical installation by the local inspection authority having jurisdiction.

CLEARANCE, BARREL OF PROXIMITY: The clearance described by an imaginary barrel around a termination facility measured from the sides, top, bottom, front and back of the termination surface to a grounded surface or other termination facility. Includes the studs or bolts when in place.

CLEARANCE, RADIAL: The clearance required around a termination facility measured from the sides, top, and bottom of the termination surface area. See.

COGENERATION: A customer-owned generation facility that is intended to operate in parallel with the Company's distribution system for the purpose of selling excess power to the Company.

COMMERCIAL DEVELOPMENTS: Enterprises engaged in trade or furnishing services such as shopping centers, sales enterprises, business offices, professional offices, educational complexes, governmental complexes, or multi-family residential occupancies served by one meter.

COMPANY: Southern California Edison Company

CONDUCTORS, LOAD SIDE: See "CONDUCTORS, METERED" (page 8-2).

CONDUCTORS, LINE SIDE: See "CONDUCTORS, UNMETERED" (page 8-3).

CONDUCTORS, METERED: Conductors transmitting electrical energy which has been previously recorded by the Company's billing metering.

ESR-8	Glossary	APPROVED <i>PhH</i>
PAGE 8-2	Electrical Service Requirements ▶ SCE Public ◀	EFFECTIVE DATE 9-6-2003

CONDUCTORS, UNMETERED: Conductors transmitting electrical energy which has not been recorded by the Company's billing metering.

CONNECTOR, PRESSURE: A device that establishes a connection between one or more conductors and a terminal by means of mechanical pressure.

CURRENT TRANSFORMER COMPARTMENT (C.T.): See **"TRANSFORMER COMPARTMENT"** (page 8-8).

CUSTOMER: Any person, persons, corporation, etc. or their designated representative, for whom the electrical service and meter installation is provided.

ENCLOSURE: Box-like structure designed to enclose and protect Company service conductors or equipment.

EUSERC: Electric Utility Service Equipment Requirements Committee

EXO: An EXO installation is any assembled service wiring installation which does not employ a manufactured switchboard.

FILLER PANEL: The panel used on a switchboard in conjunction with a meter panel to effect a cover over an extra wide instrument transformer compartment.

FINAL GRADE: The grade after paving or improvements have been completed.

FIRST FLOOR: As defined for the purposes of this manual, is the floor that is closest to the elevation of ground level and above ground level.

HANDLES, LIFTING: Handles attached to meter and service equipment panels to aid in the panel removal/replacement, and open/close operation. They are to be designed to provide full hand grasp, secure attachment and ability to withstand the stress of a 75 pound load.

HIGH RISE BUILDING: A building with six floors or more above ground level.

HOUSE KEEPING PAD: A concrete slab used to elevate the service equipment above the ground level.

IAEI: International Association of Electrical Inspectors

IEEE: Institute of Electrical and Electronic Engineers

INDUSTRIAL DEVELOPMENTS: Enterprises engaged in a process which creates a product or changes material into form or products.

APPROVED 	Glossary	ESR-8
EFFECTIVE DATE 9-6-2003	Electrical Service Requirements ▶ SCE Public ◀	PAGE 8-3

INSPECTION AUTHORITY: These authorities include City, County, State and Federal agencies authorized to make electrical inspections; and appropriate sections of School, Port, Water and Transit Districts and other entities with legal jurisdiction over wiring on their premises. These agencies are responsible for making inspections of the customer's electrical wiring system and notifying the Company if such system meets all applicable codes/ordinances and is ready for service.

INSTRUMENT TRANSFORMER COMPARTMENT: See "TRANSFORMER COMPARTMENT" (page 8-8).

INSULATING BARRIER: A barrier of non-conductive material within an enclosure, compartment, switchboard, etc., that effectively prevents electricity from accidentally contacting a neutral, ground or phase to phase in an uncontrolled manner.

LANDING LUGS: See "LUGS" (page 8-4).

LINE WIRES: See "CONDUCTORS, UNMETERED" (page 8-3).

LUGS: Used to terminate cable conductors on termination facilities.

LUG, RANGE-TAKING: Lug designed to accept more than one size cable within a specified range.

LUG LANDING: See "BUS STUBS" (page 8-2).

METER : The equipment required, including mounting facilities, instrument transformers, protective devices and meters to measure the electric consumption and/or demand requirements of the customer.

METERED CIRCUITS: Those conductors extending from the meter and other service equipment to the loads or outlets connected to such circuits. Metered circuits are not permitted to serve one premise from another.

METER CLOSET: A small room enclosed with full length door or doors that extend from ground level to the ceiling of the enclosure. A meter closet is not a walk-in type enclosure. Sufficient clearance and depth shall be provided to allow for proper clearance for the meter. All meter closets, regardless of voltage, phase, or residential or commercial application must allow 11 inches minimum clearance measured from the face of the meter panel, to the inside of the closet door. The maximum clearance shall be 12 inches.

METER HEIGHT: Meter height is the distance measured from the center axis of the installed meter and the standing and working surface.

METER PANEL: Panel used exclusively for mounting meter sockets and associated equipment.

METER PEDESTAL: Free standing meter enclosure, typically used for residential or commercial applications. Installed by bolting to a concrete slab.

ESR-8	Glossary	APPROVED <i>PhH</i>
PAGE 8-4	Electrical Service Requirements ▶ SCE Public ◀	EFFECTIVE DATE 9-6-2003

METER POST: Free standing meter enclosure, typically used for residential mobile home service and installed by burying in the earth.

METER ROOM: A meter room is a illuminated room located inside a building provided by the customer and approved by the Company for the location of the metering and service equipment.

METER SEQUENCE: The sequential relation between the service switch and the Company's meter in a series arrangement. The term NEW SEQUENCE means a meter-switch-fuse sequence. OLD SEQUENCE means a switch-fuse-meter sequence.

METER SOCKET: Socket designed to receive socket-type meter and sealing/lock ring.

METER SOCKET, RINGLESS: Socket designed to receive socket-type meter without provision for a sealing ring.^{2/}

METER, SOCKET TYPE: Designed for use with self-contained or instrument transformer type meters to be inserted into a compatible socket.

METER TEST SWITCH: See "TEST SWITCH" (page 8-8).

MULTIPLE METERING: Prefabricated service equipment consisting of a service termination section and two or more meter sockets.

NEC: National Electrical Code (NFPA No. 70)

NECA: National Electrical Contractors Association

NEMA: National Electrical Manufacturers Association

NESC: National Electrical Safety Code

NFPA: National Fire Protection Association

NGO: Net Generation Output

NON TRACKING: Insulating material with dielectric characteristics sufficient to resist carbonizing or deterioration when subjected to rated voltage and design conditions.

PANEL, REMOVABLE: All removable access panels shall be limited to nine (9) square feet. All panels shall be provided with a lifting handle. Those panels in excess of sixteen (16) inches shall be provided with two (2) lifting handles.

PCC: Point of Common Coupling

^{2/} This type of socket is not acceptable in the SCE service territory.

APPROVED 	Glossary	ESR-8
EFFECTIVE DATE 9-6-2003	Electrical Service Requirements ▶ SCE Public ◀	PAGE 8-5

POINT OF ATTACHMENT: The point at which the Company's service drop is attached to a building or structure.

POINT OF COMMON COUPLING: Metering equipment which measures energy delivered through SCE's distribution system.

POINT OF DELIVERY: The point where the Company's facilities are connected to the premises wiring of the customer.

PREMISES IDENTIFICATION: Approved numbers or addresses to be placed for all new buildings or structures in such a position as to be plainly visible and legible from the street or road fronting the property.

PUBLIC WAY: A street, road, alley, walk or similar dedicated thoroughfare.

PULL BOX: An enclosure for joining conductors and the necessary facilities for pulling conductors into place. Included in this classification are concrete subway type pull boxes, man-holes and wall mounted pull boxes, all of which are used as terminating enclosures.

PULL CAN: A wall mounted enclosure used for pulling, routing or connecting the Company's service conductors to the customer's service equipment.

PULL SECTION: A section generally attached to the customer's switchboard where the Company's service conductors are terminated.

RACEWAY: An enclosed channel designed expressly for holding wires, cables or bus bars. If designated for line conductors, it must be sealable. The intermixing of line and load conductors in the same raceway is not permitted.

READILY ACCESSIBLE: Capable of being reached quickly and conveniently 24 hours a day for construction, operation, maintenance, inspection, testing or reading, without requiring those seeking access to climb over or remove obstacles; or to obtain keys, special permission or security clearances.

RECOGNIZED TESTING LABORATORY: An electrical component testing laboratory, nationally recognized: Example UL, ETL, CSA, etc.

RETURN FLANGE: A flange inside and around an opening. Typically used in or around pull boxes or pull section openings. The flange surface is in the plane of, and used for attachment of the cover.

SAFETY SOCKET BOX: Commercial rated self-contained meter panels, usually provided with test by-pass blocks.

SCE: Southern California Edison, *An Edison INTERNATIONAL Company.*

SEALABLE: Normally, the provision for the installation of the Company's sealing devices. Other devices such as padlocks may be specified as sealing apparatus.

ESR-8	Glossary	APPROVED <i>PhH</i>
PAGE 8-6	Electrical Service Requirements ▶ SCE Public ◀	EFFECTIVE DATE 9-6-2003

SEALING RING: Device used to hold socket-type meters in place with provisions for installing the Company's sealing device(s).

SEALING STUD ASSEMBLY: Combination of sealing stud and sealing wing-nut.

SEALING STUD: A 1/4" x 20 (minimum) stud drilled with a .0635" drill. This stud is used for sealing purposes.

SEALING WING-NUT: A 1/4" x 20 (minimum) wing nut with one wing drilled with a .0635" drill. This wing-nut is used for sealing purposes.

SERVICE: One service drop or one service lateral to a building or structure.

SERVICE DROP: The Company's overhead conductors extending from its pole line to the point of attachment on the building or structure.

SERVICE ENTRANCE CONDUCTORS - OVERHEAD: The conductors extending from the service equipment to the point of connection to the Company's service drop conductors.

SERVICE ENTRANCE CONDUCTORS - UNDERGROUND: All conductors (including bus or cable) installed by the customer beyond and including the point of connection to the Company's service lateral conductors.

SERVICE LATERAL: The underground service conductors installed by the Company from a designated source to the point of connection with the customers service entrance conductors.

SERVICE POINT: The point of connection between the facilities of the Company and the customers premises wiring.

SHALL - SHOULD - WILL AND MAY: Throughout this manual the words **SHALL** and **WILL** are used to indicate mandatory requirements of the Company or local inspection authority. The terms **SHOULD** and **MAY** are used to indicate recommendations, or that which is advised but not necessarily required.

STUB, SERVICE TERMINATION: See "TERMINAL" (page 8-8).

STUD: A threaded machine-type bolt or screw used for attachment of wire or cable connectors.

STUD, SECURED IN PLACE: A stud attached so that it will not turn, back-out, or loosen in any manner when tightening or loosening terminal nuts, including cross thread situations.

APPROVED 	Glossary	ESR-8
EFFECTIVE DATE 9-6-2003	Electrical Service Requirements ▶ SCE Public ◀	PAGE 8-7

SWITCHBOARD SERVICE SECTION: That part of the switchboard provided specifically for the termination of the Company's service conductors and instrument transformers, when required. The revenue meters, test facilities and service switch or breaker may also be located in this area. The instrument transformer compartment of this section shall be isolated from the customer's switch or breakers. That part reserved for the Company's use shall be sealable.

SWITCHBOARD, SPECIALLY ENGINEERED: A switchboard design which does not conform to the standard switchboard design and includes one or more of the following: (1) service is rated over 3,000 amperes or 600 volts; (2) where the service breaker ampacity rating exceeds that of the standard service section; (3) where multiple metering sections are used; (4) where recessed meter panels are used.

SWITCHBOARD, STANDARD: An electrical switchboard of minimum dimensions of height, width and depth with hinged meter panels and standard size instrument transformer compartment, when required.

TERMINAL: A conducting element of an equipment or circuit intended for connection to an external conductor.

TERMINATING ENCLOSURE: A Company approved type of enclosure installed at the point of service delivery for the load end termination of the Company's service cables, in which they join the customer's service entrance conductors. Included in this classification are concrete subway type pull boxes, manholes, wall mounted pull boxes and switchboard pull sections.

TERMINATING FACILITIES: Bolt-type pads, bus-stubs, or range-taking lugs provided by the customer for the sole purpose of attaching the Company's unmetred service conductors to the customer's service equipment.

TEST BY-PASS DISCONNECT FACILITIES (TEST BLOCKS): An assembly used in conjunction with a self-contained meter socket. They are designed to allow the Company to de-energize the meter socket without disconnecting service to the customer.

TEST SWITCH: An arrangement of small knife switches connected in the secondary instrument transformer circuit between the instrument transformers and associated meters and metering devices. The test switch is used by the Company to isolate the metering from the instrument transformers. Also referred to as a meter test switch.

TEST PERCH: A bracket designed for the mounting of the Company's meter test switch.

TRANSFORMER COMPARTMENT: A designated area provided within a switchboard for the Company's exclusive use to install its instrument transformers.

TRANSFORMER, INSTRUMENT: A transformer that reproduces in its secondary circuit, a definite and known proportion of the current or voltage of its primary circuit, with the phase relation substantially preserved.

ESR-8	Glossary	APPROVED <i>PhH</i>
PAGE 8-8	Electrical Service Requirements ▶ SCE Public ◀	EFFECTIVE DATE 9-6-2003

TRANSFORMER, CURRENT: An instrument transformer designed for use in the measurement of electrical current.

TRANSFORMER, VOLTAGE: An instrument transformer designed for use in the measurement of voltage.

U.L. Underwriters Laboratories, Inc.^{3/}

UTILITY METERS: Company furnished, installed, owned and maintained meters used to measure electrical consumption for billing purposes.

UTILITY'S OPERATING CONVENIENCE: This term refers to the utilization, under certain circumstances, of facilities or practices not ordinarily employed which contribute to the overall efficiency of the Company's operation.

UNDERGROUND DISTRIBUTION SYSTEM: An underground supply system employing underground structures, cables and other equipment located in a designated area on public ways or utility easements and not including service cables in the customer's service conduit.

UNDERGROUND STRUCTURE: Any conduit, subway type pull box, manhole, vault or other underground type enclosure in which cables, transformers and similar equipment are installed.

WATT HOUR METER, INSTRUMENT TRANSFORMER RATED: An electrical meter used in conjunction with instrument transformers to accurately measure and register all the electrical energy, consumed in the circuit in which it is connected. The unit of measurement is the kilowatt hour.

WATT HOUR METER, SELF-CONTAINED: An electrical meter that measures and registers all the electrical energy consumed in the circuit in which it is connected and does not require additional instrument transformers. The unit of measurement is the kilowatt hour.

WORKING SPACE: The area provided and maintained by the customer, necessary for the Company to install, remove, or maintain its conductors or equipment. This space is required in front of all devices or equipment required in providing service to the customer.

3/ The use of the term U.L. will be generic throughout this manual and will represent all reconigized testing laboratories.

APPROVED 	Glossary	ESR-8
EFFECTIVE DATE 9-6-2003	Electrical Service Requirements ▶ SCE Public ◀	PAGE 8-9

ESR-9

ALPHABETICAL INDEX



TDBU
▶ SCE Public ◀



**SOUTHERN CALIFORNIA EDISON
TDBU**

ELECTRICAL SERVICE REQUIREMENTS

ESR-9: Alphabetical Index

Numerics

Table of Contents TOC-i to TOC-vii

List of Tables TOC-viii to TOC-ix

List of Figures TOC-x to TOC-xiii

List of Approved EUSERC Drawings TOC-xiv

General Information 1-1 to 1-29

Overhead Service Connections 0-600 Volts 2-1 to 2-35

Underground Service Connections 0-600 Volts 3-1 to 3-48

Company Owned Transformers on Customer's Premises 4-1 to 4-6

Meters – EXO Installations 5-1 to 5-53

Switchboards 600 Volts and Below 6-1 to 6-33

Switchboards Above 600 Volts 7-1 to 7-26

Glossary 8-1 to 8-9

Alphabetical Index 9-1 to 9-13

A

"A" Base Meter 5-4

Access Opening - *definition* 8-1

Accessible - *definition* 8-1

Adequate Ventilation - *definition* 8-1

Agent - *definition* 8-1

Agricultural Power Service 1-18

 Motor Load, Maximum on 100 Amp Service 1-19

 Motor Load, Maximum on 200 Amp Service 1-19

Aluminum

 bodied connectors 3-25, 3-28, 3-43, 3-46

 Conductors 2-12

 Terminals 2-12

ANSI - *definition* 8-1

Approved - *definition* 8-1

AWG - *definition* 8-1

APPROVED 	Alphabetical Index	ESR-9
EFFECTIVE DATE 7-30-2004	Electrical Service Requirements ▶ SCE Public ◀	PAGE 9-1

B

Basement Ceiling Height 3–14

Bends in Conduit 3–12

Bends in Conduits 3–12, 3–23, 3–26, 3–40

BIL Rating 7–6

Bill of Sale 3–7

Bondable - *definition* 8–1

Bonding 5–33 to 5–53

Breaker

 Adequate Interrupting Capacity 2–34

definition 8–1

 Switch — See Service, Switch or Meter, Switch

Building - *definition* 8–1

Building in hazardous areas 1–27

BUS

 Approved Aluminum Plating 2–12

 Bars and Conductors, High Voltage 7–7

 Duct 2–11, 2–35, 7–20

 Laminated - *definition* 8–2

 Live - *definition* 8–2

 Removable Line - *definition* 8–2

 Stubs - *definition* 8–2

Busway 2–11, 2–35, 4–4, 4–5, 7–20

definition 8–2

 See also Service Entrance, Raceways and Bus Duct

C

C.T. See Current Transformer 8–3

CAL-OSHA - *definition* 8–2

Captive Screws - *definition* 8–2

Circuit Breaker — See Service, Switch or Meter, Switch

City/Service Planning Directory 1–6 to 1–15

Clearance

 Agricultural 2–25, 2–26

 Barrel of Proximity - *definition* 8–2

 from Customer’s yard wiring 2–9

definition 8–2

 Radial - *definition* 8–2

Cogeneration - *definition* 8–2

Commercial Developments - *definition* 8–2

Company - *definition* 8–2

Company Owned Transformers on Customers Property

 General Requirements 4–2

Conductors

 Line Side - *definition* 8–2

ESR-9	Alphabetical Index	APPROVED <i>PHH</i>
PAGE 9-2	Electrical Service Requirements ▶ SCE Public ◀	EFFECTIVE DATE 7-30-2004

Line Side See Conductors, Unmetered
Load Side
 definition 8-2
 See Conductors, Metered
Metered - *definition* 8-2
Unmetered - *definition* 8-3

Conduit
 Encasement 3-24
 Mandreling 3-12
 Material 3-25
 Service Conduit Installations 3-11
 Service Entrance for Cable in Conduit 3-38
 Size and Number of Conduits 3-11, 3-12, 3-13
 Steel 3-24, 3-25

Connector Pressure - *definition* 8-3

Current Transformer
 Compartment - *definition* 8-3
 Compartment High Voltage 7-6, 7-7, 7-8, 7-11, 7-17
 Compartment Low Voltage 5-15, 5-27, 5-30, 5-32, 5-37, 6-5, 6-9, 6-11
 See also Instrument Transformer, Compartment & Voltage Transformer for Metering

Customer
 definition 8-3
 provided transformer room or vault 4-3
 Service Voltages 1-17
 Transformation and Harmonic Interference 1-18
 Utilization Voltages 1-17

D

Definitions, See Glossary 8-1
Depth of Underground Conduit 3-11, 3-12, 3-36, 3-37, 3-38
Dig Alert 1-16

E

Easement 2-33, 3-7, 3-9, 3-24, 4-2
Electrical Service Requirements 1-3, 1-16
 Scope and Purpose 1-3
Electric-Magnetic Fields — See EMF
EMF
 Edison’s Corporate EMF Policy 1-24
 Electric Fields 1-23
 Electric-Magnetic Fields 1-23
 Magnetic Field Management Techniques 1-26
 Magnetic Field Strength Measurements 1Ø PM Transformer 1-27
 Magnetic Fields 1-24
 Magnetic Fields from Electrical Appliances 1-25
 Sources of Magnetic Fields 1-24, 1-25
Enclosure - *definition* 8-3
Energy Management Programs 1-16
EUSERC

APPROVED 	Alphabetical Index	ESR-9
EFFECTIVE DATE 7-30-2004	Electrical Service Requirements ▶ SCE Public ◀	PAGE 9-3

Cross reference of EUSERC drawings to this ESR TOC—xiv
definition 8-3

EXO - *definition* 8-3

EYS Vertical Conduit Seal Fitting and Material Application 1-28

F

Factory Built Homes 3-10

Filler Panel - *definition* 8-3

Final Grade - *definition* 8-3

First Floor - *definition* 8-3

G

Generators 1-20
definition 1-20

Ground relay 2-34

grounded neutrals through resistor 7-11

Grounding 4-6, 5-33 to 5-53
 rods 3-6, 3-23
 Under Seal 5-34

grounding under seal 5-34

Grouped Meters 1-23, 2-4, 2-5, 2-6, 2-12, 3-10, 3-19, 3-27, 5-6, 5-7, 5-18, 5-27

H

Handles, Lifting - *definition* 8-3

Harmonic Interference 1-18

Hazardous areas, flammable vapors or gases 1-27

High Rise Building - *definition* 8-3

High Voltage

 BIL Rating 7-6

 Bus Bars and Conductors 7-7

 grounded neutrals through resistor 7-11

 Metering Compartments, General 7-7

 Service and Meter Switch 7-9

 Service Connections of Switchboards 7-9

 Underground Service 7-9

 Underground Service Termination Pull Section 7-9

 Switchboard Metering Section 7-10

 Meter Panel Details 7-11

 Neutral Conductor - 4,160 Volt Service 7-11

 Utility Compartment Labeling 7-6

 Weatherproofing and Locking 7-7

High-Impedance Grounded Neutral System 5-53

House Keeping Pad 3-19
definition 8-3

ESR-9	Alphabetical Index	APPROVED <i>PhH</i>
PAGE 9-4	Electrical Service Requirements ▶ SCE Public ◀	EFFECTIVE DATE 7-30-2004

I

IAEI - *definition* 8-3

IEEE - *definition* 8-3

Industrial Developments - *definition* 8-3

Inspection Authority - *definition* 8-4

Instrument Transformer
 Compartment - *definition* 8-4
 See Current Transformer & Voltage Transformer for Metering

Insulating Barrier - *definition* 8-4

L

Labeling
 Utility Compartment 7-6

Landing Lugs
 definition 8-4
 See Lugs

Lifting Handles - *definition* 8-3

Line Wires
 definition 8-4
 See Conductors, Unmetered

Lock-Box 3-15

Lug
 Landing
 definition 8-4
 See also BUS, Stubs

 Lugs - *definition* 8-4

 Range-Taking - *definition* 8-4

M

Main Switch Rating 2-4, 2-5, 3-5, 5-14, 5-19

Meter
 "A" Base 5-4

 Access 3-15, 3-19, 5-7, 5-8, 5-11, 5-27

 Clearance 3-17, 3-18, 5-6
 High Voltage Enclosed Meter Panels 7-11

 Closet 2-17, 2-18, 5-6, 5-7, 5-8
 - *definition* 8-4

 Closet, See, Meter Room
 definition 8-4

 Enclosure 5-7

 Grounding and Bonding 5-33 to 5-53
 grounding under seal 5-34

 Gutter and Troughs 2-12

 Height 2-17, 2-18, 3-19, 3-21, 3-42, 3-46, 5-6, 5-7

 Height - *definition* 8-4

 High Voltage Panel Details 7-11

 Location 2-4, 5-7, 5-8

 Marking 3-19

 Panel

APPROVED 	Alphabetical Index	ESR-9
EFFECTIVE DATE 7-30-2004	Electrical Service Requirements ▶ SCE Public ◀	PAGE 9-5

<i>definition</i>	8-4
Switchboard	6-3, 6-4, 6-7, 6-8, 6-23, 6-28, 6-32
Pedestal	3-13, 3-45, 3-46
<i>definition</i>	8-4
See also Meter, Post	
Post	3-13, 3-36, 3-42, 3-43, 3-44
<i>definition</i>	8-5
Prohibited Location	5-10 to 5-11
Protective Barriers for Service Equipment	3-22
Reactive	7-23
Recessed	3-37
Remote	5-9
Room	5-8
Access	3-15
<i>definition</i>	3-15, 8-5
Doors	3-16
Headroom	3-17
Identification	3-19
Illumination	3-17
Lock-Box	3-15
Meter Clearances	3-17, 3-18
Meter Heights	3-19
Meter Marking	3-19
Prohibited Equipment	3-16
Vehicle Access	3-19
Working Space	3-20, 3-21
Safety socket box	5-12 to 5-14, 5-26, 5-27, 5-32
Sequence	
<i>definition</i>	8-5
High Voltage	7-9
Socket	5-4
<i>definition</i>	8-5
Marking	5-5
Ringless - <i>definition</i>	8-5
Terminal Arrangements	5-15
Type - <i>definition</i>	8-5
Socket Terminal Arrangements	5-15
Switch	1-20, 2-4, 2-5, 3-5, 5-5, 5-14, 5-19
<i>definition</i>	1-20
Equipment Permitted Ahead of	6-3, 7-10
High Voltage	7-9
Location	1-20
See also Service, Switch	
Test Switch - <i>definition</i>	8-5
Metered Circuits - <i>definition</i>	8-4
Metering	
120/204V 1Ø	5-12
120/208V 1Ø	3-5, 5-12
120/208V 3Ø	3-5, 5-12
120/240V 1Ø	3-5
120/240V 4W Delta	2-4, 3-6, 5-12, 5-21, 5-22, 5-33, 6-18, 6-19, 6-20, 6-21, 6-27, 6-28
2,400V, 4,160V, 4,800V, 7,200V, 12,000V & 16,500V	7-4 to 7-23
240/480V 1Ø	3-5
240V 1Ø	3-5
240V 3Ø	3-5, 5-12
277/480V 3Ø	3-5, 3-6, 5-12

ESR-9	Alphabetical Index	APPROVED 
PAGE 9-6	Electrical Service Requirements ▶ SCE Public ◀	EFFECTIVE DATE 7-30-2004

Concrete-Encased Electrode	5-48, 5-49
Current Transformer Compartment High Voltage	7-7, 7-8, 7-11, 7-17
Current Transformer Compartment Low Voltage	5-15, 5-27, 5-30, 5-32, 5-37, 6-5, 6-9, 6-11
EXO Installations	5-4
High Voltage Compartments, General	7-7
High Voltage Switchboard Section	7-10
High-Impedance Grounded Neutral System	5-53
Multiple Occupancy	2-4, 2-5, 2-6, 3-5, 3-10, 3-13, 3-27, 3-38, 5-7, 6-30
Protective Barrier	3-22
Reactive, Switchboards	7-23
Residential	5-11
Panel (0-400 Amps)	3-25, 3-26, 5-4, 5-12
Totalized	2-4, 2-5, 2-33, 3-5, 3-6, 5-5, 6-5
Voltage Transformer	7-6, 7-7, 7-8, 7-9, 7-10, 7-11, 7-18
Modular Homes	3-10
Motor Load; See Agricultural Power Service	
Multitape	3-12
Multiple Metering - <i>definition</i>	8-5
Multiple Occupancy Buildings	2-4, 2-5, 2-6, 3-5, 3-10, 5-7, 6-30
 N	
NEC - <i>definition</i>	8-5
NECA - <i>definition</i>	8-5
NEMA - <i>definition</i>	8-5
NESC - <i>definition</i>	8-5
Net Generation Output — See NGO	
Neutral Conductor - 4,160 Volt Service	7-11
neutrals, grounded through a resistor	7-11
NFPA - <i>definition</i>	8-5
NGO	1-20
<i>definition</i>	8-5
Non Tracking - <i>definition</i>	8-5
 O	
Office Locations — See Service Planning Office – Phone Numbers & Locations	
Outdoor Transformer Enclosures	4-4
Fenced Transformer Enclosures	4-5
Grounding	4-6
Padmounted Transformers	4-5
Service Connections	4-6
Service Equipment	4-6
Subsurface Transformers	4-6
Walled Transformer Enclosures	4-4
Over Current Protection	2-34
Overhead Service	1-19
Building or Structure	1-20
Meter Pole	1-19

APPROVED 	Alphabetical Index	ESR-9
EFFECTIVE DATE 7-30-2004	Electrical Service Requirements ▶ SCE Public ◀	PAGE 9-7

P

Padmounted Transformers 4-5

Panel

 Removable - *definition* 8-5

Periscope — See Service Drops, Periscope Support

Permits 3-7

Phone Numbers — See Service Planning Office – Phone Numbers & Locations

Point of Attachment - *definition* 8-6

Point of Common Coupling 1-21

definition 8-6

Point of Delivery - *definition* 8-6

Pole Riser, Typical 3-23

Premises Identification - *definition* 8-6

Prohibited Meter Locations 5-10 to 5-11

Protective Barriers 3-22

Public Way - *definition* 8-6

Pull Box 3-6, 3-7, 3-8, 3-9 to 3-14, 3-29, 3-30, 3-31, 3-33, 3-36, 3-41

definition 8-6

Pull Can - *definition* 8-6

Pull Rope 3-12

Pull Section 3-11, 3-13, 3-14, 3-15, 3-25, 3-26, 3-45, 3-46, 8-8

definition 8-6

R

Raceway - *definition* 8-6

Reactive Metering Switchboards 7-23

Readily Accessible - *definition* 8-6

Recessed Meters 3-37

Recognized Testing Laboratory - *definition* 8-6

Remote Meter 5-9

Residential Meter Panel (0-400 Amps) 3-25, 3-26

Return Flange - *definition* 8-6

Riser Pole, Typical 3-23

S

Safety Socket Box

definition 8-6

 with Factory-Installed Test-Bypass Facilities 5-4, 5-13, 5-20, 5-22

 Not Required 5-14

Safety socket box 5-12 to 5-14, 5-26, 5-27, 5-32

SCE - *definition* 8-6

ESR-9	Alphabetical Index	APPROVED 
PAGE 9-8	Electrical Service Requirements ▶ SCE Public ◀	EFFECTIVE DATE 7-30-2004

Scope and Purpose	1-3
Sealable - <i>definition</i>	8-6
Sealing	
Ring - <i>definition</i>	8-7
Stud	
Assembly - <i>definition</i>	8-7
<i>definition</i>	8-7
Switchboard Panels	6-9, 6-15, 6-33
Wing-Nut - <i>definition</i>	8-7
Service	2-14
0-600 Volts	3-10
Capacity	3-5
above 600 Volts	3-11
Capacity 600 Volts and Above	3-6
Agricultural	5-14
Bus Head	4-4, 4-5
Cable Replacement	1-28
Clearance from Customers's Yard Wiring	2-9
Clearance from Doors, Exits, Windows, Fire Escapes, etc.	2-20
Conductors Underground	3-8
Conduit Installations	3-11, 3-12, 3-13
Mandreling	3-12
Connections	4-6
<i>definition</i>	8-7
Delivery	3-5, 3-10
for Four Wire Delta	5-12, 5-21, 5-22, 5-33, 6-18, 6-19, 6-20, 6-21, 6-27, 6-28
for Four-Wire Delta	2-4, 3-6
Head — See Service Head	
Height	2-6, 2-7, 2-8, 2-9, 2-10, 2-11, 2-14, 2-35
High Voltage Meter Switch	7-9
Maximum Capacity of Single Phase	3-5
Maximum Capacity of Three Phase Service	3-5
Maximum Length	2-6
One Point of Attachment (Multiple Occupancy Buildings)	2-5, 2-6
to Overhead in Underground Districts	2-4, 3-5
Permits	3-7
Pole Riser, Typical	3-23
Poles, Temporary and Permanent	2-26, 2-27, 2-28, 2-29, 2-31, 2-32, 3-36
Single Point of Delivery	2-5, 2-11, 2-34, 3-10
Single-Phase — Maximum Amps 0 to 600 Volts	2-4, 3-5
Single-Phase — Maximum Amps 2,400 Volts and Above	2-33, 3-6, 4-2
Size and Number of Conduits	3-11, 3-12, 3-13
Steel Conduit	3-24, 3-25
Switch	1-20
<i>definition</i>	1-20
Location	1-20, 5-5
to Switchboards	6-3, 7-4
Three-Phase — Maximum Amps 120/208V — 240V (3 and 4W) 277/480V ..	2-5, 3-5
Three-Phase — Maximum Amps 2,400 Volts and Above	3-6, 4-2
Three-Phase 120/208V — (3 and 4W) 480V (3W) 277/480V	2-4
Three-Phase Maximum Amps 2,400 Volts and Above	2-33
Two or More Buildings	2-6, 3-10
Underground from Overhead	3-8
Underground from Underground	3-9
Underground Pole Riser	3-8
Underground Service Specifications	3-6

APPROVED 	Alphabetical Index	ESR-9
EFFECTIVE DATE 7-30-2004	Electrical Service Requirements ▶ SCE Public ◀	PAGE 9-9

Underground Termination Facilities	3-8
Un-Metered Service Pedestal, LS-2	3-47
Voltage Bandwidth	1-17
Service Connections of Switchboards, High Voltage	7-9
Service Drops	2-5, 2-6, 2-9, 2-33
Agricultural	2-25, 2-26
Attachments	2-8, 2-9, 2-14, 2-16, 2-17, 2-21, 2-23
Brick Buildings	2-8
Clearance	2-10, 2-15, 2-21
Clearance on Structures	2-23
Commercial	2-21
<i>definition</i>	8-7
High Voltage	2-33
Industrial	2-21
Location	2-10
Masonry Buildings	2-8
Maximum Length	2-6
Periscope Support	2-9, 2-18
Residential	2-8, 2-10, 2-15, 2-16
Riser	2-23
Timber Supports	2-9, 2-17
Service Entrance	2-12
Busway	2-11, 2-35, 4-4, 4-5, 7-20
Cable and Conductors	2-12, 3-8
for Cable in Conduit	3-37, 3-38
Conductors	
Overhead - <i>definition</i>	8-7
Underground - <i>definition</i>	8-7
Conductors Maximum and Minimum Length from Weatherhead	2-12
Raceways and Bus Duct	2-12, 3-30, 3-43, 4-4, 4-5
<i>definition</i>	8-6
Roof Clearance	2-14, 2-15, 2-17, 2-18, 2-22, 2-23
Separated From Load Conductors	2-12
Without Splice	2-12
Service Equipment	4-6
Service Head	2-11, 2-12, 2-13, 2-16, 2-19, 2-23, 2-29, 2-31, 2-35, 7-20
Location	2-11
Support	2-7
Service Lateral - <i>definition</i>	8-7
Service Planning Office – Phone Numbers & Locations	1-4 to 1-5
Service Point - <i>definition</i>	8-7
Service Voltage Bandwidth — See Customer, Service Voltages	
Service voltage transformed to different value by customer — See Customer, Transformation and Harmonic Interference	
Shall - <i>definition</i>	8-7
Short-Circuit Current	1-23
10,000 Amps and Below	1-23
Exceptional Cases	1-23
Greater than 10,000 Amps	1-23
Should - <i>definition</i>	8-7
Single Family Dwelling Service Entrance	3-38

ESR-9	Alphabetical Index	APPROVED 
PAGE 9-10	Electrical Service Requirements ▶ SCE Public ◀	EFFECTIVE DATE 7-30-2004

Single Point of Delivery	2-5, 2-11, 2-34, 3-10
Single-Phase Service — See Service	
stairs of normal tread and rise	5-10
Standard Distribution Voltages	1-16
Steel Conduit	3-24, 3-25
See also Conduit	
Structure Application	
Conduits—C/I Service	6-15
Stub	
See also Terminal	
Service Termination - <i>definition</i>	8-7
Stud	
<i>definition</i>	8-7
Secured in Place - <i>definition</i>	8-7
Subsurface Transformers	4-6
Swimming Pool Clearances	2-5, 2-24
Switch Rating	2-4, 2-5, 3-5, 5-14, 5-19
Switchboard	
Approvals	6-3, 7-4
compartment bus arrangement	6-16, 6-18, 6-20, 6-26
compartment bus dimensions	6-16, 6-18, 6-20, 6-25, 7-7
General Information	6-3, 7-4
High Voltage Metering Section	7-10
Locations	6-6
Mounting Pattern for Instrument Transformers 2,400V to 17000V	7-16
Outdoor	6-10, 7-5, 7-11
Pull Section	6-5, 6-9, 6-12, 6-14, 7-5, 7-9, 7-19
Self-Contained Meters	6-28
Service Section	6-3, 6-4, 6-5, 6-7, 6-8, 6-9, 6-11, 6-14, 7-4, 7-9
<i>definition</i>	8-8
Specially Engineered - <i>definition</i>	8-8
Standard - <i>definition</i>	8-8
 T	
Telephone Numbers — See Service Planning Office – Phone Numbers & Locations	
Temporary Service	1-3
Overhead	2-26, 2-27, 2-28, 2-29, 2-31, 2-32
Underground	3-7, 3-34, 3-36
Terminal - <i>definition</i>	8-8
Terminating	
Enclosure - <i>definition</i>	8-8
Facilities - <i>definition</i>	8-8
Terminating Enclosures	
Subway-Type	3-13, 3-14
Test By-Pass Disconnect Facilities (Test Blocks) - <i>definition</i>	8-8
Test Perch - <i>definition</i>	8-8
Test Switch - <i>definition</i>	8-8

APPROVED 	Alphabetical Index	ESR-9
EFFECTIVE DATE 7-30-2004	Electrical Service Requirements ▶ SCE Public ◀	PAGE 9-11

Three-Phase Service – See Service

Transformer

Compartment - *definition* 8-8
 Current - *definition* 8-9
 Instrument - *definition* 8-8
 On Customer's Premises 2-4, 3-5, 3-6, 3-8 to 3-11, 4-1, 4-2, 4-3
 Vault 2-11, 3-8 to 3-9, 4-2, 4-3, 4-4, 4-6, 5-10, 7-9
 Voltage - *definition* 8-9

Transformers on Pole Type Structures 4-2

U

U.L. - *definition* 8-9

UFER Ground 5-48, 5-49

Underground

Approved Service Conduit Material 3-25
 Basement Ceiling Height 3-14
 Bends in Conduit 3-12
 Bends in Conduits 3-12, 3-23, 3-26, 3-40
 Bill of Sale 3-7
 Conduit Mandreling 3-12
 Conduits Minimum Size and Number Required 3-11, 3-24, 3-38
 Depth of Conduit 3-11, 3-12, 3-36, 3-37, 3-38
 Distribution System - *definition* 8-9
 Easement 3-7, 3-24
 Entry of Conduit Into Building 3-13
 Entry of Conduits Into Building 3-14
 Inspection 3-6, 3-7, 3-24, 3-41
 Location of Facilities 3-8, 3-9, 3-10, 3-11
 Lug Landings in Pull Sections 3-13, 3-25, 3-28, 3-42, 3-43, 3-45, 3-46, 6-5, 6-11, 6-30
 Maximum capacity on one set of primary cables 3-6
 Maximum Length of Conduit 3-12
 Padmounted Transformers 4-5
 Permits 3-7
 Piggy Back Temporary Service Adapter 3-34
 Pole Riser, Typical 3-23
 Pull Box 3-6, 3-7, 3-8, 3-9 to 3-14, 3-29, 3-30, 3-31, 3-33, 3-36, 3-41
 definition 8-6
 Riser Bend, Approved Material 3-23
 Service Capacity 0-600 Volts 3-5
 Service Capacity 600 Volts and Above 3-6
 Service Connections 3-5
 Service Delivery 3-5, 3-10
 Service Specifications 3-6
 Steel Conduit 3-24, 3-25
 Structure - *definition* 8-9
 Subsurface Transformers 4-6
 Temporary Service Connection 3-7
 Terminating Enclosures 3-13
 Subway-Type 3-14
 Transformer Vault 2-11, 3-8 to 3-9, 4-2, 4-3, 4-4, 4-6, 5-10, 7-9
 from Underground Source 3-9

Underground Service 1-20

Building or Structure 1-20

ESR-9	Alphabetical Index	APPROVED 
PAGE 9-12	Electrical Service Requirements ▶ SCE Public ◀	EFFECTIVE DATE 7-30-2004

Conductors	3-8
Connections	3-5
Meter Pole	1-20
from Overhead Source	3-8
Pole Riser	3-8
Service Connections of High Voltage Switchboards	7-9
Temporary Power	3-34
Termination Facilities	3-8
Termination High Voltage Pull Section	7-9
from Underground Source	3-9
Un-Metered Service Pedestal, LS-2	3-47
Unusual Situation, Not covered in this manual	1-3
Utility	
Compartment Labeling	7-6
Meters - <i>definition</i>	8-9
Utility's Operating Convenience - <i>definition</i>	8-9
Utilization Voltages – See Customer, Utilization Voltages	

V

Vaults	
See Transformer, Vault and Underground, Transformer Vault	
Vaults – See Transformer, Vault and Underground, Transformer Vault	
Voltage Bandwidth	1-17
Voltage Transformer for Metering	7-6, 7-7, 7-8, 7-9, 7-10, 7-11, 7-18

W

Watt Hour Meter	
Instrument Transformer Rated - <i>definition</i>	8-9
Self-Contained - <i>definition</i>	8-9
Weatherproofing and Locking	7-7
Will and May - <i>definition</i>	8-7
Wood brace	2-30
Working Space	
<i>definition</i>	8-9
Working Space Around Meters	3-14, 3-15, 3-21, 3-22, 3-29, 3-30, 6-12, 6-13, 7-19

APPROVED 	Alphabetical Index	ESR-9
EFFECTIVE DATE 7-30-2004	Electrical Service Requirements ▶ SCE Public ◀	PAGE 9-13

